

HARTZELL PROPELLER INC.  
**ALERT SERVICE BULLETIN**

**TRANSMITTAL SHEET**

**HC-ASB-61-279**

**Propeller - Propeller Mounting Bolt Inspection**

October 4, 2005

This page transmits Revision 4 to Alert Service Bulletin HC-ASB-61-279.

- Original Issue, dated Apr 20/05
- Revision 1, dated Apr 25/05
- Revision 2, dated May 06/05
- Revision 3, dated Jun 28/05
- Revision 4, dated Oct 04/05

Propeller assemblies that have previously complied with the bolt replacement required in previous revisions of this Alert Service Bulletin are not affected.

FAA approval has been obtained on technical data in this publication that affects type design.

Changes are shown by a change bar in the left margin of the revised pages.

This revision is issued to change the following in the Service Bulletin:

- Allows compliance with HC-ASB-61-279 Rev. 4 as an Alternate Means of Compliance for FAA Airworthiness Directive 2005-14-12

HARTZELL PROPELLER INC.  
**ALERT SERVICE BULLETIN**

TRANSMITTAL SHEET

HC-ASB-61-279

(This page is intentionally blank.)

# ALERT SERVICE BULLETIN

HC-ASB-61-279

## Propeller - Propeller Mounting Bolt Inspection

### 1. Planning Information

#### A. Effectivity

- (1) Hartzell propeller models HC-B(3,4,5)( ) (P,N)-( ) ( ) that were installed on an aircraft with B-3339 mounting bolts from LFC manufacturing lot number 12 or lot 56 are affected by this Alert Service Bulletin. B-3339 mounting bolts from LFC manufacturing lot 12 and lot 56 may be found in inventory between February 13, 2004 and July 5, 2006. Refer to Figure 1.

NOTE: Propellers shipped new from Hartzell Propeller Inc. after May 6, 2005 were shipped with B-3339 bolts that are not affected by this Alert Service Bulletin.

#### B. Concurrent Requirements

- (1) Hartzell Service Bulletin HC-SB-61-256 may be applicable.

#### C. Reason

WARNING: BOLT FAILURE MAY RESULT IN SEPARATION OF THE PROPELLER FROM THE AIRCRAFT. FAILURE MAY RESULT IN DEATH, SERIOUS BODILY INJURY, AND/OR SUBSTANTIAL PROPERTY DAMAGE. UNUSUAL OR ABNORMAL VIBRATION DEMANDS IMMEDIATE INSPECTION FOR POSSIBLE BOLT FAILURE.

- (1) One propeller mounting bolt from the LFC manufacturing lot 56 yielded during the propeller installation torquing sequence.
- (2) Analysis of the affected bolt revealed that the hardness characteristics of the bolt were too low, indicating a manufacturing defect in the bolt.
- (3) Additional B-3339 propeller mounting bolts from the LFC manufacturing lot 56 were discovered to have low hardness.
- (4) The B-3339 propeller mounting bolts from the LFC manufacturing lot number 12 revealed substantial pitting.
- (5) The quantity of replacement bolts is now sufficient to support replacement of the bolts in manufacturing lot number 12 and lot number 56. Therefore, this Alert Service Bulletin has been revised to require replacement of existing inventory of the affected bolts and to prevent propeller installation with the affected bolts.
- (6) FAA Airworthiness Directive 2005-14-12 has been issued to address this Alert Service Bulletin.

# ALERT SERVICE BULLETIN

HC-ASB-61-279

## Propeller - Propeller Mounting Bolt Inspection

### D. Description

- (1) This Alert Service Bulletin provides instructions for an initial and repetitive on-wing torque inspection of all mounting bolts on propellers installed with LFC manufacturing lot 12 or lot 56 bolts.
- (2) The Alert Service Bulletin provides instruction for a terminating action to the initial and repetitive torque inspections.

### E. Compliance

- (1) Perform visual inspection and initial torque check in accordance with Paragraph 3.A. and Paragraph 3.B. in the Accomplishment section of this Alert Service Bulletin within 50 hours time-in-service (TIS) from the effective date of this Alert Service Bulletin and perform the torque inspection thereafter at intervals not to exceed 120 hours of operation from the last inspection.
- (2) Replace the LFC manufacturing lot number 12 and lot number 56 bolts with new bolts in accordance with Paragraph 3.C. of this Alert Service Bulletin before May 7, 2006. Replacement of the bolts is terminating action for the repetitive torque inspection specified in this Alert Service Bulletin.

### F. Approval

- (1) This Service Bulletin is approved by the Manager, FAA, Chicago Aircraft Certification Office, ACE 115C, by approval document dated October 4, 2005 as an alternative means of compliance with Airworthiness Directive 2005-14-12.

### G. Manpower

- (1) Approximately 1.0 man-hour per propeller assembly is required to perform the visual inspection, and the initial and repetitive torque inspection.
- (2) Approximately 1.5 man-hours per propeller assembly is required to perform the subsequent propeller mounting bolt replacement.

### H. Weight and Balance

- (1) No changed

### I. Electrical Load Data

- (1) No changed

# ALERT SERVICE BULLETIN

## HC-ASB-61-279

### Propeller - Propeller Mounting Bolt Inspection

APS0818E

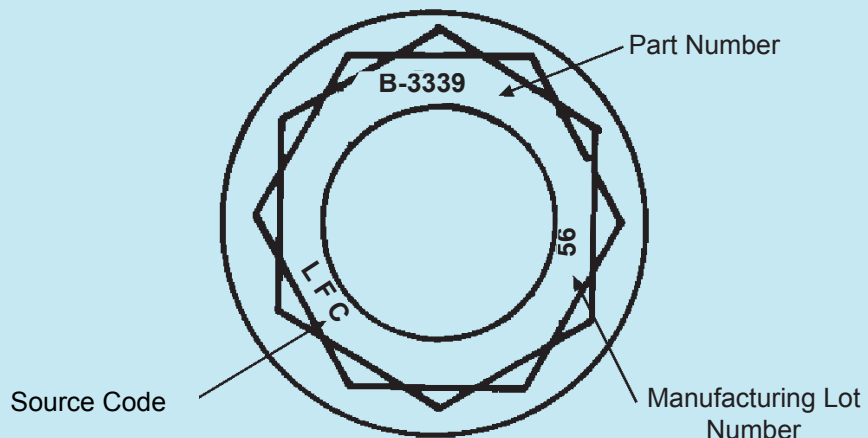
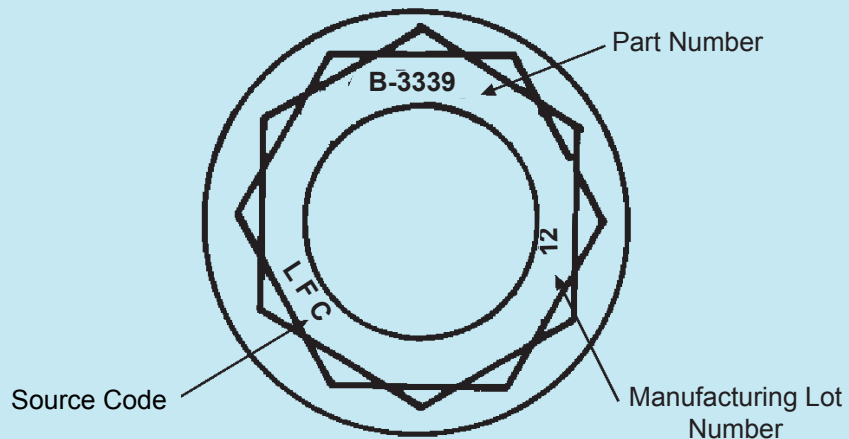

Bolt Head Identification  
Figure 1

# ALERT SERVICE BULLETIN

## HC-ASB-61-279

### Propeller - Propeller Mounting Bolt Inspection

J. References

- (1) Hartzell Propeller Owner's Manual 139 (61-00-39)
- (2) Hartzell Propeller Owner's Manual 146 (61-00-46)
- (3) Hartzell Propeller Owner's Manual 167 (61-00-67)

K. Other Publications Affected

- (1) Hartzell Steel Hub Turbine Propeller Maintenance Manual 118 (61-10-18)
- (2) Hartzell Steel Hub Turbine Propeller Maintenance Manual 132 (61-10-32)
- (3) Hartzell Propeller Owner's Manual 139 (61-00-39)
- (4) Hartzell Propeller Owner's Manual 146 (61-00-46)
- (5) Hartzell Propeller Owner's Manual 167 (61-00-67)

2. Material Information

A. Material required (if replacement of the mounting bolts is necessary)

<u>Part Number</u>	<u>Key Word</u>	<u>Qty.</u>
B-3339	Bolt	A/R

NOTE 1: Only bolts identified as the LFC manufacturing lot number 12 or lot number 56 are required to be replaced. Refer to Figure 1.

NOTE 2: A bolt that does not have any distinguishable identification markings is not a Hartzell part.

NOTE 3: This Alert Service Bulletin does not apply to mounting bolts with marking other than the marking shown in Figure 1.

# ALERT SERVICE BULLETIN

HC-ASB-61-279

## Propeller - Propeller Mounting Bolt Inspection

### 3. Accomplishment Instructions

#### A. Bolt Visual Identification

- (1) Gain access to the B-3339 propeller mounting bolts.
- (2) Visually inspect the head of each B-3339 propeller mounting bolt for identification marks. Refer to Figure 1 for the location of the identification mark.

NOTE: If the bolt heads cannot be easily accessed to allow visual inspection, perform the torque inspection before removing the bolts to allow visual inspection of bolt markings.

- (3) If a bolt from LFC manufacturing lot 12 or manufacturing lot 56 is present, perform the torque inspection in accordance with Paragraph 3.B. of this Alert Service Bulletin.
- (4) If a broken or missing bolt head is discovered, replace all eight mounting bolts regardless of lot number in accordance with Paragraph 3.C. of this Alert Service Bulletin before further flight. Contact the Hartzell Product Support Department. Refer to Paragraph 3.D. for contact information.

#### B. Mounting Bolt Torque Inspection:

- (1) Remove safety wire from mounting bolts.

CAUTION: THE NORMAL INSTALLATION TORQUE IS 100 TO 105 FT-LBS. (LUBRICATED). THIS BULLETIN REQUIRES CHECKING TO ONLY 90 FT-LBS. (IN ORDER TO AVOID POSSIBLE REPETITIVE OVER TORQUING). THE PURPOSE OF THE 90 FT-LB. CHECK IS TO VALIDATE THAT THE BOLT HAS NOT LOOSENED OR CRACKED AND ASSUMES THAT THE BOLT IS ALREADY AT 100 TO 105 FT-LBS.

- (2) Using a calibrated torque wrench and appropriate adapter, attempt to tighten each of the eight mounting bolts to 90 ft-lbs. torque.
- (3) If torque on all eight mounting bolts passes the torque inspection, make a logbook entry noting compliance with the Mounting Bolt Torque Inspection section of this Alert Service Bulletin. Perform repetitive torque inspection in accordance with the Compliance section of this Alert Service Bulletin.
- (4) Safety all mounting bolts with 0.032 inch (0.81 mm) minimum diameter stainless steel wire. (Two bolts per safety.)
- (5) If the torque of any one bolt is found to be less than 90 ft-lbs., replace all mounting bolts in accordance with Paragraph 3.C. before further flight.

# ALERT SERVICE BULLETIN

## HC-ASB-61-279

### Propeller - Propeller Mounting Bolt Inspection

C. Terminating Action

(1) On-Wing Bolt Replacement

- (a) Cut and remove the safety wire that secures each propeller mounting bolt.

CAUTION: LOOSEN ALL PROPELLER MOUNTING BOLTS TO MAKE SURE OF PROPER PRELOADING OF THE MOUNTING BOLTS WHEN THEY ARE RETORQUED.

- (b) Loosen each mounting bolt.

WARNING: DO NOT REMOVE ALL PROPELLER MOUNTING BOLTS AT THE SAME TIME WITHOUT PROPERLY SUPPORTING THE PROPELLER. SERIOUS INJURY OR DAMAGE TO THE PROPELLER COULD RESULT.

CAUTION 1: REMOVE ONE MOUNTING BOLT AT A TIME. ALL PROPELLER MOUNTING BOLTS THAT HAVE IDENTIFICATION MARKS "LFC" AND "12" OR "56" ON THE HEAD OF THE BOLT MUST BE REPLACED.

CAUTION 2: DO NOT USE EXISTING INVENTORY OF B-3339 PROPELLER MOUNTING BOLTS FROM THE LFC MANUFACTURING LOT NUMBER 12 OR 56.

- (c) Remove one mounting bolt at a time and closely inspect each bolt identification.
- 1 Replace all propeller mounting bolts that have identification marks "LFC" and manufacturing lot number "12" or "56" on the head of the bolt in accordance with the Compliance section of this Alert Service Bulletin. Refer to Figure 1.
    - a Propellers with three or more LFC manufacturing lot number 56 bolts must replace all eight mounting bolts.
    - b Propellers with LFC manufacturing lot number 12 bolts must replace the lot 12 bolts only.
- (d) Re-torque all of the propeller mounting bolts in proper sequence, in accordance with the Installation and Removal chapter of the applicable Hartzell Propeller Owner's Manual.
- (e) Safety the mounting bolts with 0.032 inch (0.81 mm) minimum diameter stainless steel wire (two bolts per safety).



HARTZELL PROPELLER INC.

# ALERT SERVICE BULLETIN

HC-ASB-61-279

## Propeller - Propeller Mounting Bolt Inspection

- (f) Indicate compliance with bolt replacement as terminating action for this Alert Service Bulletin in the propeller logbook.
- (2) Replacement of existing inventory

CAUTION: DO NOT USE EXISTING INVENTORY OF B-3339 PROPELLER MOUNTING BOLTS FROM THE LFC MANUFACTURING LOT NUMBER 12 OR 56.

- (a) Replace all existing inventory of B-3339 propeller mounting bolts from LFC manufacturing lot number 12 and lot number 56.
- (b) Refer to the Appendix of this Alert Service Bulletin for information about replacement of affected mounting bolts.

### D. Hartzell Contact Information

Hartzell Propeller Inc.  
Attn.: Product Support  
One Propeller Place  
Piqua, Ohio 45356-2634 USA  
Phone: 937.778.4379 (Intl. 001.937.778.4379)  
Fax: 937.778.4391 (Intl. 001.937.778.4391)

HARTZELL PROPELLER INC.

# ALERT SERVICE BULLETIN

HC-ASB-61-279

Propeller - Propeller Mounting Bolt Inspection

(This page is intentionally blank.)