

HARTZELL PROPELLER INC.

SERVICE BULLETIN

Propellers

Propeller - Introduction of MV Shank Propellers

1. Planning Information

A. Effectivity

All aircraft using ()H(C,A)-() (2,3)(X,V)()-() propellers with X or V shank "double shoulder" blades. Propellers are installed on, but not limited to, applications listed in Table 2.

B. Concurrent Requirements

None.

C. Reason

- (1) Existing X and V shank propellers have been subject to the repetitive inspection requirements of Hartzell Service Bulletin HC-SB-61-217 and FAA Airworthiness Directive AD 97-18-02. A design improvement to the existing V shank propellers, called MV shank or modified V shank, has been implemented in new production propellers. Hartzell has begun manufacturing an improved version of V shank propellers that are identified as "MV" propellers. The letters MV will be part of the model designation, for example HC-(A,D)(2,3)MV()-().
- (2) The MV blade shank and blade clamp is a "single shoulder" design similar to that used successfully for many years in Hartzell turbine engine propellers. MV propellers are not subject to the requirements of Hartzell Service Bulletin HC-SB-61-217 and FAA Airworthiness Directive AD 97-18-02.
- (3) This Bulletin provides model designation information, data concerning replacement/superseded part numbers, and approval basis.

D. Description

This Bulletin provides general technical information concerning approval and applicability of new ()HC-(A,D)(2,3)MV()-() as replacement propellers for ()HC-(1,8,D,A)(2,3)(X,V)()-() models.

E. Compliance

Compliance is optional.

F. Approval

FAA approval has been obtained on technical data in this publication that affects type design.

G. Manpower

No additional manpower is required for propeller replacement.

HARTZELL PROPELLER INC.

SERVICE BULLETIN

Propellers

Propeller - Introduction of MV Shank Propellers

H. Weight and Balance

When a MV shank propeller replaces a V shank propeller, weight is increased approximately two pounds for a two blade propeller and three pounds for a three blade propeller.

I. Electrical Load Data

Not changed.

J. References

Hartzell Hydro-Selective Propeller Overhaul Manual 100E (ATA # 61-10-00)
for HC-D2MV()-() series propellers,

Hartzell Steel Hub Propeller Maintenance Manual 114C (ATA # 61-10-14)
for HC-A(2,3)MV()-() series propellers,

Hartzell Steel Hub Turbine Propeller Maintenance Manual 118F, revision 5 or subs.
(ATA # 61-10-18) for HC-A3MV()-7() series Allison engine propellers,

Hartzell Standard Practices Manual 202A, revision 8 or subsequent (ATA # 61-01-02),

Hartzell Aluminum Blade Manual 133C, revision 3 or subsequent (ATA # 61-13-33).

For Hartzell service literature and revisions, contact:

Hartzell Propeller Inc.	Telephone: 937.778.4299
Technical Publications Dept.	Fax: 937.778.4365
One Propeller Place	
Piqua, Ohio 45356 U.S.A.	

2. Material Information

A. Technical Differences between V shank propellers and MV shank propellers:

NOTE: See applicable Propeller Manual 100E, Manual 114C, or Manual 118F revision 5 for detailed part number information.

- (1) The new MV shank design utilizes a single shoulder type of clamp to blade retention system, similar to that used for Hartzell turbine engine propellers, see Figure 1.
- (2) Blades - V shank blades are replaced by MV shank blades, for example V8433N is replaced by MV8433N. (However, field modification of an existing V shank to MV shank may be possible, see Service Bulletin HC-SB-61-233).
- (3) Blade Clamps - C-3-() series "double shoulder" clamps are replaced by D-6831-() "single shoulder" clamps, example: C-3-5A replaced by D-6831-5A.

HARTZELL PROPELLER INC.

SERVICE BULLETIN

Propellers

Propeller - Introduction of MV Shank Propellers

- (4) Clamp gasket - A-47-1 is replaced by A-6871-1.
- (5) Clamp and Counterweight Assemblies - C-838-() are replaced by C-838-(1000 series numbers), example: C-838-60 replaced by C-838-1060. The new part numbers differ from the previous assemblies in that they use D-6831-() Clamps and A-6871-1 Clamp Gaskets, all other components are unchanged.

B. Availability of propeller assemblies:

- (1) All future orders for V shank propellers will be changed to MV shank propellers. V shank propeller assemblies are no longer procurable from Hartzell.
- (2) Table 2 provides a listing of replacement propeller assemblies. A few models of very old, limited production designs are not procurable. If any such propellers are required, contact Hartzell Product Support Department for assistance.

NOTE: Some components of early production designs were superseded with improved parts many years ago. Models with old split ring retainer type hubs with HC-1 or HC-8... model designation have been out of production for many years and replaced with HC-D or HC-A... type hubs. X shank blades have been superseded by V shank blades for many years. For example, an early production HC-82XL-2 propeller has been superseded by model HC-A2VL-2. Now, with the additional improvement of the MV type shank design, the current propeller design that will replace a HC-82XL-2 is a HC-A2MVL-2.

C. Approval Basis:

- (1) The MV blade and propeller designs are approved under the same FAA Propeller Type Certificate as previous V shank propellers, see Table 1.
- (2) Many existing FAA Aircraft Type Certificate Data Sheets for the old aircraft affected by this Bulletin are unlikely to be revised to specifically reflect approval of the new MV type propellers. However, MV type propellers are approved for use on all applications that previously used X or V shank blades. There is a statement in the recently revised FAA Propeller Type Certificates for the ()HC-(A,D)(2,3)MV() models that says the "MV" can be substituted for propeller models with "X" or "V" in the same location.

NOTE: Similar conditions have existed for many years where V shank blades were used to replace earlier X shank blades and A or D type

HARTZELL PROPELLER INC.

SERVICE BULLETIN

Propellers

Propeller - Introduction of MV Shank Propellers

hubs were used to replace earlier 1 or 8 type hubs. Applicable FAA Propeller Type Certificates have statements like: "...V may be substituted for X..." or "...A can be substituted for 8...".

For many older propeller designs, the FAA Aircraft Type Certificate was never updated and may show, for example, a HC82XK-2 propeller even though a later HC-A2VK-2 propeller is usable and approved.

Also, note that if a FAA Aircraft Type Certificate calls for a later propeller design (like A2VK), typically there is no provision to allow use of earlier designs (like 82XK).

D. Spares support for parts used in HC-1 and 8 hubs, X and V shank propellers:

- (1) Spares support for V shank blades, C-3-() blade clamps, and related C-838-() clamp assemblies will continue to be procurable through September 30, 1999. After September 30, 1999, V shank blades and C-3-() blade clamps will no longer be procurable and:
 - (a) Orders for C-3-() series clamps or clamp assemblies will be changed to D-6831-() type clamps (thereby requiring use of MV type blades);
 - (b) Orders for C-838-() clamp/counterweight assemblies which use C-3-() type clamps will be changed to C-838-(1000 series) clamp/counterweight assemblies which use D-6831-() type clamps (thereby requiring use of MV type blades);
 - (c) Orders for V shank blades will be changed to MV type blades.
- (2) Spares support for other component parts:
 - (a) Parts for V shank propellers (other than clamps & blades) will remain procurable beyond September 30, 1999 as long as there is parts demand. This includes A-47-1 clamp gasket.
 - (b) Parts for HC-1 and 8 series propellers (other than clamps, blades & hubs) will remain procurable beyond September 30, 1999 as long as there is reasonable parts demand. This includes: blade bearings and split ring retainers which are unique to these models.
 - (c) Parts for X shank propellers - A-158L-() Pilot Tubes are no longer procurable (because propellers are to be converted from X shank to V shank). A-127-() Blade Bushings will remain procurable.

E. Pricing - pricing information for propeller assemblies and major component parts is provided in an Appendix to this Bulletin.

HARTZELL PROPELLER INC.

SERVICE BULLETIN

Propellers

Propeller - Introduction of MV Shank Propellers

2. Accomplishment Instructions

A. Installation and Maintenance of "MV" propellers:

- (1) If a MV shank propeller is used to replace an older X or V shank propeller, no additional or different installation or maintenance instructions are required, however, overhaul intervals may be different, refer to latest revision of Hartzell Service Letter 61 for details. Aside from the propeller itself, no additional or different parts are required.
- (2) Make logbook entry that shows the new propeller/blade model and serial number information. Include a statement that the propeller was installed in accordance with this Bulletin. It may be desirable to include a statement that compliance with FAA AD 97-18-02 is no longer required.

B. Overhaul, Assembly, and Disassembly Procedures and Part Number information for "MV" propellers:

- (1) Assembly, disassembly, overhaul and part number information for "MV" type propellers is found in either: Hartzell Propeller Maintenance Manual 100E, Manual 114C, or Manual 118F revision 5 depending on the specific propeller model.
- (2) Hartzell Standard Practices Manual 202A, revision 8 or subsequent, contains information concerning steel hub overhaul and blade clamp information.
- (3) Hartzell Aluminum Blade Manual 133C, revision 3 or subsequent, contains information concerning "MV" series blades. Blade airfoil repair data (minimum widths, thicknesses, etc.) for MV blades remains identical to that for existing V shank blades. Blade shank inspection and tooling for compressive rolling of blade shank is provided.

NOTE: X and V shank propeller blades have a shot peened surface in the retention area. MV blade shanks are compressive rolled instead of shot peened.

HARTZELL PROPELLER INC.

SERVICE BULLETIN

Propellers

Propeller - Introduction of MV Shank Propellers

Table 1. Propeller Type Certificates

<u>Basic Propeller Model</u>	<u>FAA Propeller Type Certificate Number</u>
HC-12X	P845
HC-D2X	P917
HC-12V	P46GL
HC-D2V, HC-D2MV	P48GL
HC-82X	P878
HC-A2X	P908
HC-82V	P23EA
HC-A2V, HC-A2MV	P24EA
HC-13X	P888
HC-D3X	P1EA
HC-D3V, HC-D3MV	P51GL
HC-83X	P884
(P)HC-A3X	P913
HC-83V	P14EA
(P,E)HC-A3V, (P,E)HC-A3MV	P6EA
HA-A2V, HA-A2MV	P59GL

NOTE: Conversion of old propeller models, such as HC-A2X() to HC-A2V(), requires changing the TC number as well as the model designation on the propeller hub. This issue is addressed in the Steel Hub Overhaul section of Hartzell Standard Practices Manual 202A.

HARTZELL PROPELLER INC.
SERVICE BULLETIN

Propellers

Propeller - Introduction of MV Shank Propellers

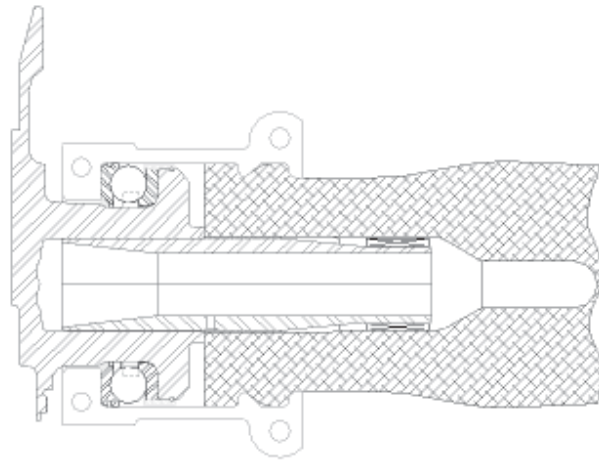

V Shank Design - "Double Shoulder" Blade with C-3-() Series Clamp

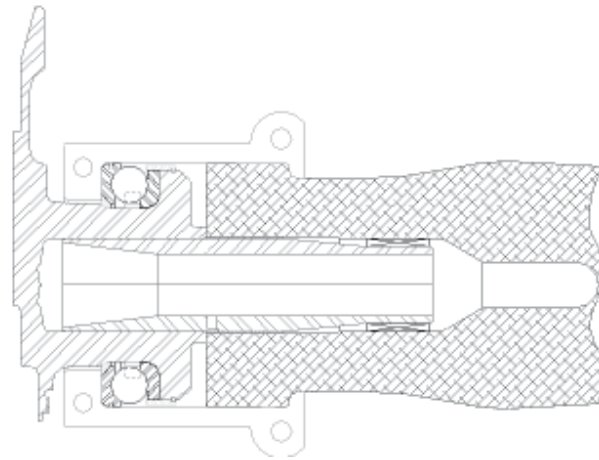

MV Shank Design - "Single Shoulder" Blade with D-6831-() Series Clamp

Figure 1. Comparison of V Shank with MV Shank Design

HARTZELL PROPELLER INC. SERVICE BULLETIN

Propellers Propeller - Introduction of MV Shank Propellers

Table 2. Aircraft and Propeller Applications

<u>AIRCRAFT MODEL</u>	<u>TC/STC #</u>	<u>ENGINE</u>	<u>OLD PROPELLER/BLADE</u>	<u>CURRENT ("MV" type) PROPELLER/BLADE</u>
AeroCommander (Twin Commander)				
500 AERO COMMANDER	STC-SA257CE	IO-540-A1A5	HC-A3VK-2/V7636D	HC-A3MVK-2B/MV7636N
500 AERO COMMANDER	STC-SA340SO	IO-520-D, -E	EHC-A3VF-2B/V7636D	EHC-A3MVF-2B/MV7636N
500 AERO COMMANDER	6A1	O-540-A2B	HC-(A,8)2(X,V)K-2/(V)84333(N)-4	HC-A2MVK-2/MV84333N-4
500 AERO COMMANDER	UNK	O-540-A2B	HC-A3VK-2B/V7636D	HC-A3MVK-2B/MV7636N
500A AERO COMMANDER	6A1	IO-470-M	HC-A2(X,V)F-2/(V)84333(N)-4	HC-A2MVF-2/MV84333N-4
500B, 500S, 500U AERO COMM.	EXP	IO-540-	HC-A3VK-2B/V8433N-6Q	HC-A3MVK-2A/MV8433N-6Q
500B, 500U, 500S AERO COMM.	6A1	IO-540-B1(A,C)5, E1(A,B)5	HC-A3(X,V)K-2, -2A/(V)8433(N)-4	HC-A3MVK-2A/MV8433N-4
500U, 500S AERO COMM.	STC-SA2478SW	IO-720-B1B, -B1BD	HC-A3VK-2A/V8433(N)-4R, -4Q	HC-A3MVK-2A/MV8433N-4R, -4Q
520 AERO COMMANDER	6A1	GO-435-C2	HC-12X20-8C, 9C/9333C-3	not procurable
520 AERO COMMANDER	6A1	GO-435-C2, -C2B, -C2B1	HC-82X20-2/9333C-3	HC-A2MV20-2/MV9333N-3
520 AERO COMMANDER	6A1	GO-435-C2, -C2B, -C2B1	HC-83X20-2/8433	HC-A3MV20-2/MV8433N
560 AERO COMMANDER	STC-SA2-89	GO-480-C1D6	HC-83X20-2/V8833(N)(-2), V8433(N)	HC-A3MV20-2/MV8833N(-2)
560 AERO COMMANDER	6A1	GO-480-B, -B1C	HC-82X20-2/9333C-3	HC-A2MV20-2/MV9333N-3
560A AERO COMMANDER	6A1	GO-480-D1A, -(C,G)1B6	HC-83X20-2/8433	HC-A3MV20-2/MV8433N
560A, 560E AERO COMM.	6A1	GO-480-(C,G)1B6	HC-83X20-2/(V)8833(N)-2	HC-A3MV20-2/MV8833N-2
680, 680E AERO COMMANDER	STC-SA439WE	IGSO-480-A1D6	HC-A3X20-2/9333C	HC-A3MV20-2/MV9333N
680, 680E, 720 AERO COMM.	2A4	GSO-480-A1A6, -B1A6	HC-83X20-2/9333C	HC-A3MV20-2/MV9333N
680F AERO COMMANDER	UNK	IO-720-B1B	HC-A3VK-2A/V8433B-6Q	HC-A3MVK-2A/MV8433NB-6Q
680F, FP, FL, FLR AERO COMM.	STC-SA2891WE	IO-720-B1B	HC-A3VK-2A/V8433-R	HC-A3MVK-2A/MV8433N
B1 (CALLAIR)	A7WE, A8WE	IO-720-A1A	HC-A3VK-4/V8433(N)-4	HC-A3MVK-4/MV8433N-4
Aeromere				
FALCO F.8.L	7A11	O-320-A1A	HC-82XL-1F/7636D-4	HC-A2MVL-1/MV7636N-4
Aeronautica Macchi				
AL60-F5	7A12	IO-720-A1A	HC-A3VK-4/V8433	HC-A3MVK-4/MV8433N
AM-3	A19EU	GTSIO-520-C	HC-A3VF-4/V8833	HC-A3MVK-4/MV8433N
Bauger				
SAIL PLANE	UNK	O-290-D	HC-A2XL-2/7636D-4	HC-A2MVL-2/MV7636N-4
Beech				
35 SERIES BONANZA	STC-SA4-1305		HC-12X20-7E/8433	HC-D2MV20-7/MV8433N
35 SERIES BONANZA	STC-SA4-550	E-225-8	HC-12X20/8433	HC-D2MV20-7/MV8433N
35 SERIES BONANZA	STC-SA4-785		HC-12X20-7D/(V)8433(N)	HC-D2MV20-7/MV8433N
35 SERIES BONANZA	STC-SA4-819		HC-12X20-7D/(V)8433(N)	HC-D2MV20-7/MV8433N
35 SERIES BONANZA	STC-SA609SW		PHC-A3VF-4/V8433-4, V8433N-4	PHC-A3MVF-4/MV8433N-4
35 SERIES BONANZA	STC-SA4-1146		HC-12X20-7C/(V)8433(N)	HC-D2MV20-7/MV8433N
35, A35 BONANZA	A777	E-185-1	HC-12X20-7B/8433	HC-D2MV20-7/MV8433N
35, A35, B35 BONANZA	A777	E-185-1, E-185-8	HC-12X20-7C/8433	HC-D2MV20-7/MV8433N
35, A35, B35, C35, D35, E35, F35	STC-SA1-570	E-185-8, -11, -1; E225-8	HC-A2X20-4A1/(V)8433(N)(-4)	HC-A2MV20-4A1/MV8433N(-4)
C35, D35 BONANZA	A777	GO-435-D1	HC-12X20-1/(V)9333C-3	not procurable
G35, 35R BONANZA	STC-SA1-570	E-225-8	HC-A2X20-4A1/(V)8433(N)(-4)	HC-A2MV20-4A1/MV8433N(-4)
S35, V35 BONANZA	3A15	IO-520-; TSIO-520-D	PHC-A3VF-4/8433-2R, -4R	PHC-A3MVF-4/MV8433N-2R, -4R
V35A, V35B BONANZA	3A15	IO-520-; TSIO-520-D	PHC-A3VF-4/8433-4R	PHC-A3MVF-4/MV8433N-4R
35-C33 DEBONAIR	3A15	IO-470-K	PHC-A3VF-4/V8433-4R(D)	PHC-A3MVF-4/MV8433N-4R(D)
35-C33A, E33A, F33A	3A15	IO-520-B, -BA, -BB	PHC-A3VF-4/8433-2R, -4R	PHC-A3MVF-4/MV8433N-2R, -4R

Mar 20/98

HC-SB-61-232
Page 8 of 13

HARTZELL PROPELLER INC. SERVICE BULLETIN

Propellers Propeller - Introduction of MV Shank Propellers

Table 2. Aircraft and Propeller Applications

Mar 20/98

<u>AIRCRAFT MODEL</u>	<u>TC/STC #</u>	<u>ENGINE</u>	<u>OLD PROPELLER/BLADE</u>	<u>CURRENT ("MV" type) PROPELLER/BLADE</u>
50 SERIES TWIN BONANZA	STC-SA2-665	GO-480-C3C6, -C2D6	HC-83XF-2A/9333C-3	HC-A3MVF-2A/MV9333N-3
50 SERIES TWIN BONANZA	STC-SA2-87,93	GO-480-C2C6, -C2D6	HC-83X20-2E/9333C-3	HC-A3MV20-2/MV9333N-3
50 SERIES TWIN BONANZA	STC-SA2-602	GO-480-F4B6	HC-83XF-2A/9333C-3	HC-A3MVF-2A/MV9333N-3
50 SERIES TWIN BONANZA	STC-SA2-602	GO-480-F2A6	HC-83X20-2C/9333C-3	HC-A3MV20-2/MV9333N-3
50 SERIES TWIN BONANZA	STC-SA2-1	GO-435-C2B	HC-83X20-2C/9333C-3	HC-A3MV20-2/MV9333N-3
50, B50, C50 TWIN BONANZA	STC-SA2-66	GO-480-B,-B1(B,C,D), -F2A	HC-83X20-2C/9333C-3	HC-A3MV20-2/MV9333N-3
58P, 58TC BARON	STC-SA538GL	TSIO-520-L, -LB, -WB	PHC-A3VF-5R/V7636NRB	PHC-A3MVF-5R/MV7636NRB
BARON	STC-SA350SO	IO-520-E	EHC-A3VF-2B/V7636D(B)-2R	EHC-A3MVF-2B/MV7636N(B)-2R
95-55, 95-A55, 95-B55 BARON	STC-SA126CE	IO-470	(P)HC-A3(X,V)F-2B(V)7636D, V7636N	(P)HC-A3MVF-2B/MV7636N
65, A65, 65-(B)80, 65-A80, 70	STC-SA444SW	IO-720-A1A, -A1B	HC-A3VK-2A/V8433-2R, -4R, -4Q	HC-A3MVK-2A/MV8433N-2R,-4(R,Q)
65, A65, A65-8200, 70	STC-SA2365WE		HC-83X20-2/9333C-3	HC-A3MV20-2/MV9333N-3
B50 TWIN BONANZA	5A4	GO-435-C2B	HC-83X20-2C/9333C-3	HC-A3MV20-2/MV9333N-3
C50 TWIN BONANZA	STC-SA2-233	GO-480-F4B6, -F4A6	HC-83XF-2A, -A3VF-2/9333C-3	HC-A3MVF-2A/MV9333N-3
C50 (EXCALIBER)	STC-SA360/242SW	GO-480-G2D6, -G2F6	HC-A3VF-2/V9333C-3 TO -4	HC-A3MVF-2/MV9333N-3
D50, D50A, D50B, D50C, D50E	5A4	GO-480-(C,G)2(C,D,F)6	HC-(A,8)3(X,V)F-2A/9333C-3	HC-A3MVF-2A/MV9333N-3
Bellanca				
14-13	STC-SA2-848	O-435-C	HC-12X20-8D, -D2X20-8/8433-6	HC-D2MV20-8/MV8433N-6
14-19	1A3	O-435-A	HC-12X20-8C, -D2X20-8/8433-6	HC-D2MV20-8/MV8433N-6
14-19-2	1A3	O-470-K	HC-82XF-1, -A2XF-1A/8433S-6	HC-A2MVF-1A/MV8433NS-6
14-19-3	1A3	IO-470-F	HC-A2XF-1A/8433-2	HC-A2MVF-1A/MV8433N-2
7GCA, 7GCB, 7GCC	STC-SA282AL		HC-82XL-1/7636D-4	HC-A2MVL-1/MV7636N-4
DW-1 EAGLE	A4NW	W670-6N,-6A (R-670-4,-5)	HA-A2V20-1B/V10133N	HA-A2MV20-1B/MV10133N
Camair				
480	2A2	O-470-B	HC-82XF-2B/8433-2	HC-A2MVF-2B/MV8433N-2
480	2A2	O-470-D	HC-82XF-2B/8433-4	HC-A2MVF-2B/MV8433N-4
Cessna				
170	STC-SA1-245	O-340-A1A	HC-82XL-1F, -A2XL-1/8433-12	HC-A2MVL-1/MV8433N-12
170	STC-SA135CE	O-320-(A,B)(1,3)(A,B)	HC-82XL-1F, -A2XL-1/7636D-4	HC-A2MVL-1/MV7636N-4
170	STC-SA3-13	O-340	HC-82XL-1F, -A2XL-1/7636D-4	HC-A2MVL-1/MV7636N-4
170A	STC-SA1-240	O-435-C	HC-(1,D)2X20-8(D), -5C/8433-6	HC-D2MV20-8/MV8433N-6
172 SKYHAWK	STC-SA3-126	O-340-A1A	HC-82XL-1F/8433-12	HC-A2MVL-1/MV8433N-12
172, 175	STC-SA610SW	O-320	HC-82XL-2/7636D-4	not procurable
180, A, B, C, D, E, F, G, H	STC-SA816SW	O-470-A, -J, -R, -K, -L	BHC-A2VF-3/V8833	BHC-A2MVF-3/MV8833N
180,A,B,C,D,E,F	5A6	O-470-A,-J, -K,-L	(B)HC-(8,A)2(X,V)F-(1,6)/8833	(B)HC-A2MVF-1A/MV8833N
182	STC-SA108CE		BHC-A2VF-3/V8433-2	BHC-A2MVF-3/MV8433N-2
182, 182A, B, C, D, E	STC-SA129EA	O-470-L	(B)HC-A2XF-G or -1/8433-2	BHC-A2MVF-1A/MV8433N-2
182, A, B, C, D, E, F, G	3A13	O-470-L, -R	(B)HC-(8,A)2(X,V)F-1/8433-2	BHC-A2MVF-1A/MV8433N-2
182E, F, G, H, J, K, L, M	STC-SA692SW		BHC-A2VF-3/8433-2	BHC-A2MVF-3/MV8433N-2
210, A, B, C, 5, 5A	3A21	IO-470-E, -S	HC-A2XF-1/8433-2	HC-A2MVF-1A/MV8433N-2
310	UNK	IO-540-(A,B)1(A,B)5	HC-A3(V,X)K-2B/V7636DB	HC-A3MVK-2B/MV7636NB
310, 310A, 310B	3A10	O-470-B, -M	HC-(A,8)2(X,V)F-2/8433	HC-A2MVF-2/MV8433N
310, 310B, 310G	STC-SA212SO	IO-540-A1A5	HC-A3(X,V)K-2B(V)7636D(B)	HC-A3MVK-2B/MV7636N(B)
310C, D, E, F, G, H, E310H	3A10	IO-470-D	HC-(A,8)2(X,V)F-2B/8433	HC-A2MVF-2/MV8433N
320, 320-1 SKYKNIGHT	STC-SA285SO	IO-540-A1A5	HC-A3XK-2B/7636D	HC-A3MVK-2B/MV7636N
320, 320-1, 320A, 320B	3A25	TSIO-470-B, -C	HC-A2XF-2/8433-4	HC-A2MVF-2/MV8433N-4

HARTZELL PROPELLER INC. SERVICE BULLETIN

Propellers

Propeller - Introduction of MV Shank Propellers

Table 2. Aircraft and Propeller Applications

<u>AIRCRAFT MODEL</u>	<u>TC/STC #</u>	<u>ENGINE</u>	<u>OLD PROPELLER/BLADE</u>	<u>CURRENT ("MV" type) PROPELLER/BLADE</u>
402 BUSINESSLINER	UNK	250-C18	HC-A3VF-7/V9333C-3R	HC-A3MVF-7/MV9333N-3R
411	A7CE	GTSIO-520-C	HC-A3VF-2D/V8833	HC-A3MVF-2D/MV8833N
WREN 460	STC-SA403SW		BHC-A2VF-3/V8433-2	BHC-A2MVF-3/MV8433N-2
WREN 460H, J, K, L, M	STC-SA485SW		BHC-A2VF-3/V8433-2	BHC-A2MVF-3/MV8433N-2
DeHavilland				
DH104 DOVE	STC-SA168SO	IO-720-A1A	HC-A3VK-2A/V8433-4R	HC-A3MVK-2A/MV8433N-4R
DH114 HERON	STC-SA629SO	IO-540-G1B5	HC-A3VK-2A/V8433-7	HC-A3MVK-2A/MV8433N-7
DH114 HERON	STC-SA816WE	GYPSY QUEEN 30MK-2	HC-A3X21-2L/L7636D TO -1	not procurable
Dornier				
DO27Q-6	A8IN	GO-480-B1A6	HC-82X20-1B, -A2X20-1/10133D-3	HC-A2MV20-1A/MV10133N-3
DO28A-1	7A13	O-540-A1D	HC-A2XK-2/8433-2	HC-A2MVK-2/MV8433N-2
DO28B-1	7A13	IO-540-A1A5	HC-A3VK-2C/V8433-4	HC-A3MVK-2C/MV8433N-4
Fuji				
T-3, LM-2	UNK	IGSO-480-A1F6	HC-A3V20-1F/V9333N-3	HC-A3MV20-1F/MV9333N-3
GAF - Gov't. Aircraft Factories				
N22B, N24A, N22S, N22C	A7PC	250-B17B, -B17C,E,F	HC-A3VF-7, -7B/V10133(D,N)-11	HC-A3MVF-7B/MV10133N-11
Goodyear (Loral)				
GA22A GOODYEAR BLIMP	1A12	E-225-8	HC-12X20-5E/L8833	not procurable
GZ19, 19A GOODYEAR BLIMP	1	GO-300-F	HC-82XF-3L/L9333CH-3	not procurable
Great Lakes				
2T-1A-2	EXP	250-B17C	HC-A3VF-7/V10133AN-11	HC-A3MVF-7/MV10133AN-11
Grumman				
G44, G44A WIDGEON	A734	GO-435-C2, -C2B	HC-12X20-9/9333C	not procurable
G44, G44A WIDGEON	A734	GO-435-C2, -C2B	HC-82X20-2/9333C-3	HC-A2MV20-2/MV9333N-3
G44, G44A WIDGEON	A734	GO-435-C2B	HC-82X20-2/9333C-3	HC-A2MV20-2/MV9333N-3
G44, G44A WIDGEON	A734	GO-435-C2B	HC-83X20-2A/8433	HC-A3MV20-2/MV8433N
G44, G44A WIDGEON	STC-	IO-520-E	PHC-A3VF-2B/V7636N	PHC-A3MVF-2B/MV7636N
G44, G44A WIDGEON	STC-	6-440-C5	HC-D2X20-8/8833	HC-D2MV20-8/MV8833N
G44, G44A WIDGEON	STC-SA2-13	IO-470-D	HC-82XF-2B/8433	HC-A2MVF-2B/MV8433N
G44, G44A WIDGEON	STC-SA4-65,-64	GO-480-B1	HC-83X20-2A/8433	HC-A3MV20-2/MV8433N
G44, G44A WIDGEON	STC-SA4-64	GO-435-C2B	HC-83X20-2A/8433	HC-A3MV20-2/MV8433N
G44, G44A WIDGEON	STC-SA4-64	GO-435-C2B	HC-82X20-2/9333C-3	HC-A2MV20-2/MV9333N-3
G44, G44A WIDGEON	STC-SA4-111	GO-480-C1D6	HC-83X20-2A/8433	HC-A3MV20-2/MV8433N
G44, G44A WIDGEON	STC-SA835SO	GO-480-G2D6	HC-A3VF-5R/V9333C(H)-3	HC-A3MVF-5R/MV9333N-3
G44, G44A WIDGEON	STC-	6-440-C5	HC-A2V20-2/V8833NS	HC-A2MV20-2/MV8833NS
G44, G44A WIDGEON	A734	GO-480-B1	HC-83X20-2A/8433	HC-A3MV20-2/MV8433N
G44, G44A WIDGEON	STC-SA2-13	O-470-B	HC-82XF-2C/8433	HC-A2MVF-2/MV8433N
G21C, D GOOSE	4A24	GSO-480-B2D6	HC-83XF-3A/9333CH	not procurable
Helio				
H-391 COURIER	1A8	GO-435-C2	HC-12X20-8C/9333C	HC-D2MV20-8/MV9333N
H-391B COURIER	1A8	GO-435-C2B()	HC-82X20-1A, -1B/10133D	HC-A2MV20-1A/MV10133N
H-395A COURIER	1A8	GO-435-C2B2-6	HC-(8,A)2X20-1A, -1B/10133D	HC-A2MV20-1A/MV10133N

Mar 20/98

HC-SB-61-232
Page 10 of 13

HARTZELL PROPELLER INC. SERVICE BULLETIN

Propellers Propeller - Introduction of MV Shank Propellers

Table 2. Aircraft and Propeller Applications

Mar 20/98

<u>AIRCRAFT MODEL</u>	<u>TC/STC #</u>	<u>ENGINE</u>	<u>OLD PROPELLER/BLADE</u>	<u>CURRENT ("MV" type) PROPELLER/BLADE</u>
Luscombe				
11	STC-SA3-71	E-185-2	HC-A2XF-2/8433-1	HC-A2MVF-2/MV8433N-1
11A	A-804	E-185-2	HC-42XF-2/8433-1	not procurable
Mooney				
M20	2A3	O-320	HC-82XG-1B, -A2XL-1/7636D	HC-A2MVL-1/MV7636N
Multitech (Temco)				
D16 TWIN NAVION	2A1	O-320-A1A	HC-82XG-2,-A2XL-2/7636C-2, D-2	HC-A2MVL-2/MV7636N-2
D16 TWIN NAVION	2A1	O-290-D2A	HC-82XG-2,-A2XL-2/7636C-2	HC-A2MVL-2/MV7636N-2
D16A, D16 TWIN NAVION	2A1	O-340-A1A	HC-82XG-2,-A2XL-2/8433-12	HC-A2MVL-2/MV8433N-12
Nardi				
FN-333	7A5	IO-470-P	HC-A3X20-5L/L8433-6B	not procurable
FN-333	7A5	IO-470-P	HC-(A,8)2X20-5L/L8433H	not procurable
Navion				
NAVION	A782	E-185-3	HC-52X20-1/8433	not procurable
NAVION	STC-SA1-635	E-185-()	HC-A2X20-4A1/8433	HC-A2MV20-4A1/MV8433N
NAVION	STC-SA1-635	E-225-4	HC-A2X20-4A1/8433	HC-A2MV20-4A1/MV8433N
NAVION	STC-SA4-118		HC-12X20-7C/8433-0	HC-D2MV20-7/MV8433N
NAVION B	STC-SA752WE	GO-480-B1D	HC-83X207/9333C-3	not procurable
NAVION B	A782	GO-435-C2	HC-12X20-8C/9333C	HC-D2MV20-8/MV9333N
NAVION B	A782	GO-435-C2	HC-13X20-8D/8433	not procurable
NAVION, NAVION A	A782	E-225-4	HC-12X20-7B/8433	HC-D2MV20-7/MV8433N
NAVION, NAVION A	A782	E-185-3, -9	HC-12X20-7() , -8()/8433	HC-D2MV20-(7,8)/MV8433N
NAVION, NAVION A	A782	E-185-3, -9	HC-12X20-5/8433	not procurable
NAVION, NAVION A	A782	E-185-3, -9	HC-12X20-1/8433	not procurable
Pacific Aerospace (Fletcher)				
FU-24, FU-24A	4A12	O-470-E	HC-82XF-1B/8833	HC-A2MVF-1A/MV8833N
Piaggio				
P-149D	UNK	GO-480-B1A6	HC-A3V20-1D/V8433N	HC-A3MV20-1D/MV8433N
P136-L1 ROYAL GULL	A813	GO-480-B, -B1B, -B1D	HC-83X20-2CL/L8433	HC-A3MV20-2L/LMV8433N
P136-L2 ROYAL GULL	A813	GSO-480-A1A6	HC-83X20-2CL/L9333C	HC-A3MV20-2L/LMV9333N
P149D	UNK	GO-480-G(), IGO-480-A1B6	HC-A3V20-1()/V9333C, V9333N	HC-A3MV20-1F/MV9333N
P166 ROYAL GULL	7A4	GSO-480-B1C6	HC-(A,8)3X20-2CL/L9333C(H)	HC-A3MV20-2L/LMV9333N
P166 ROYAL GULL	UNK	GSO-480	HC-A3VF-5AL/VL9333CH-5	HC-A3MVF-5AL/LMV9333N-5
Pilatus				
PC-3	UNK	GO-435-C2A	HC-83X20-2A/8433	HC-A3MV20-2/MV8433N
PC-6; PC-6-H1, -H2 PORTER	7A15	GSO-480-B1A6	HC-A3X20-1D, -83X20-1B/9333C	HC-A3MV20-1D, -1B/MV9333N
Piper				
PA-E23-250 AZTEC	STC-SA164CE	O-540-A1B5, -A3D5, -A1D5	HC-A3XK-2B/7636D-4	HC-A3MVK-2B/MV7636N-4
PA14 FAMILY CRUISER	STC-SA196SW	O-235-C1	HC-82XL-6F/7636D-4	HC-A2MVL-6F/MV7636N-4
PA18(A)(S)-150 SUPER CUB	STC-SA4-1143	O-320-A3B	HC-82XL-6F/7636D-2	HC-A2MVL-6F/MV7636N-2
PA18(A)(S)-150 SUPER CUB	STC-SA284AL	O-320-A2A, -A2A	HC-82XL-1,-2,-6/7636D-4	HC-A2MVL-1,-6F/MV7636N-4
PA18A-150 SUPER CUB	STC-SA4-254	O-320-A2A, -A2B	HC-82XL-6F/7636D-4	HC-A2MVL-6F/MV7636N-4
PA22-150, PA22S-150 TRIPACER	1A6	O-320-A1A, -A1B	HC-82XL-6F/7636D-4	HC-A2MVL-6F/MV7636N-4
PA23	STC-SA179CE	IO-540-A1A5	HC-A3XK-2C/8433-10 TO -12	HC-A3MVK-2C/MV8433N-10 to -12
PA23	STC-SA179CE	IO-540-G1A5	HC-A3XK-2B/7636D-4	HC-A3MVK-2B/MV7636N-4

HARTZELL PROPELLER INC. SERVICE BULLETIN

Propellers Introduction of MV Shank Propellers

Table 2. Aircraft and Propeller Applications

<u>AIRCRAFT MODEL</u>	<u>TC/STC #</u>	<u>ENGINE</u>	<u>OLD PROPELLER/BLADE</u>	<u>CURRENT ("MV" type) PROPELLER/BLADE</u>
PA23 APACHE	1A10	O-320-A(1,3)(A,B)	HC-82XG-2/7636D	HC-A2MVL-2/MV7636N
PA23 APACHE	1A10	O-320-A(1,3)(A,B)	HC-(8,A)2X(G,L)-2()/7636D-4	HC-A2MVL-2/MV7636N-4
PA23 APACHE	STC-SA4-783	O-340-A1A	HC-82XL-2C/8433-12	HC-A2MVL-2/MV8433N-12
PA23 APACHE	STC-SA4-783	O-340-A1A	HC-82XL-2C/V7636(D,N)	HC-A2MVL-2/MV7636N
PA23 APACHE	STC-SA1-6	O-320-A(1,3)(A,B)	HC-82XG-2/7636D-4	HC-A2MVL-2/MV7636N-4
PA23 SERIES APACHE	STC-SA2-1088	O-320-B3B	HC-82XL-2B/7636D-4	HC-A2MVL-2/MV7636N-4
PA23, PA23-160 APACHE	STC-SA1-5	O-320-A(1,3)(A,B)-150hp	HC-(A,8)2XL-2C/7636D-4	HC-A2MVL-2/MV7636N-4
PA23, PA23-160 APACHE	STC-SA1-5	O-320-(B,C)(1,3)(A,B)	HC-(A,8)2XL-2/7636D-4	HC-A2MVL-2/MV7636N-4
PA23-160 APACHE	1A10	O-320-(B,C)(1,3)(A,B)	HC-82XG-2/7636D	HC-A2MVL-2/MV7636N
PA23-160 APACHE	1A10	O-320-(B,C)(1,3)(A,B)	HC-(8,A)2X(G,L)-2(B,C)/7636D-4	HC-A2MVL-2/MV7636N-4
PA23-235 APACHE	1A10	O-540-B1A5	HC-82XK-2C1, -A2XK-2/8433-10	HC-A2MVK-2/MV8433N-10
PA23-235, 250 AZTEC	STC-SA495CE	O-540-B1A5	HC-A3VK-2B/V7636D-4	HC-A3MVK-2B/MV7636N-4
PA23-235, 250 AZTEC	STC-SA495CE	O-540-A1B5, -A1D5, -A3D5	HC-A3VK-2B/V7636D-4	HC-A3MVK-2B/MV7636N-4
PA23-250 AZTEC	STC-SA164CE	O-540-A1B5, -A3D5, -A1D5	HC-A3XK-2B/7636D-4	HC-A3MVK-2B/MV7636N-4
PA23-250 AZTEC SN<27-2000	1A10	IO-540-C(), O-540-A()	HC-A2XK-2/8433B-10	HC-A2MVK-2/MV8433NB-10
PA23-250 AZTEC SN<27-2505	1A10	IO-540-C(), O-540-A()	HC-82XK-2C1, -A2XK-2//8433-10	HC-A2MVK-2/MV8433N-10
PA24-250 COMANCHE	1A15	O-540-A1();IO-540-C1B5	HC-A2(X,V)K-1,-82XK-1D//8433-7	HC-A2MVK-1/MV8433N-7
PA24-400 COMANCHE	1A15	IO-720-A1A	HC-A3VK-4/V8433-7	HC-A3MVK-4/MV8433N-7
PA24S COMANCHE	STC-SA511WE	O-540-B1B5	HC-A2XK-1/8433-7	HC-A2MVK-1/MV8433N-7
PA28 CHEROKEE	STC-SA222SW	O-320-A2B	HC-82XL-6F/7636D-4	HC-A2MVL-6F/MV7636N-4
PA28-140 CHEROKEE	STC-SA2052SE	O-320-E2A	HC-82XL-6F/8433-12	HC-A2MVL-6F/MV8433N-12
Prop Jets Inc.				
200	3A18	O-470-M	HC-82XF-1DB1,-A2XF-1A/8433S	HC-A2MVF-1A/MV8433NS
200A,B,C	3A18	IO-470-D	HC-82XF-1DB1,-A2XF-1A/8433(R)-4	HC-A2MVF-1A/MV8433N(R)-4
Republic (STOL Amphibian)				
RC3 SEABEE	STC-SA282NW	GO-480-F()	HC-A3XF-5AL/L9333C-6	HC-A3MVF-5AL/LMV9333N-6
RC3 SEABEE	UNK	GSO-480-B1C6	HC-A3V20-3L/LV9333N-6Q	HC-A3MV20-3L/LMV9333N-6Q
RC3 SEABEE	STC-SA3-88	6A8-215-B8F	HC-D3X20-6L/L8433H-2	HC-D3MV20-6L/LMV8433N-2
RC3 SEABEE	STC-SA3-88	6A8-215-B8F	HC-13X20-5L/L8433H-2	not procurable
RC3 SEABEE	STC-SA282NW	GO-480-C1D6	HC-83X20-3L/L9333C-4	HC-A3MV20-3L/LMV9333N-4
RC3 SEABEE	STC-SA282NW	GO-480-B()	HC-83X20-3L/L8433	HC-A3MV20-3L/LMV8433N
RC3 SEABEE	STC-SA615NW	IGSO-540-A1B6	HC-A3V20-3L//LV9333CH-4 or -5	HC-A3MV20-3L/LMV9333N-4 or 5
RC3 SEABEE	STC-SA615NW	GO-435-C2B	HC-A3V20-3L/LV9333N-5, LV9333CH-5	HC-A3MV20-3L/LMV9333N-5
RC3 SEABEE	A769	6A8-215-B8F	HC-12X20-3,-3A,-3C,-3E/L8433	HC-D2MV20-3/LMV8433N
RC3 SEABEE	A769	6A8-215-B8F	HC-12X20-2/L8433	not procurable
RC3 SEABEE	STC-SA282NW	GO-435	HC-83X20-3L//L8433	HC-A3MV20-3L/LMV8433N
RC3 SEABEE	STC-SA282NW	GO-480-C(), -G()	HC-A3XF-5AL/L9333C-4	HC-A3MVF-5AL/LMV9333N-4
Scottish Aviation (BAE)				
B.206 SERIES 2 BEAGLE	A11EU	GTSIO-520-C	HC-A3VF-2D/V8833B	HC-A3MVF-2D/MV8833NB
Stinson				
L-5	STC-	O-435-C	HC-D2X20-8/8433-6	HC-D2MV20-8/MV8433N-6
108, -1, -2, -3	STC-SA4-46	O-435-1	HC-12X20-8D, -D2X20-8/8433-6	HC-D2MV20-8/MV8433N-6
108-2-3	STC-SA1199WE	O-470-A, -J, -K, -L	HC-A2(X,V)F-1/8433	HC-A2MVF-1A/MV8433N
108-2-3	STC-SA4-398	O-435-C	HC-12X20-8D, -D2X20-8/8433-6	HC-D2MV20-8/MV8433N-6

Mar 20/98

HC-SB-61-232
Page 12 of 13

HARTZELL PROPELLER INC.
SERVICE BULLETIN

Propellers
Propeller - Introduction of MV Shank Propellers

Table 2. Aircraft and Propeller Applications

<u>AIRCRAFT MODEL</u>	<u>TC/STC #</u>	<u>ENGINE</u>	<u>OLD PROPELLER/BLADE</u>	<u>CURRENT ("MV" type) PROPELLER/BLADE</u>
Sud Aviation (SOCATA)				
GY.80-150 GARDAN	A12IN	O-320-A3C	HC-82XL-1/7636D-4	HC-A2MVL-1/MV7636N-4
GY.80-160 GARDAN HORIZON	A12IN	O-320-B3C	HC-82XL-1/7636D-4	HC-A2MVL-1/MV7636N-4
Swift				
GC-1B	UNK	IO-320-B1A	HC-82XL-1D/7636D-4	HC-A2MVL-1/MV7636N-4
Taylorcraft				
20	3A3	O-470-A	HC-82XF-1/8433	HC-A2MVF-1A/MV8433N
20	3A3	O-470-J	HC-82XF-1/8433	HC-A2MVF-1A/MV8433N
Texas Bullet				
205	4A2	E-185-1-7	HC-12X20-7/8433-6	HC-D2MV20-7/MV8433N-6
Windecker				
EAGLE	UNK	250-B17C	HC-A3VF-7A/V10133N-17Q	HC-A3MVF-7A/MV10133N-17Q

Mar 20/98