

# HARTZELL PROPELLER INC. SERVICE LETTER

## Propellers

### Propeller - Abnormal Vibration or Grease Leakage

#### 1. Planning Information

##### A. Effectivity

All Hartzell propellers

##### B. Reason

Serious propeller defects may give indications prior to failure, such as sudden or abnormal grease leakage or vibration during operation. Several catastrophic failures have been prevented by thorough and timely inspection techniques at the onset of such indications. Operators need to be aware of the possibility that prudent action to investigate abnormal grease leaks or vibration may prevent blade retention failures.

##### C. Description

This service letter provides a warning that all propellers need to be inspected in the event that any sudden or abnormal propeller grease leakage or vibration is experienced.

This service letter also provides the initial procedures for investigation of abnormal grease leaks or vibration. The intent is to provide guidance to operators and aircraft mechanics when encountering these conditions. Accomplishment instructions may be performed by a certificated aircraft mechanic.

##### D. Approval

FAA approval has been obtained on technical data in this publication that affects type design.

##### E. References

- (1) Service Bulletin 164C (or subsequent revision) addresses incidents of cracks in two blade aluminum hubs.
- (2) Service Bulletin 165E (or subsequent revision) addresses incidents of cracks in three blade aluminum hubs.
- (3) To obtain copies of Hartzell service literature and revisions, contact:

Hartzell Propeller Inc. Telephone: 513.778.4200  
Attn: Service Documents Secretary Fax: 513.778.4391  
One Propeller Place  
Piqua, Ohio 45356 U.S.A .

##### F. Publications Affected

Propeller Owner's Manuals 106( ), 115( ), 139( ), 149( ), and 154( ) will be revised to incorporate this service letter.

# HARTZELL PROPELLER INC.

# SERVICE LETTER

## Propellers

### Propeller - Abnormal Vibration or Grease Leakage

#### 2. Accomplishment Instructions

WARNING: ABNORMAL GREASE LEAKAGE OR VIBRATION CAN BE AN INDICATION OF A FAILING PROPELLER BLADE OR BLADE RETENTION COMPONENT. AN IN-FLIGHT BLADE SEPARATION CAN RESULT IN A CATASTROPHIC AIRCRAFT ACCIDENT.

NOTE: Even though blade separations are extremely rare and most leakage and vibration problems are not caused by a failing blade retention component, all reports of abnormal grease leakage or vibration demand a thorough investigation prior to further flight. This is necessary because a timely investigation of such conditions has proven to be effective in preventing propeller failures. Slight vibration that has occurred over an extended period of time or slight grease leakage (or even moderate grease leakage) that occurs at a constant rate over an extended period of time are conditions that may require correction but are not necessarily alarming conditions that demand immediate inspection and repair. In incidents where cracked blade retention parts have been found after investigation, the situation was most often described as a grease leak or vibration that initiated suddenly and is unexplainable. If a grease leak or vibration can be described as "sudden", "unusual", or "abnormal", then the following action is necessary.

#### A. Inspection of **Abnormal Grease Leak** - if the cause is not evident:

- (1) Remove spinner dome.

NOTE: Perform visual inspection without cleaning of parts. A tight crack is often evident due to traces of grease emanating from the crack. Cleaning can remove such evidence and make a crack more difficult to see visually.

- (2) Perform visual inspection for cracks in the hub and blade retention areas.
  - (a) On steel hub propellers pay particular attention to the steel blade clamps, see Figure 1.
  - (b) On aluminum hub propellers pay particular attention to the blade retention areas of the hub, see Figure 2.

NOTE: Figures 1 & 2 show examples of past incidents where cracks have been found. The areas shown should not be the only area inspected.

# HARTZELL PROPELLER INC.

# SERVICE LETTER

## Propellers

### Propeller - Abnormal Vibration or Grease Leakage

- (3) Perform visual inspection of the hub and blade retention areas to locate the origin of leakage. If the origin of grease leakage is determined to be a noncritical part such as an O-ring or sealant, repairs can be accomplished during scheduled maintenance.
- (4) If suspected cracks are found, before further flight, perform additional inspections (by qualified personnel at an approved propeller repair station) to verify the condition. Such inspections typically include disassembly of the propeller with dye penetrant, eddy current, or magnetic particle inspection of parts in accordance with published procedures.
- (5) If cracks or failing components are found, parts must be replaced prior to further flight. Such incidents need to be reported to airworthiness authorities and Hartzell Propeller Inc.

#### B. Inspection of Abnormal Vibration - if the cause is not evident:

NOTE: It may sometimes be difficult to readily identify the cause of abnormal vibration. It may originate in the engine, propeller, or airframe. Troubleshooting procedures typically initiate with investigation of the engine. Airframe components (such as engine mounts or loose landing gear doors) can also be the source of vibration. When investigating an abnormal vibration, the possibility of a failing blade retention component needs to be considered as one of the potential sources of the problem.

- (1) Perform troubleshooting and evaluation of possible sources of vibration in accordance with engine or airframe manufacturer's instructions. If no cause is found, then consider the origin of the problem could be the propeller and proceed with steps 2 through 7.
- (2) Remove spinner dome.
- (3) Perform visual inspection for cracks in the hub and blade retention areas.
  - (a) On steel hub propellers pay particular attention to the steel blade clamps, see Figure 1.
  - (b) On aluminum hub propellers pay particular attention to the blade retention areas of the hub, see Figure 2.

NOTE: Figures 1 & 2 show examples of past incidents where cracks have been found. The areas shown should not be the only area inspected.

# HARTZELL PROPELLER INC. **SERVICE LETTER**

## Propellers

### **Propeller - Abnormal Vibration or Grease Leakage**

- (4) Check blades and compare blade to blade differences:
  - (a) Inspect the propeller blades for unusual looseness or movement.
  - (b) Check blade track.
  - (c) Manually (by hand) attempt to turn blades (change pitch). Do not use blade paddles.
  - (d) Visually check for bent or damaged blades.
- (5) If suspected cracks are found, perform additional inspections (by qualified personnel at an approved propeller repair station) to verify the condition. Such inspections typically include disassembly of the propeller with dye penetrant, eddy current, or magnetic particle inspection of parts in accordance with published procedures.
- (6) If abnormal blade conditions (bent, damaged, etc.) are found, perform additional inspections (by qualified personnel at an approved propeller repair station) to evaluate the condition.
- (7) If cracks or failing components are found, parts must be replaced prior to further flight. Such incidents need to be reported to airworthiness authorities and Hartzell Propeller Inc.

HARTZELL PROPELLER INC.  
**SERVICE LETTER**

Propellers

**Propeller - Abnormal Vibration or Grease Leakage**

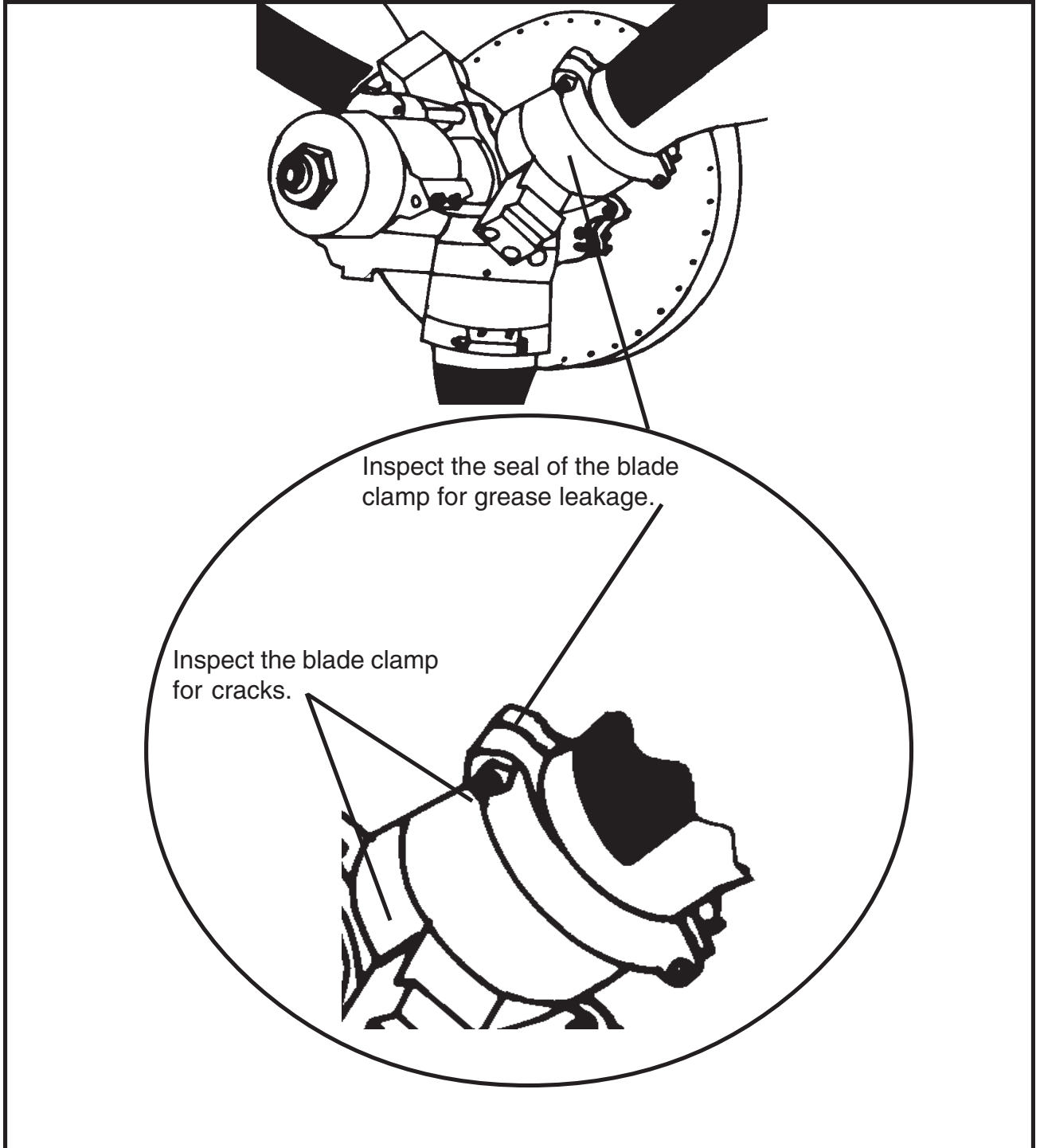

**Steel Hub Clamp  
Figure 1**

# HARTZELL PROPELLER INC. SERVICE LETTER

## Propellers

### Propeller - Abnormal Vibration or Grease Leakage

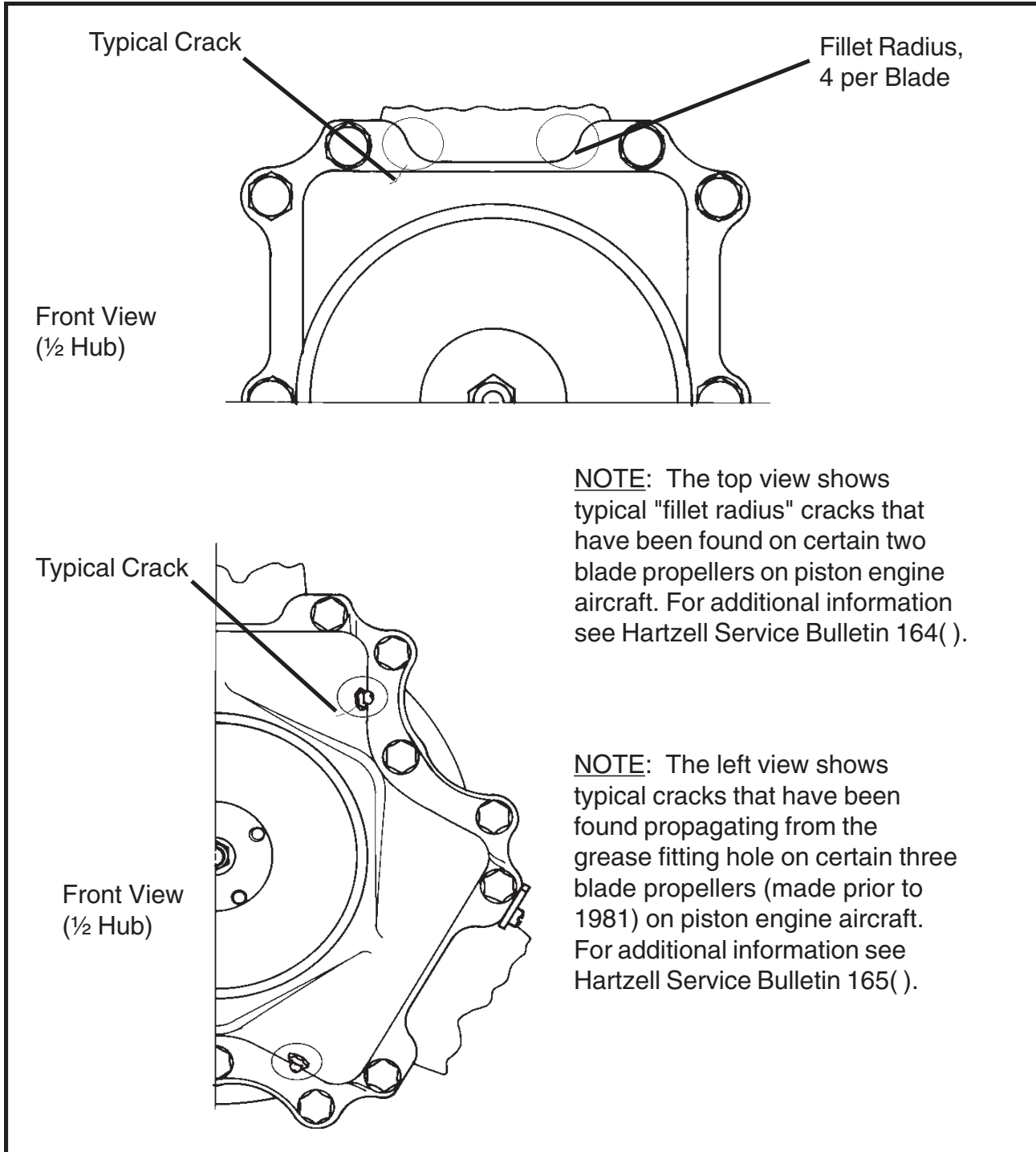

**Aluminum Hubs  
Figure 2**