

HARTZELL PROPELLER INC.
SERVICE BULLETIN
TRANSMITTAL SHEET
HC-SB-61-269
Propeller - Hub Inspection

August 27, 2012

This page transmits a revision to Service Bulletin HC-SB-61-269.

- Original Issue, dated Apr 18/05
- Revision 1, dated Jun 01/06
- Revision 2, dated Sep 28/06
- Revision 3, dated Sep 17/07
- Revision 4, dated Nov 13/09
- Revision 5, dated Jan 14/11
- Revision 6, dated Aug 27/12

Propeller assemblies that have previously complied with the terminating action requirements in a previous version of this Service Bulletin are not affected.

Propeller assemblies that have not previously complied with the terminating action requirements in a previous version of this Service Bulletin are affected.

FAA approval has been obtained on technical data in this publication that affects type design.

Changes are shown by a change bar in the left margin of the revised pages.

This revision is issued to change the following in the Service Bulletin:

- Adds an optional Terminating Action for conversion of hubs without an "A" or "B" serial number suffix
- Revises the document to latest caution and format requirements
- Removes the Appendix (all warranty programs have expired)

HARTZELL PROPELLER INC.
SERVICE BULLETIN
TRANSMITTAL SHEET
HC-SB-61-269
Propeller - Hub Inspection

(This page is intentionally blank.)

HARTZELL PROPELLER INC.
SERVICE BULLETIN
HC-SB-61-269
Propeller - Hub Inspection

1. Planning Information

A. Effectivity

- (1) Hartzell two blade, aluminum hub, "compact" ()HC-()2Y(K,R)-() series propellers manufactured before December 1991 and have no suffix letter, or have an "E" suffix letter at the end of the hub and propeller serial number and installed on Lycoming 360 series engines are affected by this Service Bulletin. Propellers with a suffix letter "A" or "B" at the end of the hub and propeller serial number are not affected by this Service Bulletin.
 - (a) For non-suffix and "E" suffix serial number hubs/propellers installed on Socata TB-10 and TB-200 aircraft, refer to Hartzell Service Bulletin HC-SB-61-323.
- (2) Propellers installed on aircraft listed in Table 1 are not affected by this Service Bulletin. Propellers installed on these applications must comply with the inspection requirements specified in Hartzell Service Bulletin HC-SB-61-227 and Airworthiness Directive 2001-23-08.

NOTE 1: The parenthesis shown in the model designations throughout this Service Bulletin indicate letter(s) and/or number(s) that may or may not be present because of different configurations permitted on the various aircraft installations. Definition of propeller model designations and further details of letters that may be present are shown in Figure 1.

NOTE 2: Hub and propeller serial numbers without suffix letter "A" or "B" were manufactured before 1991 and can be identified by two different styles of the fillet radius as shown in Figure 2. The "E" suffix letter is added to the hub with no suffix serial number to indicate that the initial eddy current inspection has been performed in accordance with this Service Bulletin and a repetitive eddy current inspection is required.

CAUTION: DO NOT USE OBSOLETE OR OUTDATED INFORMATION. PERFORM ALL INSPECTIONS OR WORK IN ACCORDANCE WITH THE MOST RECENT REVISION OF THIS SERVICE BULLETIN. INFORMATION CONTAINED IN THIS SERVICE BULLETIN MAY BE SIGNIFICANTLY CHANGED FROM EARLIER REVISIONS. FAILURE TO COMPLY WITH THIS ALERT SERVICE BULLETIN OR THE USE OF OBSOLETE INFORMATION MAY RESULT IN DEATH, SERIOUS BODILY INJURY, AND/OR SUBSTANTIAL PROPERTY DAMAGE. REFER TO THE SERVICE BULLETIN INDEX FOR THE MOST RECENT REVISION LEVEL OF THIS SERVICE BULLETIN.

HARTZELL PROPELLER INC.
SERVICE BULLETIN
HC-SB-61-269
Propeller - Hub Inspection

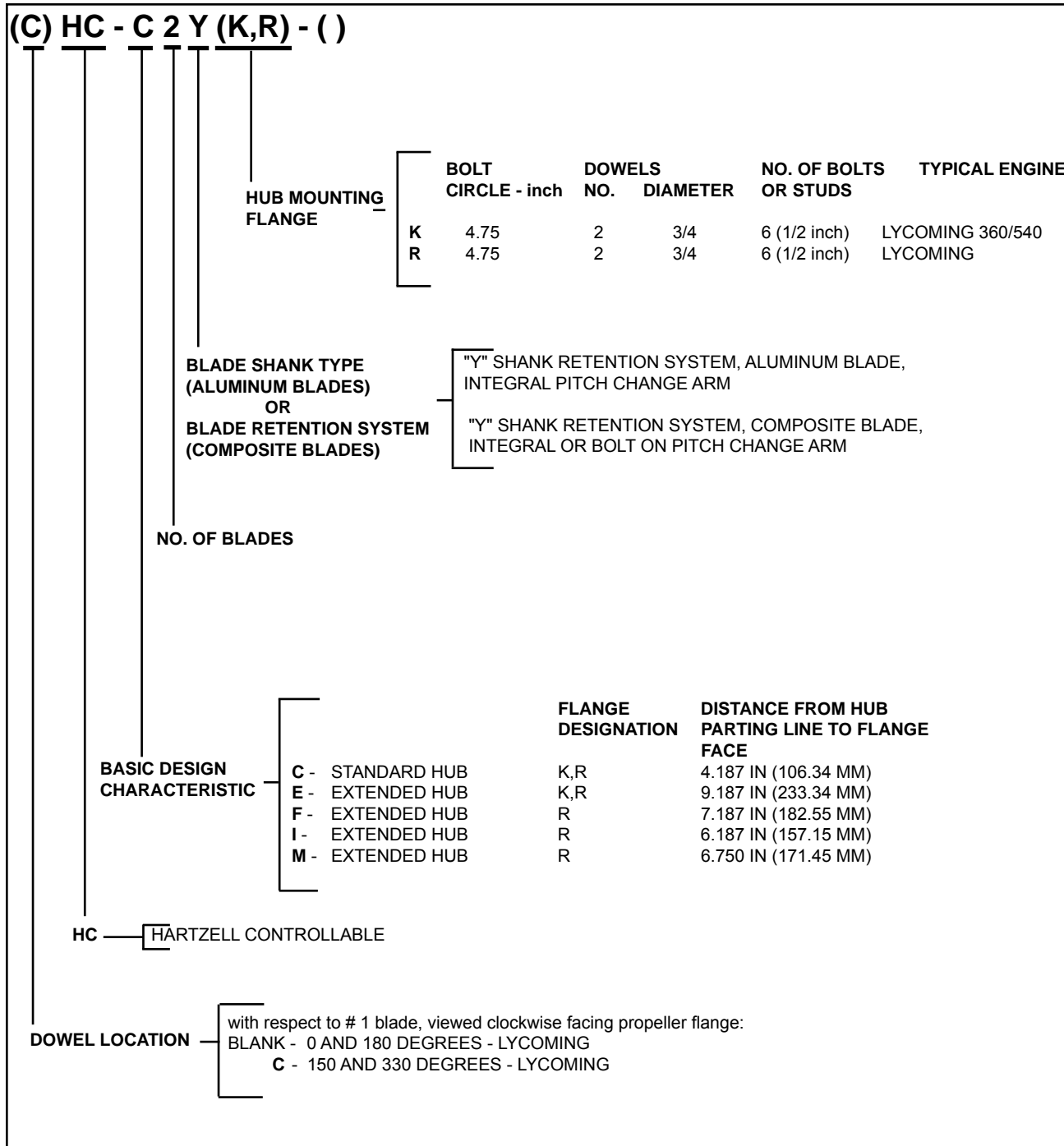

Model Designations for Affected Aluminum Hub, Reciprocating Engine Propellers
Figure 1

HARTZELL PROPELLER INC.
SERVICE BULLETIN
HC-SB-61-269
Propeller - Hub Inspection

- (3) For "A" or "AE" suffix serial number hubs/propellers installed on Socata TB-10 and TB-200 aircraft, refer to Hartzell Service Bulletin HC-SB-61-323.
- (4) Applications that have NOT previously complied with the terminating action in a previous revision of this Service Bulletin or with the terminating action in FAA Airworthiness Directive 2006-18-15 or Airworthiness Directive 2009-22-03 ARE affected by this Service Bulletin.
- (5) Applications that have previously complied with the terminating action in a previous revision of this Service Bulletin or with the terminating action in FAA Airworthiness Directive 2006-18-15 or Airworthiness Directive 2009-22-03 are NOT affected by this Service Bulletin.

B. Concurrent Requirements

- (1) Hartzell Service Bulletin HC-SB-61-227 and AD 2001-23-08 may be applicable instead, depending on the aircraft and engine type. Refer to Table 1.
- (2) For Socata TB-10 or TB-200 aircraft that have a Lycoming 360 series engine, Hartzell Service Bulletin HC-SB-61-323 is applicable instead.
- (3) Installation of a "B" serial number suffix hub will require spinner bulkhead modification or replacement in accordance with the Repair and Modification chapter of Hartzell Spinner Assembly Maintenance Manual 127 (61-16-27).
 - (a) Applications with non-Hartzell spinner assemblies should contact the appropriate Type Certificate holder for rework instructions.
- (4) Hartzell Alert Service Bulletin HC-ASB-61-297 is applicable for left-hand rotating propellers.

Propellers installed on the following applications are not affected by this Service Bulletin. Propellers installed on these applications must comply with the inspection requirements specified in Hartzell Service Bulletin HC-SB-61-227 and AD 2001-23-08.

- (1) Aerobatic aircraft (including certificated aerobatic aircraft, military trainers, or any aircraft routinely exposed to aerobatic usage)
- (2) Agricultural aircraft
- (3) Piper PA-32() series aircraft with Lycoming 540 series engines rated at 300 HP or higher
- (4) Britten Norman BN-2() series aircraft with Lycoming 540 series engines

Propellers Not Affected by this Service Bulletin
Table 1

HARTZELL PROPELLER INC.
SERVICE BULLETIN
HC-SB-61-269
Propeller - Hub Inspection

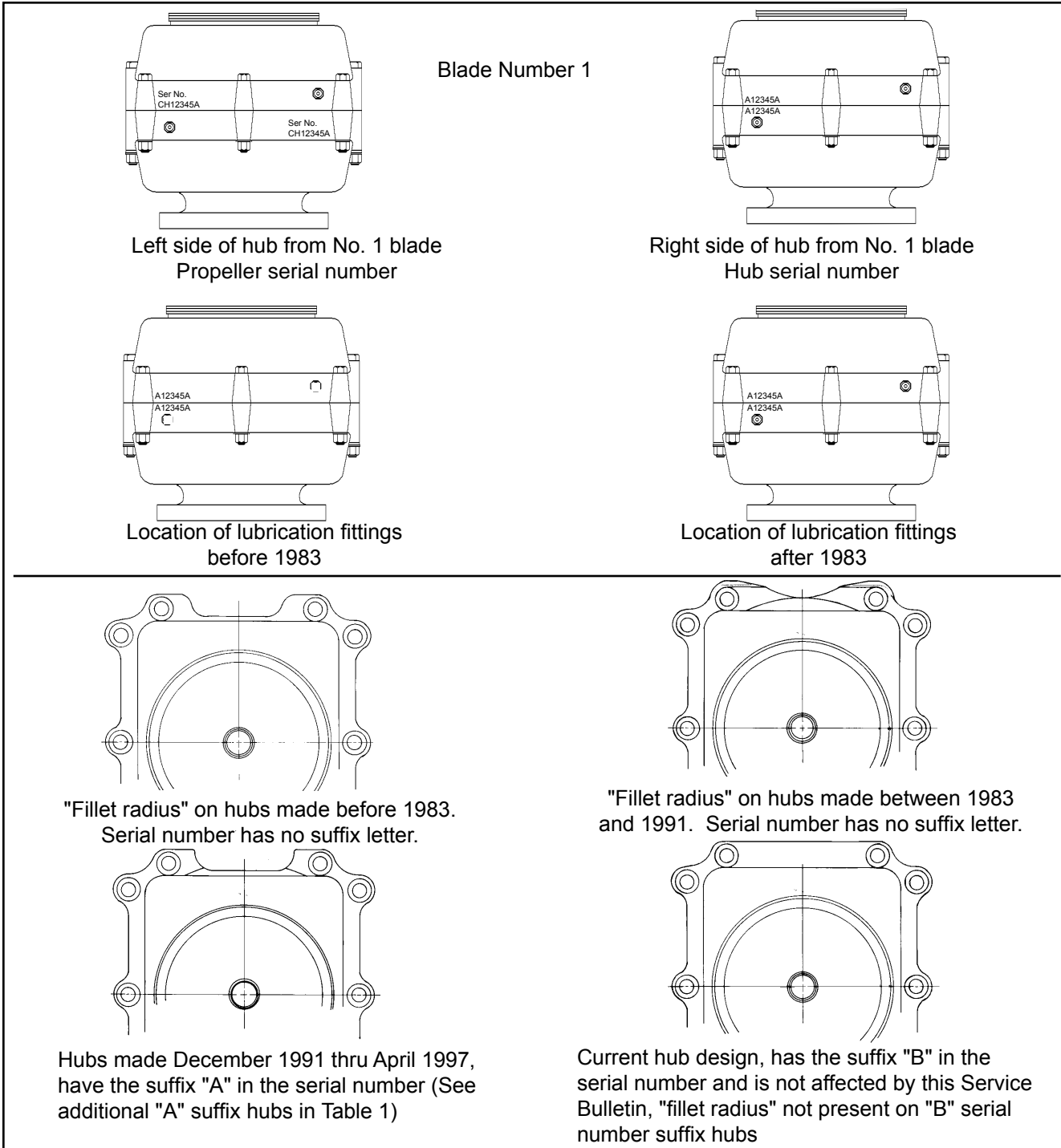

Hub Identification
Figure 2

HARTZELL PROPELLER INC.
SERVICE BULLETIN
HC-SB-61-269
Propeller - Hub Inspection

- (5) Additional service documents may apply to the components/propellers affected by this Service Bulletin. Compliance with additional service documents may be necessary in conjunction with the completion of the Accomplishment Instructions in this Service Bulletin. Refer to the Hartzell Propeller website at www.hartzellprop.com for a cross-reference of service documents.

C. Reason

WARNING: UNUSUAL OR ABNORMAL GREASE LEAKAGE OR VIBRATION, WHERE THE CONDITION INITIATED SUDDENLY, CAN BE AN INDICATION OF A FAILING PROPELLER BLADE OR BLADE RETENTION COMPONENT. AN INFLIGHT BLADE SEPARATION MAY RESULT IN DEATH, SERIOUS BODILY INJURY, AND/OR SUBSTANTIAL PROPERTY DAMAGE. UNUSUAL OR ABNORMAL GREASE LEAKAGE OR VIBRATION DEMANDS IMMEDIATE INSPECTION FOR POSSIBLE CRACKED HUB (FOR FURTHER INFORMATION ABOUT THIS SUBJECT REFER TO HARTZELL SERVICE LETTER HC-SL-61-165).

- (1) There have been numerous occurrences of hub fillet cracks, including incidents of in-flight blade separation in Hartzell two blade "compact" series aluminum hub propellers.
- (2) Cracks were typically discovered during an inspection following reports of abnormal vibration or grease leakage. Cracks typically initiate at the same region of the hub in the area adjacent to the blade called the "fillet radius". As the cracks propagate toward the center of the hub, their progression accelerates and may result in failure of one hub half that can further progress to blade separation.
- (3) Airworthiness Directive 2009-22-03 was issued to address the inspection requirements specified in this Service Bulletin.
- (a) Airworthiness Directive 2006-18-15 that was previously issued to address the inspection requirements specified in this Service Bulletin has been superseded by Airworthiness Directive 2009-22-03.

D. Description

- (1) This document provides Instructions for Continuing Airworthiness (ICA).
- (2) This Service Bulletin provides requirements for an initial and repetitive eddy current inspection of the propeller hub fillet radius of hubs that do not have an "A" or "B" serial number suffix or do have an "E" serial number suffix.

HARTZELL PROPELLER INC.
SERVICE BULLETIN
HC-SB-61-269
Propeller - Hub Inspection

- (3) This Service Bulletin provides optional replacement of an affected non-suffix or "E" serial number suffix hub with an "A" or "B" suffix hub as a terminating action for this Service Bulletin.

NOTE 1: Installation of a hub with an "AE" suffix serial number is not approved as terminating action for this Service Bulletin. A hub with an "AE" suffix serial number is affected by Hartzell Service Bulletin HC-SB-61-227 or Hartzell Service Bulletin HC-SB-61-323 and may not be installed on another aircraft application that does not have the same inspection requirements.

NOTE 2: Installation of a hub with an "A" suffix serial number is not approved as terminating action for the Socata TB-10 or TB-200 aircraft. Refer to Hartzell Service Bulletin HC-SB-61-323 for Socata TB-10 and TB-200 applications.

NOTE 3: A hub with a "B" suffix serial number is the current design. This design does not have a fillet radius. The fillet radius is the area of crack initiation. A hub with an "A" suffix serial number has a modified fillet radius. Installation of a "B" suffix hub is the recommended terminating action for this Service Bulletin.

- (4) Revision 4 changed the compliance period, with no calendar limit specified, and clarifies the Initial Compliance requirements.
- (5) Revision 5 changes the effectivity to exclude propellers installed on Socata TB-10 and TB-200 aircraft, which are now affected under Hartzell Service Bulletin HC-SB-61-323.
- (6) Revision 6 introduces the optional terminating action of converting to the oil-filled configuration for hubs without an "A" or "B" suffix serial number.

E. Compliance

- (1) Initial Inspection - Perform the eddy current inspection described in this Service Bulletin within 50 hours from April 18, 2005 (the effective date of the original issue of this Service Bulletin).
- (a) If an affected propeller has previously complied with the Initial Inspection requirement in accordance with an earlier revision of this Service Bulletin or Airworthiness Directive 2006-18-15, Initial Inspection in accordance with Airworthiness Directive 2009-22-03 or with this revision of this Service Bulletin is not required.

HARTZELL PROPELLER INC.
SERVICE BULLETIN
HC-SB-61-269
Propeller - Hub Inspection

- (b) Repetitive inspection is required for all affected propellers until the hub is replaced in accordance with the Terminating Action requirements of this Service Bulletin.
- (2) Repetitive Inspection - Perform the eddy current inspection described in this Service Bulletin at repetitive intervals not to exceed 100 hours of operation.

CAUTION: DO NOT INSTALL A REPLACEMENT HUB AS TERMINATING ACTION WITH AN "A" SUFFIX SERIAL NUMBER IF IT WAS PREVIOUSLY INSTALLED ON AN APPLICATION AFFECTED BY HARTZELL SERVICE BULLETIN HC-SB-61-227 OR HARTZELL SERVICE BULLETIN HC-SB-61-323.

- (3) Optional Terminating Action - Replacement of the non-suffix or "E" suffix propeller hub with a hub with an "A" or "B" suffix serial number is a terminating action for this Service Bulletin. "B" Suffix hubs may have a different part number and will be identified by suffix letter "B" at the end of the propeller serial number. Contact Hartzell Propeller Product Support for part number information.

NOTE 1: Installation of an "A" or "B" suffix serial number hub is also terminating action for the repetitive eddy current inspection required in accordance with Hartzell Service Bulletin HC-ASB-61-297.

NOTE 2: A propeller hub from an aircraft that is affected by this Service Bulletin is not to be removed and reused on another aircraft application that does not have these inspection requirements.

NOTE 3: A hub with a "B" suffix serial number is the current design. This design does not have a fillet radius. The fillet radius is the area of crack initiation. A hub with an "A" suffix serial number has a modified fillet radius. Installation of a "B" suffix hub is the recommended terminating action for this Service Bulletin.

NOTE 4: Installation of a hub with an "A" suffix serial number is not approved as terminating action for Socata TB-10 or TB-200 aircraft. Refer to Hartzell Service Bulletin HC-SB-61-323 for Socata TB-10 and TB-200 applications.

HARTZELL PROPELLER INC.
SERVICE BULLETIN
HC-SB-61-269
Propeller - Hub Inspection

(4) Propeller hub modification:	
Propeller Removal/Installation	2.0 man-hours
Propeller Disassembly/Assembly	4.0 man-hours
Propeller Hub Modification	<u>2.0 man-hours</u>
Total man-hours	8.0 man-hours
If required, Teflon Removal/Installation	1.0 man-hours per blade

NOTE: Hub disassembly/assembly and Teflon® removal/installation do not require additional labor when accomplished in conjunction with propeller overhaul.

H. Weight and Balance

- (1) There is no increase in weight with installation of a hub with suffix letter "A" in the serial number.
- (2) There is 0.50 lb. increase in weight with installation of a hub with suffix letter "B" in the serial number.
- (3) There is a 0.50 lb. (0.23 kg) increase in weight with hub modification to the oil-filled configuration.

I. Electrical Load Data

- (1) Not Changed

CAUTION: DO NOT USE OBSOLETE OR OUTDATED INFORMATION. PERFORM ALL INSPECTIONS OR WORK IN ACCORDANCE WITH THE MOST RECENT REVISION OF ALL DOCUMENTS.

J. References

- (1) Hartzell Compact and Lightweight Compact Non-Feathering (-1) and Aerobatic (-4) Propeller Overhaul and Maintenance Manual 113B (61-10-13)
- (2) Hartzell Propeller Owner's Manual 115N (61-00-15)
- (3) Hartzell Compact Constant Speed and Feathering Propeller Overhaul and Maintenance Manual 117D (61-10-17)
- (4) Hartzell Metal Spinner Maintenance Manual 127 (61-16-27)
- (5) Hartzell Propeller Owner's Manual 145 (61-00-45)
- (6) Hartzell Standard Practices Manual 202A (61-01-02)
- (7) Hartzell Service Bulletin HC-SB-61-227
- (8) Hartzell Alert Service Bulletin HC-ASB-61-297

HARTZELL PROPELLER INC.
SERVICE BULLETIN
HC-SB-61-269
Propeller - Hub Inspection

W10571D.eps
Cir-W10571D.ai

Typical crack

NOTE: The hub clamping bolt holes and the balance weight holes are not included in the areas to be inspected.

Inspect the shaded area

Inspect the shaded area

Hub clamping bolt hole

Balance weight hole

Inspect two highlighted areas on each blade socket (forward hub half) during on-wing inspection, and four locations (both hub halves) during overhaul inspection.

Socket Fillet Radius Inspection
Figure 3

HARTZELL PROPELLER INC.
SERVICE BULLETIN
HC-SB-61-269
Propeller - Hub Inspection

- (9) Hartzell Service Bulletin HC-SB-61-323
- (10) Hartzell Service Letter HC-SL-61-165
- (11) [Hartzell Service Letter HC-SL-61-273](#)
- (12) [Airworthiness Directive 2001-23-08](#)
- (13) [Airworthiness Directive 2006-18-15](#)
- (14) [Airworthiness Directive 2009-22-03](#)

K. Other Publications Affected

- (1) None

2. Material Information

A. Parts Required

- (1) If a hub must be replaced, contact Hartzell Propeller Product Support for the current hub part number.

Hartzell Propeller Product Support
One Propeller Place
Piqua, Ohio 45356 USA
Phone: (001) 937.778.4379 / 800.942.7767
Fax: (001) 937.778.4391
E-mail: techsupport@hartzellprop.com

- (2) Refer to Hartzell Metal Spinner Maintenance Manual 127 (61-16-27) for spinner bulkhead replacement part numbers and/or modification information.

B. Special Tooling

- (1) An Eddy Current Instrument is required. Refer to Hartzell Standard Practices Manual 202A (61-01-02) for details.

C. Material Necessary for Propeller Modification to the oil-filled configuration:

- (1) Refer to Hartzell Service Letter HC-SL-61-273 for a complete list of requirements.

3. Accomplishment Instructions

A. Hub Inspection

- (1) Inspection of the fillet radii on the (front) cylinder half of the propeller hub may be performed "on-wing" without removing the propeller from the engine.

HARTZELL PROPELLER INC.
SERVICE BULLETIN
HC-SB-61-269
Propeller - Hub Inspection

- (2) This inspection must be accomplished by qualified personnel at an appropriately licensed propeller repair facility or certificated aircraft mechanic with an eddy current qualification in accordance with Hartzell Standard Practices Manual 202A (61-01-02).
- (3) If inspection is performed during propeller overhaul or if the propeller has been removed from the aircraft and disassembled, both halves of the hub are to be inspected in accordance with Hartzell Standard Practices Manual 202A (61-01-02).
- (4) On-Wing Inspection Procedure:
 - (a) Remove the spinner dome in accordance with the applicable owner's manual.
 - (b) If the propeller has blade counterweights, position the blades to provide maximum exposure of the forward hub half fillet radius area.

NOTE: If the propeller does not have blade counterweights, special positioning of blades is not required.

- 1 For propeller models ()HC-()2Y()-2() with counterweighted propeller blades, perform engine run and shut down with propeller blades in the feathered position. This will position the blade counterweights to provide maximum exposure of the forward hub half fillet radius area.

WARNING 1: DO NOT USE BLADE PADDLES TO FEATHER THE PROPELLER. IT IS POSSIBLE FOR EXCESSIVE LOADS TO BE APPLIED WITH BLADE PADDLES AND RESULT IN HIDDEN DAMAGE TO THE PITCH CHANGE MECHANISM.

WARNING 2: CARE MUST BE TAKEN TO UNFEATHER THE PROPELLER IN ACCORDANCE WITH SECTION 3.(A)(4).

- 2 For propeller models ()HC-()2Y()-4() with counterweighted propeller blades (used on aerobatic aircraft), manually turn blades from high to low pitch to move the counterweight away from the inspection area (there is no pitch return spring in these propellers and the blades can be turned manually without the use of blade paddles). This will position the blade counterweights to provide maximum exposure to the forward hub half fillet radius area.

HARTZELL PROPELLER INC.
SERVICE BULLETIN
HC-SB-61-269
Propeller - Hub Inspection

CAUTION: BALANCE WEIGHTS MUST BE RETURNED TO THE SAME LOCATION ON THE HUB FROM WHICH THEY WERE REMOVED.

(c) Remove balance weights and make note of location as necessary.

NOTE: ()HC-()2Y()-(2)() propellers with balance weights installed may require removal from the aircraft for disassembly to allow removal of the balance weights behind the counterweights.

(d) Before any cleaning, visually inspect for a cracked hub in the area of the hub fillet radii (a cracked hub can have traces of grease coming from the crack making the crack more visible).

NOTE: Hartzell Alert Service Bulletin HC-ASB-61-297 requires an eddy current inspection of the area around the lubrication fitting holes.

(e) Clean the surface of the hub to remove oil, grease, or other contaminants that may interfere with the efficiency of the eddy current inspection.

NOTE: Paint removal is not required for eddy current inspection.

(f) Perform eddy current inspection in accordance with Hartzell Standard Practices Manual 202A (61-01-02). Refer to Figure 3.

NOTE: The balance weight attachment hole and hub clamping bolt hole do not require eddy current inspection.

(5) If a crack indication is found, hub replacement is required before further flight. Report any findings of a cracked hub to the Hartzell Propeller Product Support Department.

(6) If no crack indications are found,

(a) After the first inspection only, permanently identify the hub to indicate compliance with this Service Bulletin. Use a metal impression stamp (0.125 inch [3.175 mm]), round bottom characters) to stamp the letter "E" at the end of the propeller serial number in accordance with Hartzell Standard Practices Manual 202A (61-01-02). For example, propeller serial number DN1234 would be changed to DN1234E. This change is to be noted in the propeller logbook so that it provides further indication that this Service Bulletin is applicable.

HARTZELL PROPELLER INC.
SERVICE BULLETIN
HC-SB-61-269
Propeller - Hub Inspection

CAUTION: BALANCE WEIGHTS MUST BE RETURNED TO THE SAME LOCATION ON THE HUB FROM WHICH THEY WERE REMOVED.

- (b) Reinstall balance weights and fasteners from the location they were removed. Refer to the Static and Dynamic Balance chapter of Hartzell Standard Practices Manual 202A (61-01-02).
- (7) If blades were required to be placed in the feather position to perform this inspection, the blades may be unfeathered using the procedure below:
- (a) Remove the valve cap.
 - (b) Using a suitable device, depress the valve stem to relieve the air charge from the cylinder.

CAUTION 1: REPOSITION BLADES WITH CARE. DO NOT USE A SINGLE BLADE PADDLE TO REPOSITION BLADES. IT IS POSSIBLE FOR EXCESSIVE LOADS TO BE APPLIED WITH BLADE PADDLES AND RESULT IN HIDDEN DAMAGE TO THE PITCH CHANGE MECHANISM.

CAUTION 2: DO NOT PUT BLADE PADDLES ON DEICE BOOTS, AS BOOTS MAY BE DAMAGED.

- (c) Using a blade paddle on each blade, simultaneously move both blades from the feather position to the low pitch position.
 - (d) Remove the blade paddles.
 - (e) For propellers that use an air charge, recharge the cylinder in accordance with the applicable owner's manual.
 - 1 Reinstall the air valve cover cap and spinner dome in accordance with the applicable owner's manual.
 - (f) Proceed to section 3.A.(9).
- (8) If the blades were not required to be feathered to perform this inspection, reinstall the spinner dome in accordance with the applicable Hartzell Propeller Owner's Manual.
- (9) Make an entry in the propeller logbook indicating compliance with the hub inspection requirement of this Service Bulletin noting the time for the next inspection.

HARTZELL PROPELLER INC.
SERVICE BULLETIN
HC-SB-61-269
Propeller - Hub Inspection

B. Hub Replacement

- (1) Hub replacement must be performed by qualified personnel at an appropriately licensed propeller service facility in accordance with the applicable propeller overhaul manual. Replacement of the existing hub with a hub identified by an "A" or "B" suffix letter in the propeller serial number is terminating action for this Service Bulletin.
 - (a) Do not install an "A" or "AE" suffix hub previously installed on an aircraft affected by Hartzell Service Bulletin HC-SB-61-227 or Hartzell Service Bulletin HC-SB-61-323. See Notes on page 7 of this Service Bulletin.
- (2) A hub without a suffix letter or with an "E" suffix letter in the serial number that is removed from aircraft applications affected by this Service Bulletin [as defined in Effectivity, paragraph 1.A.(1)] is not to be reused on another aircraft application that does not have such inspection requirements, including experimental applications. See Notes on page 7 of this Service Bulletin.
 - (a) A hub removed from an affected aircraft must either be installed on another affected application, or be retired. Refer to the Part Retirement Procedures in Hartzell Standard Practices Manual 202A (61-01-02).
- (3) For spinner bulkhead modification or replacement part numbers, refer to the Repair and Modification chapter of Hartzell Metal Spinner Maintenance Manual 127 (61-16-27).
- (4) Make an entry in the propeller logbook indicating compliance with the hub replacement instructions as terminating action for this Service Bulletin.

C. Optional Propeller Modification to the Oil-filled Configuration

WARNING: MODIFICATION TO THE OIL-FILLED CONFIGURATION IS ONLY APPROVED FOR PROPELLERS AFFECTED BY THIS SERVICE BULLETIN INSTALLED ON A LYCOMING 360 SERIES ENGINE.

- (1) Affected propeller models without an "A" or "B" suffix serial number may be modified to the oil-filled configuration as terminating action for this Service Bulletin.
 - (a) Modification of the propeller hub to the oil-filled configuration must be performed by qualified personnel at an appropriately licensed propeller service facility.
 - (b) Modification of the propeller hub to the oil-filled configuration must be performed in accordance with Hartzell Service Letter HC-SL-61-273.
 - (c) A propeller modified to the oil-filled configuration, must not be restored to the grease lubricated configuration.

HARTZELL PROPELLER INC.
SERVICE BULLETIN
HC-SB-61-269
Propeller - Hub Inspection

- (2) Make an entry in the propeller logbook indicating compliance with the Propeller Modification to the Oil-filled Configuration instructions as terminating action for this Service Bulletin.

D. Recommended Service Facilities

- (1) Hartzell Propeller has a worldwide network of Recommended Service Facilities that are recommended by Hartzell Propeller for overhaul and repair of our products.
- (2) Each service facility must meet standard FAA requirements and additional Hartzell Propeller requirements before being recommended by Hartzell Propeller. Each Recommended Service Facility is audited by Hartzell Propeller to verify the continuation of the standards.
- (3) Hartzell Propeller recommends that you use one of these service facilities when having your propeller overhauled or repaired.
- (4) For a current list of Hartzell Propeller Recommended Service Facilities, contact Hartzell Product Support or refer to the Hartzell Propeller website at www.hartzellprop.com.

E. Contact Information

Hartzell Propeller Inc.
Attn.: Hartzell Product Support
One Propeller Place
Piqua, Ohio 45356-2634 USA
Phone: (001) 937.778.4379
Fax: (001) 937.778.4391
E-mail: techsupport@hartzellprop.com