

Manual No. 145
61-00-45
Revision 11
December 2012

Propeller Owner's Manual and Logbook

“Compact” and “Lightweight Compact” Models
with Composite Blades

Compact Constant Speed, Non-counterweighted
()HC-()Y()-1()

Compact Constant Speed and Feathering
HC-()Y()-2()

Compact Constant Speed, Counterweighted
HC-()Y()-4()

Lightweight Compact Constant Speed, Non-counterweighted
()HC-()Y1()-1()

Hartzell Propeller Inc.

One Propeller Place
Piqua, OH 45356-2634 U.S.A.
Ph: 937-778-4200 (Hartzell Propeller Inc.)
Ph: 937-778-4379 (Product Support)
Product Support Fax: 937-778-4391

© 1999, 2004, 2006, 2008, 2009, 2010, 2011, 2012- Hartzell Propeller Inc.
All rights reserved

As a fellow pilot, I urge you to read this Manual thoroughly. It contains a wealth of information about your new propeller.

The propeller is among the most reliable components of your airplane. It is also among the most critical to flight safety. It therefore deserves the care and maintenance called for in this Manual. Please give it your attention, especially the section dealing with Inspections and Checks.

Thank you for choosing a Hartzell propeller. Properly maintained it will give you many years of reliable service.



Jim Brown
Chairman, Hartzell Propeller Inc.

WARNING

People who fly should recognize that various types of risks are involved; and they should take all precautions to minimize them, since they cannot be eliminated entirely.

The propeller is a vital component of the aircraft. A mechanical failure of the propeller could cause a forced landing or create vibrations sufficiently severe to damage the aircraft, possibly causing it to become uncontrollable.

Propellers are subject to constant vibration stresses from the engine and airstream, which are added to high bending and centrifugal stresses.

Before a propeller is certified as being safe to operate on an airplane, an adequate margin of safety must be demonstrated. Even though every precaution is taken in the design and manufacture of a propeller, history has revealed rare instances of failures, particularly of the fatigue type.

It is essential that the propeller is properly maintained according to the recommended service procedures and a close watch is exercised to detect impending problems before they become serious. Any grease or oil leakage, loss of air pressure, unusual vibration, or unusual operation should be investigated and repaired, as it could be a warning that something serious is wrong.

For operators of uncertified or experimental aircraft an even greater level of vigilance is required in the maintenance and inspection of the propeller. Experimental installations often use propeller-engine combinations that have not been tested and approved. In these cases, the stress on the propeller and, therefore, its safety margin is unknown. Failure could be as severe as loss of propeller or propeller blades and cause loss of propeller control and/or loss of aircraft control.

Hartzell Propeller Inc. follows FAA regulations for propeller certification on certificated aircraft. Experimental aircraft may operate with unapproved engines or propellers or engine modifications to increase horsepower, such as unapproved crankshaft damper configurations or high compression pistons. These issues affect the vibration output of the engine and the stress levels on the propeller. Significant propeller life reduction and failure are real possibilities.

Frequent inspections are strongly recommended if operating with a non-certificated installation; however, these inspections may not guarantee propeller reliability, as a failing device may be hidden from the view of the inspector. Propeller overhaul is strongly recommended to accomplish periodic internal inspection.

Visually inspect metal blades for cracks. Inspect hubs, with particular emphasis on each blade arm for cracks. Eddy current equipment is recommended for hub inspection, since cracks are usually not apparent.

(This page is intentionally blank.)



REVISION 11 HIGHLIGHTS

- Revised the [Cover](#), Revision Highlights, and [List of Effective Pages](#), to match the manual revision
- INTRODUCTION
 - [Revised the Purpose section](#)
- INSTALLATION AND REMOVAL:
 - [Revised the Torque Table 3-1 for R flange propellers](#)
- MAINTENANCE PRACTICES
 - [Corrected typographical error in the Airworthy Damage section](#)
 - [Revised Approved Touch-up Paints Table 6-2](#)

(This page is intentionally blank.)

REVISIONS HIGHLIGHTS1. Introduction

A. General

This is a list of current revisions that have been issued against this manual. Please compare it to the RECORD OF REVISIONS page to ensure that all revisions have been added to the manual.

B. Components

- (1) Revision No. indicates the revisions incorporated in this manual.
- (2) Issue Date is the date of the revision.
- (3) Comments indicates the level of the revision.
 - (a) New Issue is a new manual distribution. The manual is distributed in its entirety. All the page revision dates are the same and no change bars are used.
 - (b) Reissue is a revision to an existing manual that includes major content and/or major format changes. The manual is distributed in its entirety. All the page revision dates are the same and no change bars are used.
 - (c) Major Revision is a revision to an existing manual that includes major content or minor content changes over a large portion of the manual. The manual is distributed in its entirety. All the page revision dates are the same, but change bars are used to indicate the changes incorporated in the latest revision of the manual.
 - (d) Minor Revision is a revision to an existing manual that includes minor content changes to the manual. Only the revised pages of the manual are distributed. Each page retains the date and the change bars associated with the last revision to that page.

<u>Revision No.</u>	<u>Issue Date</u>	<u>Comments</u>
Original	Mar/99	New Issue
Rev. 1	Mar/04	Minor Revision
Rev. 2	Jun/06	Minor Revision
Rev. 3	Jul/06	Minor Revision
Rev. 4	Dec/06	Minor Revision
Rev. 5	Oct/08	Minor Revision
Rev. 6	Nov/08	Minor Revision
Rev. 7	Oct/09	Minor Revision
Rev. 8	Jul/10	Minor Revision
Rev. 9	Jun/11	Minor Revision
Rev. 10	Oct/11	Minor Revision
Rev. 11	Dec/12	Minor Revision

SERVICE DOCUMENTS LIST

CAUTION 1: DO NOT USE OBSOLETE OR OUTDATED INFORMATION. PERFORM ALL INSPECTIONS OR WORK IN ACCORDANCE WITH THE MOST RECENT REVISION OF THE SERVICE DOCUMENT. INFORMATION CONTAINED IN A SERVICE DOCUMENT MAY BE SIGNIFICANTLY CHANGED FROM EARLIER REVISIONS. USE OF OBSOLETE INFORMATION MAY CREATE AN UNSAFE CONDITION THAT MAY RESULT IN DEATH, SERIOUS BODILY INJURY, AND/OR SUBSTANTIAL PROPERTY DAMAGE. REFER TO THE APPLICABLE SERVICE DOCUMENT INDEX FOR THE MOST RECENT REVISION LEVEL OF THE SERVICE DOCUMENT.

CAUTION 2: THE INFORMATION FOR THE DOCUMENTS LISTED INDICATES THE REVISION LEVEL AND DATE AT THE TIME THAT THE DOCUMENT WAS INITIALLY INCORPORATED INTO THIS MANUAL. INFORMATION CONTAINED IN A SERVICE DOCUMENT MAY BE SIGNIFICANTLY CHANGED FROM EARLIER REVISIONS. REFER TO THE APPLICABLE SERVICE DOCUMENT INDEX FOR THE MOST RECENT REVISION LEVEL OF THE SERVICE DOCUMENT.

Service Document Number	Incorporation Rev/Date
Service Bulletins:	
HC-SB-61-246	Rev. 2 Jun/06
HC-SB-61-246, R1	Rev. 10 Oct/11
Service Letters:	
HC-SL-61-194	Rev. 2 Jun/06
HC-SL-61-200	Rev. 2 Jun/06

SERVICE DOCUMENTS LIST

CAUTION 1: DO NOT USE OBSOLETE OR OUTDATED INFORMATION. PERFORM ALL INSPECTIONS OR WORK IN ACCORDANCE WITH THE MOST RECENT REVISION OF THE SERVICE DOCUMENT. INFORMATION CONTAINED IN A SERVICE DOCUMENT MAY BE SIGNIFICANTLY CHANGED FROM EARLIER REVISIONS. USE OF OBSOLETE INFORMATION MAY CREATE AN UNSAFE CONDITION THAT MAY RESULT IN DEATH, SERIOUS BODILY INJURY, AND/OR SUBSTANTIAL PROPERTY DAMAGE. REFER TO THE APPLICABLE SERVICE DOCUMENT INDEX FOR THE MOST RECENT REVISION LEVEL OF THE SERVICE DOCUMENT.

CAUTION 2: THE INFORMATION FOR THE DOCUMENTS LISTED INDICATES THE REVISION LEVEL AND DATE AT THE TIME THAT THE DOCUMENT WAS INITIALLY INCORPORATED INTO THIS MANUAL. INFORMATION CONTAINED IN A SERVICE DOCUMENT MAY BE SIGNIFICANTLY CHANGED FROM EARLIER REVISIONS. REFER TO THE APPLICABLE SERVICE DOCUMENT INDEX FOR THE MOST RECENT REVISION LEVEL OF THE SERVICE DOCUMENT.

Service Document Number	Incorporation Rev/Date

AIRWORTHINESS LIMITATIONS

1. Replacement Time (Life Limits)
 - A. The FAA establishes specific life limits for certain component parts, as well as the entire propeller. Such limits require replacement of the identified parts after a specified number of hours of use.
 - B. The following data summarizes all current information concerning Hartzell life limited parts as related to propeller models affected by this manual. These parts are not life limited on other installations; however, time accumulated toward life limit accrues when first operated on aircraft/engine/propeller combinations listed, and continues regardless of subsequent installations (which may or may not be life limited).
 - (1) The following list specifies life limits for blades only. Associated hub parts are not affected. Blade models shown are life limited only on the specified applications.

FAA APPROVED

by: _____

date: _____

OCT 15 2009

Manager, Chicago Aircraft Certification
Office,
ACE-115C
Federal Aviation Administration

AIRWORTHINESS LIMITATIONS

Aircraft/Engine/Propeller	Blade Life Limit
Aircraft: Mooney PFM Engine: Porsche Propeller: BHC-J2YF-1C/B7421	3,000 hours
Aircraft: Aviat Pitts S-2B Engine: Lycoming AEIO-540-D4A5 Propeller: HC-C3YR-1A/7690C	12,500 hours

FAA APPROVED

by:  _____

OCT 15 2009

date: _____

Manager, Chicago Aircraft Certification
Office,
ACE-115C
Federal Aviation Administration

AIRWORTHINESS LIMITATIONS

2. Periodic Inspections
 - A. Inspect the composite blade assembly, ()7690J installed on aircraft with the SMA SR305 engine, at intervals not greater than 500 flight hours, in accordance with Hartzell Service Bulletin HC-SB-61-266, Rev. 1.
 - B. Disassemble and inspect Hartzell propeller models HC-()3YR-1()/()7690J installed on aircraft with the SMA SR305 engine at an interval not greater than 500 flight hours in accordance with Hartzell Service Bulletin HC-SB-61-266, Rev. 1.
 - C. Disassemble and inspect Hartzell propeller models HC-()3YR-2()/()7690J installed on aircraft with the SMA SR305 engine at an interval not greater than 500 flight hours in accordance with Hartzell Service Bulletin HC-SB-61-266, Rev. 1.

FAA APPROVED

OCT 15 2009

by: _____

date: _____

Manager, Chicago Aircraft Certification
Office,
ACE-115C
Federal Aviation Administration

LIST OF EFFECTIVE PAGES

Chapter	Page	Revision	Date
Cover and Inside Cover		Rev. 11	Dec/12
Message	1 thru 4	Rev. 1	Mar/04
Revision Highlights	5 thru 8	Rev. 11	Dec/12
Record of Revisions	9 and 10	Rev. 1	Mar/04
Record of Temporary Revisions	11 and 12	Rev. 1	Mar/04
Service Documents List	13 and 14	Rev. 10	Oct/11
Airworthiness Limitations	15 thru 18	Rev. 7	Oct/09
List of Effective Pages	19 and 20	Rev. 11	Dec/12
Table of Contents	21 thru 24	Rev. 7	Oct/09
Table of Contents	25	Rev. 9	Jun/11
Table of Contents	26	Rev. 10	Oct/11
Table of Contents	27	Rev. 7	Oct/09
Table of Contents	28	Rev. 9	Jun/11
Table of Contents	29 and 30	Rev. 10	Oct/11
Introduction	1-1 thru 1-4	Rev. 11	Dec/12
Introduction	1-5	Rev. 9	Jun/11
Introduction	1-6 and 1-7	Rev. 7	Oct/09
Introduction	1-8 thru 1-16	Rev. 5	Oct/08
Description and Operation	2-1	Rev. 5	Oct/08
Description and Operation	2-2	Rev. 10	Oct/11
Description and Operation	2-3	Rev. 2	Jun/06
Description and Operation	2-4	Rev. 3	Jul/06
Description and Operation	2-4.1 thru 2-4.4	Rev. 9	Jun/11
Description and Operation	2-5	Rev. 5	Oct/08
Description and Operation	2-6	Rev. 3	Jul/06
Description and Operation	2-7 thru 2-11	Rev. 2	Jun/06
Description and Operation	2-12	Rev. 9	Jun/11
Description and Operation	2-13	Rev. 10	Oct/11
Description and Operation	2-14 thru 2-19	Rev. 2	Jun/06
Description and Operation	2-20 thru 2-22	Rev. 5	Oct/08
Installation and Removal	3-1 thru 3-3	Rev. 6	Nov/08
Installation and Removal	3-4	Rev. 5	Oct/08
Installation and Removal	3-5	Rev. 11	Dec/12
Installation and Removal	3-6 thru 3-8	Rev. 5	Oct/08
Installation and Removal	3-9 thru 3-34	Rev. 6	Nov/08
Testing and Troubleshooting	4-1 thru 4-14	Rev. 5	Oct/08
Inspection and Check	5-1 and 5-2	Rev. 5	Oct/08
Inspection and Check	5-3	Rev. 10	Oct/11

LIST OF EFFECTIVE PAGES

Chapter	Page	Revision	Date
Inspection and Check	5-4	Rev. 7	Oct/09
Inspection and Check	5-5 and 5-6	Rev. 5	Oct/08
Inspection and Check	5-7 and 5-8	Rev. 10	Oct/11
Inspection and Check	5-9 thru 5-26	Rev. 5	Oct/08
Maintenance Practices	6-1	Rev. 10	Oct/11
Maintenance Practices	6-2	Rev. 9	Jun/11
Maintenance Practices	6-3	Rev. 10	Oct/11
Maintenance Practices	6-4	Rev. 7	Oct/09
Maintenance Practices	6-5 thru 6-10	Rev. 5	Oct/08
Maintenance Practices	6-11	Rev. 9	Jun/11
Maintenance Practices	6-12	Rev. 5	Oct/08
Maintenance Practices	6-13	Rev. 9	Jun/11
Maintenance Practices	6-14 and 6-15	Rev. 5	Oct/08
Maintenance Practices	6-16 and 6-17	Rev. 10	Oct/11
Maintenance Practices	6-18 thru 6-20	Rev. 9	Jun/11
Maintenance Practices	6-21 thru 6-27	Rev. 5	Oct/08
Maintenance Practices	6-28 thru 6-32	Rev. 9	Jun/11
Maintenance Practices	6-32.1	Rev. 11	Dec/12
Maintenance Practices	6-32.2 and 6-32.3	Rev. 9	Jun/11
Maintenance Practices	6-32.4 and 6-32.5	Rev. 10	Oct/11
Maintenance Practices	6-32.6 thru 6-32.12	Rev. 9	Jun/11
Maintenance Practices	6-32.13 and 6-32.14	Rev. 10	Oct/11
Maintenance Practices	6-33 thru 6-36	Rev. 10	Oct/11
Maintenance Practices	6-37 and 6-38	Rev. 5	Oct/08
Maintenance Practices	6-39 and 6-40	Rev. 11	Dec/12
Maintenance Practices	6-41 and 6-42	Rev. 5	Oct/08
Maintenance Practices	6-42.1	Rev. 10	Oct/11
Maintenance Practices	6-42.2	Rev. 9	Jun/11
Maintenance Practices	6-43 thru 6-56	Rev. 5	Oct/08
Maintenance Practices	6-57	Rev. 7	Oct/09
Maintenance Practices	6-58	Rev. 10	Oct/11
Maintenance Practices	6-59 thru 6-62	Rev. 7	Oct/09
Anti-Ice and De-Ice Systems	7-1 thru 7-8	Rev. 5	Oct/08
Records	801 and 802	Rev. 10	Oct/11
Records	803 thru 812	Orig.	Mar/99
Records	813 thru 816	Rev. 2	Jun/06
Records	817 thru 822	Rev. 3	Jul/06
Records	823 thru 826	Rev. 10	Oct/11

TABLE OF CONTENTS

MESSAGE.....	1
REVISION HIGHLIGHTS	5
RECORD OF REVISIONS	9
RECORD OF TEMPORARY REVISIONS.....	11
SERVICE DOCUMENTS LIST	13
AIRWORTHINESS LIMITATIONS	15
LIST OF EFFECTIVE PAGES	19
TABLE OF CONTENTS.....	21
INTRODUCTION.....	1-1
1. Purpose.....	1-3
2. Airworthiness Limits	1-3
3. Airframe or Engine Modifications	1-4
4. Restrictions and Placards	1-5
5. General	1-5
A. Personnel Requirements	1-5
B. Maintenance Practices	1-5
C. Continued Airworthiness.....	1-7
6. Reference Publications	1-8
7. Definitions	1-9
8. Abbreviations	1-13
9. Hartzell Product Support.....	1-14
10. Warranty Service.....	1-14
11. Hartzell Recommended Facilities	1-15
DESCRIPTION AND OPERATION.....	2-1
1. Description of Propeller and Systems.....	2-3
A. System Overview.....	2-3
2. Functional Description of Constant Speed Propeller Types.....	2-5
A. ()HC-() ()Y() ()-1() with Composite Blades.....	2-5
B. Constant Speed, Feathering Propellers ()HC-() ()Y()-2..	2-7
C. Counterweighted, Aerobatic ()HC-() ()Y()-4()	2-11

TABLE OF CONTENTS, continued**DESCRIPTION AND OPERATION, continued**

3. Model Designation	2-12
A. Aluminum Hub Propeller Model Identification.....	2-12
B. Composite Blade Model Identification	2-13
4. Governors	2-15
A. Theory of Operation.....	2-15
B. Governor Types	2-17
C. Identification of Hartzell Governors	2-17
5. Accumulators	2-19
A. System Overview.....	2-19
6. Propeller Ice Protection Systems System.....	2-20
A. Propeller Anti-ice System	2-20
B. Propeller De-ice System.....	2-21

INSTALLATION AND REMOVAL..... 3-1

1. Tools, Consumables, and Expendables.....	3-3
A. Tooling	3-3
B. Consumables.....	3-3
C. Expendables.....	3-3
2. Pre-Installation	3-7
A. Inspection of Shipping Package	3-7
B. Uncrating	3-7
C. Inspection after Shipment.....	3-7
D. Reassembly of a Propeller Disassembled for Shipment ...	3-7
E. Air Charge Pressure Check (-2 Propellers).....	3-7
3. Spinner Pre-Installation.....	3-9
A. General.....	3-9
B. Installation of a Metal Spinner Bulkhead on a Propeller Hub	3-11
C. Installation of a Composite Spinner Bulkhead on a Propeller Hub	3-13
4. Propeller Installation	3-15
A. Flange Description.....	3-15
B. Installation of "F" Flange Propellers.....	3-17
C. Installation of "R" Flange Propellers	3-21

TABLE OF CONTENTS, continued**INSTALLATION AND REMOVAL, continued**

5. Spinner Installation	3-25
A. Single Piece Spinner Dome.....	3-25
B. Two-piece Spinner Dome (Procedure 1)	3-27
C. Two-Piece Spinner Dome (Procedure 2).....	3-29
6. Post-Installation Checks	3-30
7. Spinner Removal	3-30
A. Removal of Single Piece Spinner	3-30
B. Removal of Two-Piece Spinner	3-30
C. Hub Mounted Spinner Bulkhead Removal	3-30
D. Starter Ring Gear Spinner Adapter Removal	3-31
8. Propeller Removal	3-31
A. Removal of "F" Flange Propellers.....	3-31
B. Removal of "R" Flange Propellers	3-33

TESTING AND TROUBLESHOOTING 4-1

1. Operational Tests	4-3
A. Initial Run-Up.....	4-3
B. Static RPM Check	4-3
C. Post-Run Check	4-4
2. Propeller Ice Protection Systems.....	4-5
A. Electric De-Ice System	4-5
B. Anti-Ice System	4-5
3. Troubleshooting	4-6
A. Hunting and Surging.....	4-6
B. Engine Speed Varies with Flight Attitude (or Airspeed)	4-6
C. Loss of Propeller Control (-1 propellers only)	4-8
D. Loss of Propeller Control (-2 and -4 propellers)	4-8
E. Failure to Feather or Feathers Slowly (-2 propellers only)	4-9
F. Failure to Unfeather (-2 propellers only).....	4-9
G. Start Locks (Anti-feather Latches) Fail to Latch on Shutdown (-2 propellers only).....	4-10
H. Vibration	4-11
I. Propeller Overspeed.....	4-12
J. Overspeed Avoidance (Operational) for Propeller Models HC-() (2,3)Y() ()-1()	4-13

TABLE OF CONTENTS, continued**TESTING AND TROUBLESHOOTING, continued**

- K. Overspeed Avoidance (Mechanical Modification)
for Propeller Models HC-() (2,3)Y()(-1() 4-13
- L. Propeller Underspeed..... 4-14
- M. Oil or Grease Leakage 4-14

INSPECTION AND CHECK..... 5-1

- 1. Pre-Flight Checks 5-3
- 2. Operational Checks 5-5
- 3. Required Periodic Inspections and Maintenance..... 5-6
 - A. Periodic Inspections 5-6
 - B. Periodic Maintenance 5-8
 - C. Airworthiness Limitations 5-8
 - D. Overhaul Periods..... 5-9
- 4. Inspection Procedures 5-11
 - A. Blade Damage..... 5-11
 - B. Grease or Oil Leakage 5-11
 - C. Vibration 5-13
 - D. Tachometer Inspection 5-15
 - E. Blade Track..... 5-16
 - F. Loose Blades..... 5-17
 - G. Corrosion 5-18
 - H. Spinner Damage..... 5-18
 - I. Accumulator..... 5-18
 - J. Electric De-Ice System 5-18
 - K. Anti-ice System..... 5-18
- 5. Special Inspections 5-20
 - A. Overspeed/Overtorque 5-20
 - B. Lightning Strike..... 5-21
 - C. Foreign Object Strike/Ground Strike..... 5-23
 - D. Fire Damage or Heat Damage 5-25
- 6. Long Term Storage..... 5-25

MAINTENANCE PRACTICES..... 6-1

- 1. Cleaning..... 6-5
 - A. General Cleaning..... 6-5
 - B. Spinner Cleaning and Polishing 6-5

TABLE OF CONTENTS, continued**MAINTENANCE PRACTICES, continued**

2.	Lubrication	6-7
	A. Lubrication Intervals	6-7
	B. Lubrication Procedure	6-9
	C. Approved Lubricants.....	6-12
3.	Air Charge (-2 Propellers).....	6-13
	A. Charging the Propeller.....	6-13
4.	Composite Blades.....	6-14
	A. General Description.....	6-14
	B. Component Life and Service	6-18
	C. Personnel Requirements.....	6-20
	D. Determination of Repair.....	6-21
	E. Blade Inspection Requirements.....	6-24
	F. Coin-Tap Test	6-26
	G. Airworthy Damage.....	6-27
	H. Unairworthy Damage.....	6-33
	I. On Wing Blade Shank Inspection.....	6-35
	J. Lightning Strike Damage	6-37
	K. Minor Repair.....	6-39
5.	Painting of Composite Blades.....	6-40
	A. General.....	6-40
	B. Procedure	6-41
	C. Optional Removal of Leading Edge Paint for N7605() Blade	6-42.1
6.	Dynamic Balance	6-44
	A. Overview.....	6-44
	B. Inspection Procedures Before Balancing	6-45
	C. Modifying Spinner Bulkhead to Accommodate Dynamic Balance Weights.....	6-46
	D. Placement of Balance Weights for Dynamic Balance	6-47
7.	Propeller Low Pitch Setting.....	6-49
	A. Low Pitch Stop - All Propeller Models.....	6-49
	B. Max. RPM (Static) Low Pitch Stop Adjustment.....	6-51
8.	Propeller High Pitch Settings	6-53
	A. High Pitch (Min. RPM) Stop.....	6-53
9.	Start Lock Settings.....	6-53
	A. Start Lock Pitch Stop.....	6-53

TABLE OF CONTENTS, continued**MAINTENANCE PRACTICES, continued**

10. Accumulator Part Number Change	6-54
A. General.....	6-54
B. Material Information.....	6-55
C. Accomplishment Instructions.....	6-55
11. Propeller Ice Protection Systems.....	6-56
A. Electric De-ice System	6-56
B. Anti-ice System.....	6-56
12. Installation of Erosion Tape CM158	6-57
A. General.....	6-57
B. Materials Required	6-58
C. Installation Procedure.....	6-59

ANTI-ICE AND DE-ICE SYSTEMS 7-1

1. Introduction	7-3
A. Propeller De-ice System.....	7-3
B. Propeller Anti-ice System	7-3
2. System Description	7-4
A. De-ice System	7-4
B. Anti-ice System.....	7-5
3. De-ice System Functional Tests.....	7-6
4. Anti-ice System Functional Tests	7-6
5. De-ice and Anti-ice System Inspections.....	7-7
A. De-ice System Inspections.....	7-7
B. Anti-ice System Inspections	7-7
6. De-ice and Anti-ice System Troubleshooting	7-8
A. De-ice System Troubleshooting.....	7-8
B. Anti-ice System Troubleshooting.....	7-8

RECORDS.....801

1. Introduction	803
2. Record Keeping	803
A. Information to be Recorded.....	803
B. Blade Damage Repair Sheets	803
()7690E.....	804
B7421().....	807
7890().....	810
()7690().....	813
N()7893().....	817
N7605().....	820
N7605C().....	823

LIST OF FIGURES

-1 Series Constant Speed, Non-Counterweighted Propeller ()HC-() ()Y()-1() with Large Cylinder.....	Figure 2-1	2-4.2
-1 Series Constant Speed, Non-Counterweighted Propeller ()HC-() ()Y()-1() with Small Cylinder	Figure 2-1.1	2-4.3
-1N Series Constant Speed, Non-Counterweighted Propeller	Figure 2-1.2	2-4.4
Cutaway of -2 Series Constant Speed, Feathering Propeller ()HC-() ()Y()-2	Figure 2-2	2-6
Cutaway of -4 Series Constant Speed, Counterweighted Propeller	Figure 2-3	2-10
Governor in Onspeed Condition	Figure 2-4	2-14
Governor in Underspeed Condition	Figure 2-5	2-14
Governor in Overspeed Condition	Figure 2-6	2-14
Synchronizer/Synchrophaser Governor	Figure 2-7	2-16
Governor/Accumulator System.....	Figure 2-8	2-18
Determining Torque Value When Using Torquing Adapter	Figure 3-1	3-4
Diagram of Torquing Sequence for Propeller Mounting Hardware.....	Figure 3-2	3-6
Hub Clamping Bolt Location	Figure 3-3	3-8
Metal Bulkhead and Spinner Mounting (Hub Mounted Spinner)	Figure 3-4	3-10
Composite Bulkhead and Spinner Mounting (Hub Mounted Spinner)	Figure 3-5	3-12
F Flange Propeller Mounting	Figure 3-6	3-16
R Flange Propeller Mounting.....	Figure 3-7	3-20
Two-Piece Spinner Mounting (Procedure 1)...	Figure 3-8	3-26
Two-Piece Spinner Mounting (Procedure 2)...	Figure 3-9	3-28

LIST OF FIGURES, continued

Spinner Dome-to-Bulkhead Mounting Hole Alignment	Figure 3-10	3-28
Checking Blade Track.....	Figure 5-1	5-16
Blade Play	Figure 5-2.....	5-17
Reciprocating Engine Overspeed Limits	Figure 5-3.....	5-19
Grease Fitting and Air Charge Valve Location	Figure 6-1	6-6
Lubrication Fitting	Figure 6-2.....	6-8
Lubrication Label	Figure 6-3.....	6-9
Section of Typical Composite Blade (C)7690(E,J), B7421, or 7890K.....	Figure 6-4	6-14
Basic Components of a Composite Blade (C)7690(E,J), B7421, or 7890K.....	Figure 6-5.....	6-15
Section of Typical N-shank Composite Blade	Figure 6-6.....	6-16
Basic Components of an N-shank Composite Blade	Figure 6-7	6-17
Determination of Repair Flow Chart	Figure 6-8.....	6-21
Coin-Tap Test to Check for Debonds and Delaminations.....	Figure 6-9.....	6-26
Interpretation of Erosion Shield Damage.....	Figure 6-10.....	6-28
Missing Portion of the Erosion Shield (Trailing Edge).....	Figure 6-11	6-29
Acceptable Erosion Shield Damage and Unacceptable Crack Locations.....	Figure 6-12.....	6-31
Debonds Exceeding the Allowable Limits.....	Figure 6-13.....	6-31
Blade Regions - All Except N-shank Blades..	Figure 6-13.1	6-32
Blade Regions - N-shank Blades Only	Figure 6-13.2... ..	6-32.4
N-shank Kevlar®/Carbon Hybrid Blade Limits..	Figure 6-13.3... ..	6-32.7
Crushed and Cracked Trailing Edge.....	Figure 6-14.....	6-33

LIST OF FIGURES, continued

Inspection Areas for Counterweighted and Non-counterweighted Blades	Figure 6-15.....	6-34
Evidence of Lightning Strike Damage to Composite Blade	Figure 6-16.....	6-36
Removal of the Leading Edge Paint for Blade N7605	Figure 6-16.1 ...	6-42.1
Low Pitch Stop Adjustment (-1, -4).....	Figure 6-17.....	6-50
Low Pitch Stop Adjustment (-2).....	Figure 6-18.....	6-50
Accumulator Part Number Change.....	Figure 6-19.....	6-54

LIST OF TABLES

Blade Type and Blade Model Designations... Table 2-1	2-13	
Torque Table	Table 3-1	3-5
Metal Spinner Bulkhead Mounting Hardware	Table 3-2	3-11
Composite Spinner Bulkhead Mounting Hardware	Table 3-3	3-13
Propeller/Engine Flange O-rings and Hardware	Table 3-4	3-14
Spinner Dome and Spinner Cap Mounting Hardware	Table 3-5	3-24
Air Charge Pressure	Table 6-1	6-13
Approved Touch-up Paints	Table 6-2	6-40
Erosion Tape.....	Table 6-3	6-58

(This page is intentionally blank.)

INTRODUCTION - CONTENTS

1. Purpose	1-3
2. Airworthiness Limitations.....	1-4
3. Airframe or Engine Modifications	1-4
4. Restrictions and Placards.....	1-5
5. General.....	1-5
A. Personnel Requirements	1-5
B. Maintenance Practices	1-5
C. Continued Airworthiness.....	1-7
6. Reference Publications	1-8
7. Definitions.....	1-9
8. Abbreviations.....	1-13
9. Hartzell Product Support	1-14
10. Warranty Service	1-14
11. Hartzell Recommended Facilities.....	1-15

(This page is intentionally blank.)

1. Purpose

- A. This manual has been reviewed and accepted by the FAA. Additionally, the Airworthiness Limitations Section of this manual has been approved by the FAA.

CAUTION: KEEP THIS MANUAL WITH THE PROPELLER OR THE AIRCRAFT UPON WHICH IT IS INSTALLED AT ALL TIMES. THE LOG BOOK RECORD WITHIN THIS MANUAL MUST BE MAINTAINED, RETAINED CONCURRENTLY, AND BECOME A PART OF THE AIRCRAFT AND ENGINE SERVICE RECORDS.

- B. This manual supports Hartzell Propeller Inc. Constant Speed and Constant Speed Feathering Compact series propellers with composite blades.

(1) The purpose of this manual is to enable qualified personnel to install, operate, and maintain a Hartzell Propeller Inc. Constant Speed or Constant Speed Feathering Propeller. Separate manuals are available concerning overhaul procedures and specifications for the propeller.

(2) This manual includes several design types.

- (a) Sample propeller and blade model designations within each design are included in the Description and Operation chapter of this manual.

1 Parentheses shown in the propeller model designations in this or other Hartzell Propeller Inc. publications indicate letter(s) and/or number(s) that may or may not be present because of different configurations permitted on the various aircraft installations.

2 Definitions of propeller model designations and further details of letters that may be present are shown in the Description and Operation chapter of this manual.

- (b) All propeller models included in this manual use composite propeller blades. Propellers that use aluminum blades are supported by Hartzell Propeller Inc. Owner's Manual 115N (61-00-15).

2. Airworthiness Limitations
 - A. Refer to the Airworthiness Limitations chapter of this manual for Airworthiness Limits information.
3. Airframe or Engine Modifications
 - A. Propellers are approved vibrationwise on airframe and engine combinations based on tests or analysis of similar installations. This data has demonstrated that propeller stress levels are affected by airframe configuration, airspeed, weight, power, engine configuration and flight maneuvers. Aircraft modifications that can affect propeller stress include, but are not limited to: aerodynamic changes ahead of or behind the propeller, realignment of the thrust axis, increasing airspeed limits, decreasing stall speed, increasing or decreasing weight limits (less significant on piston engines), the addition of approved flight maneuvers (utility and aerobatic).
 - B. Engine modifications can also affect the propeller. The two primary categories of engine modifications are those that affect structure and those that affect power. An example of a structural engine modification is the alteration of the crankshaft or damper of a piston engine. Any change to the weight, stiffness or tuning of rotating components could result in a potentially dangerous resonant condition that is not detectable by the pilot. Most common engine modifications affect the power during some phase of operation. Some increase the maximum power output, while others improve the power available during hot and high operation (flat rating) or at off-peak conditions. Examples of such engine modifications include, but are not limited to: changes to the compressor, power turbine or hot section of a turboprop engine; and on piston engines, the addition or alteration of a turbocharger or turbonormalizer, increased compression ratio, increased RPM, altered ignition timing, electronic ignition, full authority digital electronic controls (FADEC), or tuned induction or exhaust.
 - C. All such modifications must be reviewed and approved by the propeller manufacturer before obtaining approval on the aircraft.

4. Restrictions and Placards

- A. The propellers included in this manual may have a restricted operating range that requires a cockpit placard.
- (1) The restrictions, if present, will vary depending on the propeller, blade, engine, and/or aircraft model.
 - (2) Review the propeller and aircraft type certificate data sheet (TCDS), Pilot Operating Handbook (POH), and any applicable Airworthiness Directives for specific information.

5. General**A. Personnel Requirements****(1) Inspection, Repair, and Overhaul**

- (a) Compliance to the applicable regulatory requirements established by the Federal Aviation Administration (FAA) is mandatory for anyone performing or accepting responsibility for any inspection and/or repair and/or overhaul of any Hartzell Propeller Inc. product.
- (b) Personnel performing maintenance are expected to have sufficient training and certifications (when required by the applicable Aviation Authority) to accomplish the work required in a safe and airworthy manner.

B. Maintenance Practices

- (1) The propeller and its components are highly vulnerable to damage when they are removed from the engine. Properly protect all components until they are reinstalled on the engine.
- (2) Never attempt to move the aircraft by pulling on the propeller.
- (3) Use only the approved consumables, e.g., solvents, lubricants, etc.
- (4) Observe applicable torque values during maintenance.
- (5) Approved paint must be applied to all composite blades. For information concerning the application of paint, refer to the Maintenance Practices chapter of this manual. Operation of blades without the specified finishes is not permitted.

- (6) Before installing the propeller on the engine, the propeller must be static balanced. New propellers are statically balanced at Hartzell. Overhauled propellers must be statically balanced by the overhaul facility before return to service.
 - (a) Dynamic balance is recommended, but may be accomplished at the discretion of the operator, unless specifically required by the airframe or engine manufacturer.
 - 1 Perform dynamic balancing in accordance with the Maintenance Practices chapter of this manual.
 - 2 Additional procedures may be found in the aircraft maintenance manual.
- (7) As necessary, use a soft, non-graphite pencil or crayon to make identifying marks on components.
- (8) As applicable, follow military standard NASM33540 for safety-wiring and cotter pinning general practices. Use 0.032 (0.81 mm) safety wire unless otherwise indicated.

CAUTION: DO NOT USE OBSOLETE OR OUTDATED INFORMATION. PERFORM ALL INSPECTIONS OR WORK IN ACCORDANCE WITH THE MOST RECENT REVISION OF THIS MANUAL. INFORMATION CONTAINED IN THIS MANUAL MAY BE SIGNIFICANTLY CHANGED FROM EARLIER REVISIONS. USE OF OBSOLETE INFORMATION MAY RESULT IN DEATH, SERIOUS BODILY INJURY, AND/OR SUBSTANTIAL PROPERTY DAMAGE. FOR THE MOST RECENT REVISION LEVEL OF THIS MANUAL, REFER TO THE HARTZELL WEBSITE AT WWW.HARTZELLPROP.COM.

- (9) The information in this manual revision supersedes data in all previously published revisions of this manual.

- (10) Refer to the airframe manufacturer's manuals in addition to the information in this manual because of possible special requirements for specific aircraft applications.
- (11) If the propeller is equipped with an ice protection system that uses components supplied by Hartzell Propeller Inc., applicable instructions and technical information for the components supplied by Hartzell can be found in the following publications available on the Hartzell website at www.hartzellprop.com:
 - (a) Manual 180 (30-61-80) - Propeller Ice Protection System Manual
 - (b) Manual 181 (30-60-81) - Propeller Ice Protection System Component Maintenance Manual
 - (c) Manual 182 (61-12-82) - Propeller Electrical De-Ice Boot Removal and Installation Manual
 - (d) Manual 183 (61-12-83) - Propeller Anti-Icing Boot Removal and Installation Manual
- (12) Propeller ice protection system components not supplied by Hartzell Propeller Inc. are controlled by the applicable TC or STC holder's Instructions for Continued Airworthiness (ICA).

C. Continued Airworthiness

- (1) Operators are urged to stay informed of Airworthiness information using Hartzell Service Bulletins and Service Letters that are available from Hartzell distributors, or from the Hartzell factory by subscription. Selected information is also available on the Hartzell Propeller Inc. website at www.hartzellprop.com.

6. Reference Publications

The following publications are referenced within this manual:

Hartzell Manual 113B (61-10-13) - Compact and Lightweight Compact Non-Feathering (-1) and Aerobatic (-4) Propeller Overhaul and Maintenance Manual.

Hartzell Manual 117D (61-10-17) - Compact Constant Speed and Feathering Propeller Overhaul and Maintenance Manual.

Hartzell Manual 127 (61-16-27) - Spinner Assembly Maintenance Manual

Hartzell Manual 130B (61-23-30) - Governor Overhaul Manual

Hartzell Manual 135F (61-13-35) - Composite Blade Maintenance Manual.

Hartzell Manual No. 159 (61-02-59) - Application Guide - Also available on the Hartzell Propeller Inc. website at www.hartzellprop.com

Hartzell Manual 165A (61-00-65) - Illustrated Tool and Equipment Manual

Hartzell Manual No. 180 (30-61-80) - Propeller Ice Protection System Manual - Also available on the Hartzell website at www.hartzellprop.com

Hartzell Manual No. 181 (30-60-81) - Propeller Ice Protection System Component Maintenance Manual - Also available on the Hartzell website at www.hartzellprop.com

Hartzell Manual No. 182 (61-12-82) - Propeller Electrical De-ice Boot Removal and Installation Manual - Also available on the Hartzell website at www.hartzellprop.com

Hartzell Manual No. 183 (61-12-83) - Propeller Anti-icing Boot Removal and Installation Manual - Also available on the Hartzell website at www.hartzellprop.com

Hartzell Manual No. 202A (61-01-02) - Standard Practices Manual, Volumes 1 through 11

Hartzell Service Letter HC-SL-61-61Y - Overhaul Periods and Service Life Limits for Hartzell Propellers, Governors, and Propeller Damper Assemblies - Also available on the Hartzell Propeller Inc. website at www.hartzellprop.com

7. Definitions

A basic understanding of the following terms will assist in maintaining and operating Hartzell propeller systems.

<u>Term</u>	<u>Definition</u>
Annealed	Softening of material due to overexposure to heat.
Blade Angle	Measurement of blade airfoil location described as the angle between the blade airfoil and the surface described by propeller rotation.
Brinelling.	A depression caused by failure of the material in compression.
Chord	A straight line between the leading and trailing edges of an airfoil.
Composite Material.	Kevlar® (yellow) or graphite (black) fibers bound together with or encapsulated within an epoxy resin.
Constant Force	A force which is always present in some degree when the propeller is operating.
Constant Speed	A propeller system which employs a governing device to maintain a selected engine RPM.
Corrosion	Gradual material removal or deterioration due to chemical action.
Crack	Irregularly shaped separation within a material, sometimes visible as a narrow opening at the surface.
Debond.	Separation of two materials that were originally bonded together in a separate operation.
Delamination.	Internal separation of the layers of composite material.



<u>Term</u>	<u>Definition</u>
Depression	Surface area where the material has been compressed but not removed.
Distortion	Alteration of the original shape or size of a component
Erosion	Gradual wearing away or deterioration due to action of the elements.
Exposure	Material open to action of the elements.
Feathering	A propeller with blades that may be rotated parallel to the relative wind, thus reducing aerodynamic drag.
Gouge.	Surface area where material has been removed
Horizontal Balance	Balance between the blade tip and the center of the hub.
Impact Damage	Damage that occurs when the propeller blade or hub assembly strikes, or is struck by, an object while in flight or on the ground.
Nick	Removal of paint and possibly a small amount of material.
Onspeed.	Condition in which the RPM selected by the pilot through the propeller control lever and the actual engine (propeller) RPM are equal.
Overhaul.	The periodic disassembly, inspection, repair, refinish, and reassembly of a propeller assembly.

<u>Term</u>	<u>Definition</u>
Overspeed	Condition in which the RPM of the propeller or engine exceeds predetermined maximum limits; the condition in which the engine (propeller) RPM is higher than the RPM selected by the pilot through the propeller control lever.
Overspeed Damage . . .	Damage that occurs when the propeller hub assembly rotates at a speed greater than the maximum limit for which it is designed.
Pitch	Same as "Blade Angle".
Pitting	Formation of a number of small, irregularly shaped cavities in surface material caused by corrosion or wear.
Porosity.	An aggregation of microvoids. See "voids".
Scratch	See "Nick".
Single Acting.	Hydraulically actuated propeller which utilizes a single oil supply for pitch control.
Split.	Delamination of blade extending to the blade surface, normally found near the trailing edge or tip.
Synchronizing	Adjusting the RPM of all the propellers of a multi-engine aircraft to the same RPM.
Synchrophasing	A form of propeller sychronization in which not only the RPM of the engines (propellers) are held constant, but also the position of the propellers in relation to each other.



<u>Term</u>	<u>Definition</u>
Underspeed	The condition in which the actual engine (propeller) RPM is lower than the RPM selected by the pilot through the propeller control lever
Vertical Balance	Balance between the leading and trailing edges of a two-blade propeller with the blades positioned vertically.
Variable Force	A force which may be applied or removed during propeller operation.
Voids.	Air or gas that has been trapped and cured into a laminate.
Windmilling	The rotation of an aircraft propeller caused by air flowing through it while the engine is not producing power.



8. Abbreviations

<u>Abbreviation</u>	<u>Term</u>
AMM	Aircraft Maintenance Manual
AN	Air Force-Navy (or Army-Navy)
AOG	Aircraft on Ground
FAA	Federal Aviation Administration
Ft-Lb	Foot-Pound
ICA	Instructions for Continued Airworthiness
ID	Inside Diameter
In-Lb	Inch-Pound
IPS	Inches Per Second
kPa	Kilopascals
Lbs	Pounds
MIL-X-XXX	Military Specification
MPI	Major Periodic Inspection
MS	Military Standard
NAS	National Aerospace Standards
NASM	National Aerospace Standards, Military
N•m	Newton-Meters
OD	Outside Diameter
POH	Pilot's Operating Handbook
PSI	Pounds per Square Inch
RPM	Revolutions per Minute
STC	Supplemental Type Certificate
TBO	Time Between Overhaul
TC	Type Certificate
TSN	Time Since New
TSO	Time Since Overhaul

NOTE: TSN/TSO is considered as the time accumulated between rotation and landing, i.e., flight time.

9. Hartzell Product Support

Hartzell Propeller is ready to assist you with questions concerning your propeller system. Hartzell product support may be reached during business hours (8:00 am through 5:00 pm, United States Eastern Time) at (937) 778-4379 or at (800) 942-7767, toll free from the United States and Canada. Hartzell Product Support can also be reached by fax at (937) 778-4391, and by e-mail at techsupport@hartzellprop.com.

After business hours, you may leave a message on our 24 hour product support line at (937) 778-4376 or at (800) 942-7767, toll free from the United States and Canada. A technical representative will contact you during normal business hours. Urgent AOG support is also available 24 hours per day, seven days per week via this message service.

Additional information is available on our website at www.hartzellprop.com

NOTE: When calling from outside the United States, dial (001) before dialing the above telephone numbers.

10. Warranty Service

If you believe you have a warranty claim, it is necessary to contact Hartzell's Warranty Administrator. Hartzell's Warranty Administrator will provide a blank *Warranty Application* form. It is necessary to complete this form and return it to the Warranty Administrator for evaluation **before proceeding with repair or inspection work**. Upon receipt of this form, the Warranty Administrator will provide instructions on how to proceed. Hartzell Warranty may be reached during business hours (8:00 a.m. through 5:00 p.m., United States Eastern Time) at 778-4379, or toll free from the United States and Canada at (800) 942-7767. Hartzell Warranty Administration can also be reached by fax, at (937) 778-4391, or by e-mail at warranty@hartzellprop.com.

NOTE: When calling from outside the United States, dial (001) before dialing the above telephone numbers.

11. Hartzell Recommended Facilities

- A. Hartzell Propeller Inc. recommends using Hartzell approved distributors and repair facilities for the purchase, repair and overhaul of Hartzell propeller assemblies or components.
- B. Information about the Hartzell worldwide network of aftermarket distributors and approved repair facilities is available on the Hartzell Propeller Inc. website at www.hartzellprop.com.

(This page is intentionally blank.)

DESCRIPTION AND OPERATION - CONTENTS

- 1. Description of Propeller and Systems 2-3
 - A. System Overview 2-3
- 2. Functional Description of Constant Speed Propeller Types ... 2-5
 - A. ()HC-()()Y() ()-1() with Composite Blades 2-5
 - B. Constant Speed, Feathering Propellers ()HC-()()Y()-2 .. 2-7
 - C. Counterweighted, Aerobatic ()HC-()()Y()-4() 2-11
- 3. Model Designation 2-12
 - A. Aluminum Hub Propeller Model Identification 2-12
 - B. Composite Blade Model Identification 2-13
- 4. Governors 2-15
 - A. Theory of Operation 2-15
 - B. Governor Types 2-17
 - C. Identification of Hartzell Governors 2-17
- 5. Accumulators 2-19
 - A. System Overview 2-19
- 6. Propeller Ice Protection Systems 2-20
 - A. Propeller Anti-ice System 2-20
 - B. Propeller De-ice System 2-21

LIST OF FIGURES

-1 Series Constant Speed, Non-Counterweighted Propeller ()HC-()Y()-1() with Large Cylinder.....	Figure 2-1	2-4.2
-1 Series Constant Speed, Non-Counterweighted Propeller ()HC-()Y()-1() with Small Cylinder.....	Figure 2-1.1	2-4.3
-1N Series Constant Speed, Non-Counterweighted Propeller	Figure 2-1.2	2-4.4
Cutaway of -2 Series Constant Speed, Feathering Propeller ()HC-()Y()-2	Figure 2-2	2-6
Cutaway of -4 Series Constant Speed, Counterweighted Propeller	Figure 2-3	2-10
Governor in Onspeed Condition	Figure 2-4	2-14
Governor in Underspeed Condition	Figure 2-5	2-14
Governor in Overspeed Condition	Figure 2-6	2-14
Synchronizer/Synchrophaser Governor	Figure 2-7	2-16
Governor/Accumulator System.....	Figure 2-8	2-18

LIST OF TABLES

Blade Type and Blade Model Designations...	Table 2-1	2-13
--	---------------------------------	------

1. Description of Propeller and Systems**A. System Overview**

The propellers covered in this manual are constant speed, single-acting, hydraulically actuated propellers. These propellers are designed for use with reciprocating engines.

A constant speed propeller system is controlled by an engine speed sensing device (governor) to maintain a constant engine/propeller RPM by changing blade angle.

The governor uses an internal pump that is driven by the engine. This pump increases engine oil pressure for supply to the propeller. Engine speed sensing hardware within the governor controls the supply of oil to the propeller, supplying or draining oil as appropriate to maintain constant engine speed.

Propeller blade angle change is actuated by a hydraulic piston/cylinder combination mounted on the forward end of the propeller hub. The linear motion of the hydraulic piston is transmitted to each blade through a pitch change rod and a fork. A pitch change knob, located at the base of the blade, connects the blade to the fork. Each blade root is supported in the hub by a retention bearing. The retention bearing holds the blade firmly in the hub, but also allows the blade angle to change.

Propeller forces, consisting of: 1) mechanical spring action, 2) counterweight centrifugal twisting moment, 3) centrifugal and aerodynamic twisting moment of the blades, and 4) an air charge on some propellers, in various combinations, are constantly present while the propeller is operating. The summation of these forces is opposed by a variable hydraulic force (oil pressure from the engine driven governor). Oil pressure is metered by the governor to oppose these constant forces and maintain a constant engine RPM.

Oil under pressure from the engine-driven governor is supplied to the hydraulic cylinder through the pitch change rod. Increasing or decreasing the oil volume within the hydraulic cylinder either increases blade angle to reduce engine RPM, or reduces blade angle to increase engine RPM. By changing the blade angle, the governor maintains constant engine RPM (within limits), independent of the throttle setting.

If oil pressure is lost at any time, the summation of propeller forces, which is in direct opposition to the lost variable hydraulic force, either increases or reduces blade angle, depending upon propeller model.

(This page is intentionally blank.)

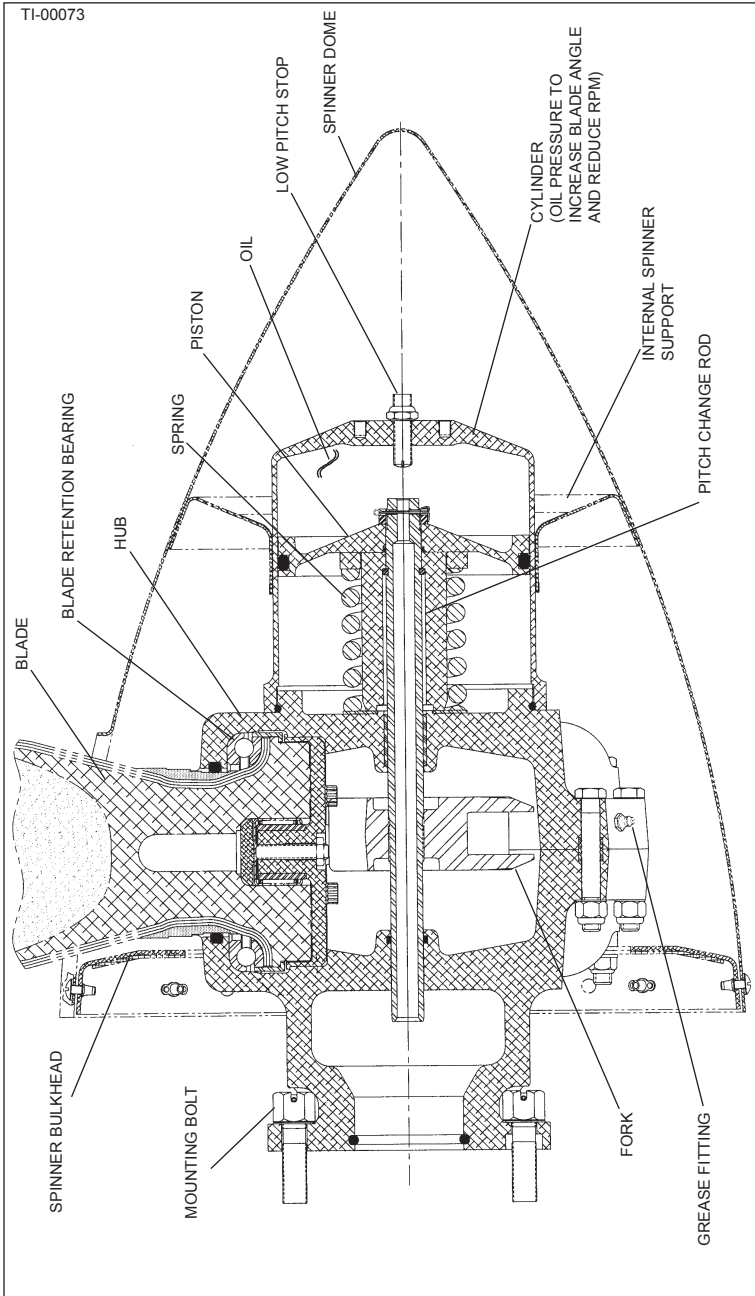

**-1 Series Constant Speed, Non-Counterweighted Propeller (JHC-(-)Y(-)-1(-)) with Large Cylinder
Figure 2-1**

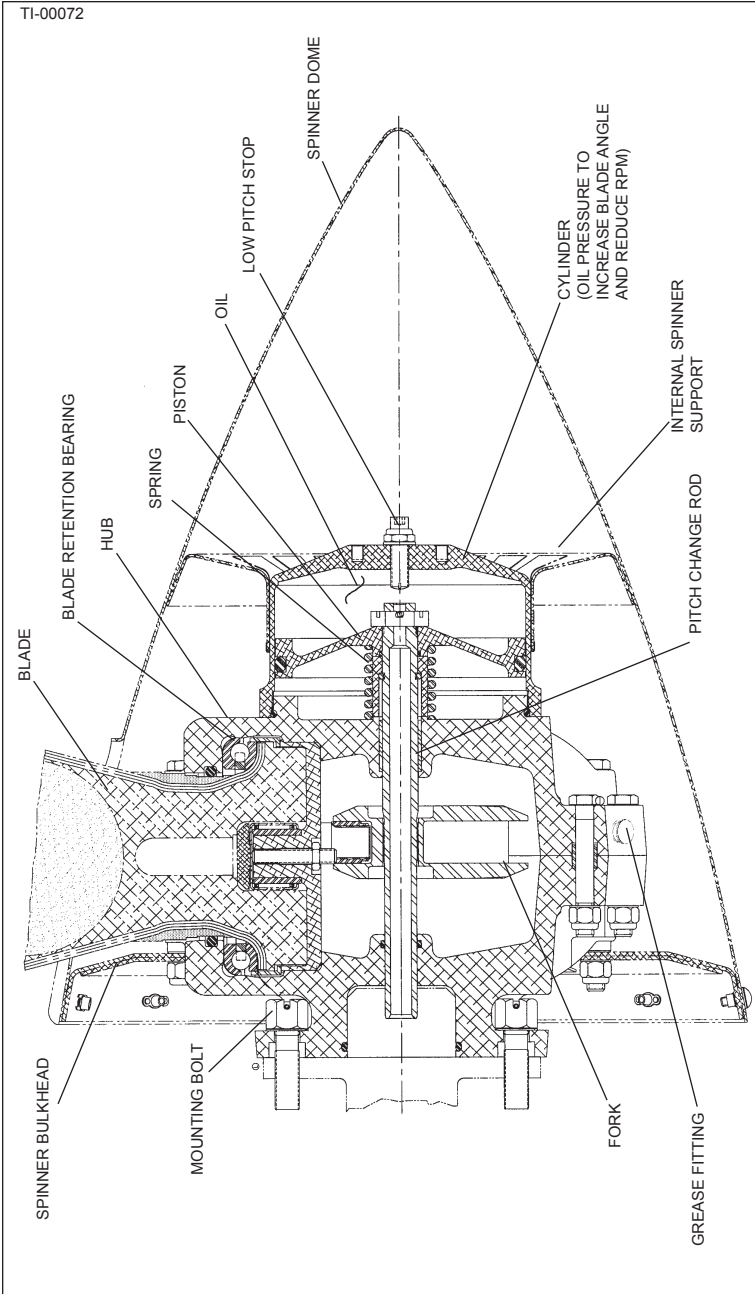

**-1 Series Constant Speed, Non-Counterweighted Propeller ()HC-()Y(-)-1() with Small Cylinder
Figure 2-1.1**

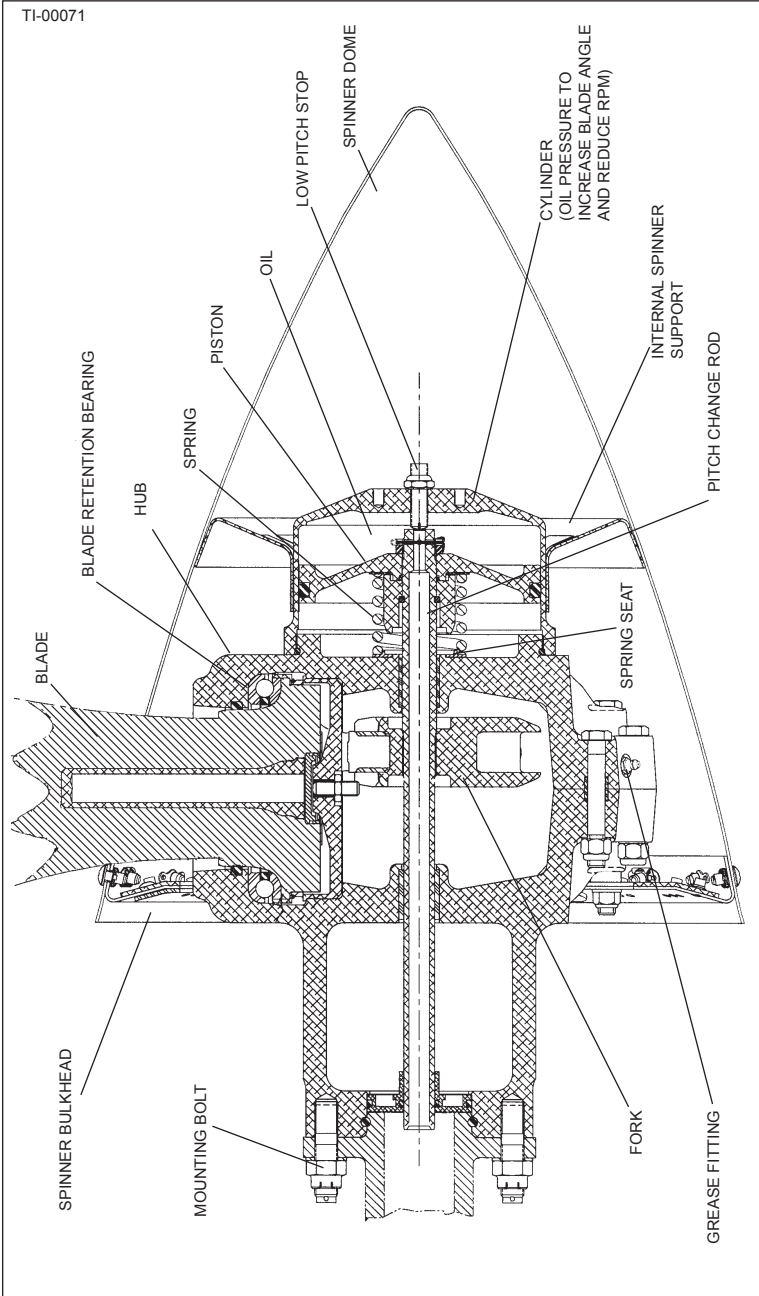

-1N Series Constant Speed, Non-Counterweighted Propeller
Figure 2-1.2

2. Functional Description of Constant Speed Propeller Types**A. ()HC-()Y()(-1() with Composite Blades**

These propeller model series (Figures 2-1, 2-1.1 and 2-1.2) are constant speed, non-counterweighted propellers.

The propellers are capable of blade angles between a low positive pitch (low pitch) and high positive pitch (high pitch). These propellers are sometimes used in aerobatic applications.

Centrifugal twisting moment acting on the blades moves the blades to a low blade angle (low pitch) to increase RPM. Since the centrifugal twisting moment is only present when the propeller is rotating, a mechanical spring is installed within the propeller to assist movement of the blades to a lower pitch position as RPM decays, and to reduce the propeller pitch to the low pitch stop when the propeller is static. With the blades at low pitch, the load on the starter when starting the engine is reduced significantly.

Oil pressure opposes the spring and centrifugal twisting moment to move the blades to a high blade angle (high pitch), reducing engine RPM.

If oil pressure is lost at any time, the propeller will move to low pitch. This occurs because the spring and blade centrifugal twisting moment are no longer opposed by hydraulic oil pressure. The propeller will then reduce blade pitch to the low pitch stop.

TI-00070

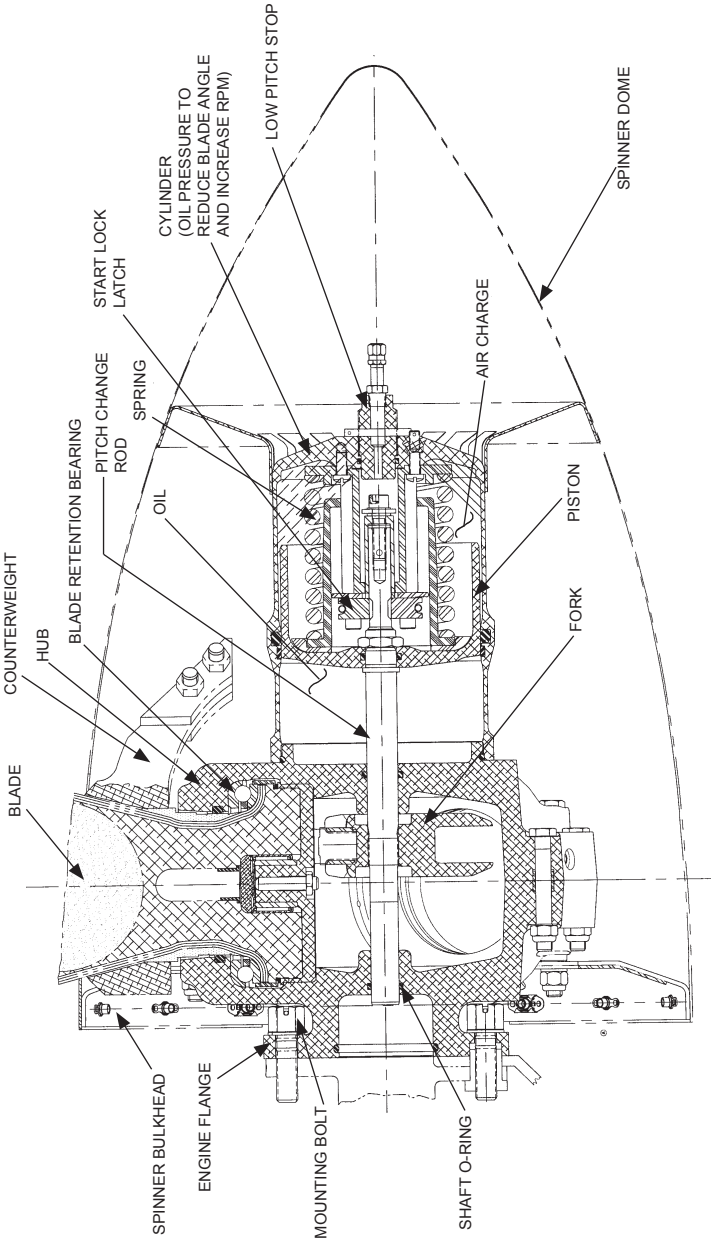

Cutaway of -2 Series Constant Speed, Feathering Propeller ()HC-()Y()-2
Figure 2-2

- B. Constant Speed, Feathering Propellers ()HC-()Y(-)2
Refer to Figure 2-2. The -2 Series propellers are constant speed propellers that use an air charge, spring, and counterweights (if installed) to move the blades to high pitch/feather position. Blade centrifugal twisting moment acts to move the blades to low pitch, but the air charge, spring, and counterweights overcome this force. Oil pressure against a propeller mounted hydraulic piston opposes the counterweight, spring, and air charge forces to move the blades to low blade angle (low pitch).

The action of the air charge, spring, and counterweights tends to move the blades to a higher blade angle (high pitch), reducing engine RPM. Oil pressure toward low pitch increases engine RPM.

If oil pressure is lost during operation, the propeller will feather. Feathering occurs because the air charge, spring, and blade counterweights are no longer opposed by hydraulic oil pressure. The air charge, spring and blade counterweights are then free to increase blade pitch to the feathering (high pitch) stop.

Normal in-flight feathering of these propellers is accomplished when the pilot retards the propeller pitch control past the feather detent. This allows control oil to drain from the cylinder and return to the engine sump. The engine can then be shut down.

Normal in-flight unfeathering is accomplished when the pilot positions the propeller pitch control into the normal flight (governing) range and an engine restart is attempted.

Some aircraft are equipped with a hydraulic accumulator, which stores a supply of oil under pressure. This oil supply is released to unfeather the propeller during an in-flight engine restart. Pressurized oil is directed to the propeller, resulting in blade angle decrease. The propeller begins to windmill, and engine restart is possible.

When the engine is stopped on the ground, it is undesirable to feather the propeller, as the high blade angle prevents the engine from starting. To prevent feathering during normal engine shutdown on the ground, the propeller incorporates spring energized latches. If propeller rotation is approximately 800 RPM or above, the latches are disengaged by centrifugal force acting on the latches to compress the springs. When RPM drops below 800 RPM (and blade angle is typically within 7 degrees of the low pitch stop), the springs overcome the latch weight centrifugal force and move the latches to engage the high pitch stops, preventing blade angle movement to feather during normal engine shutdown.

(This page is intentionally blank.)

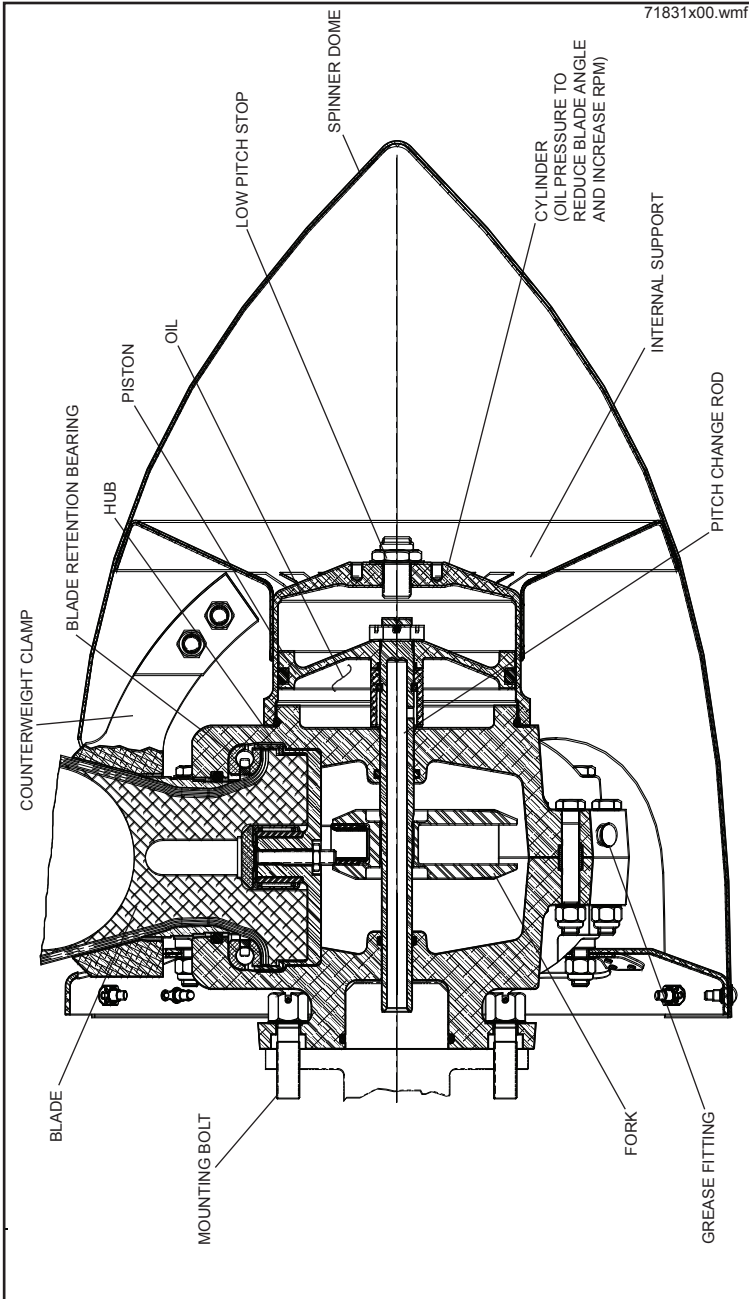

Cutaway of -4 Series Constant Speed, Counterweighted Propeller
Figure 2-3

C. Counterweighted, Aerobatic ()HC-()()Y()-4()

These propeller model series (Figure 2-3) are constant speed propellers with blade mounted counterweights. The propellers are capable of blade angles between a low positive pitch (low pitch) and high positive pitch (high pitch). These propellers are generally used in aerobatic applications.

The blade centrifugal twisting moment acts to move the blades to low blade angle (low pitch), but the counterweights are large enough to neutralize this force and produce a net increase in blade angle. Oil pressure against a propeller mounted hydraulic piston opposes the counterweight forces to move the blades to low pitch.

The action of the counterweights tends to move the blades to a high blade angle (high pitch), reducing engine RPM. Oil pressure toward low pitch increases engine RPM.

If oil pressure is lost at any time, the propeller will move to high pitch to avoid overspeeding. Movement to high pitch occurs because the blade counterweights are no longer opposed by hydraulic oil pressure. The blade counterweights are then free to increase blade pitch toward the high pitch stop.

3. Model Designation

The following pages illustrate sample model designations for Hartzell compact propeller hubs and blades.

A. Aluminum Hub Propeller Model Identification

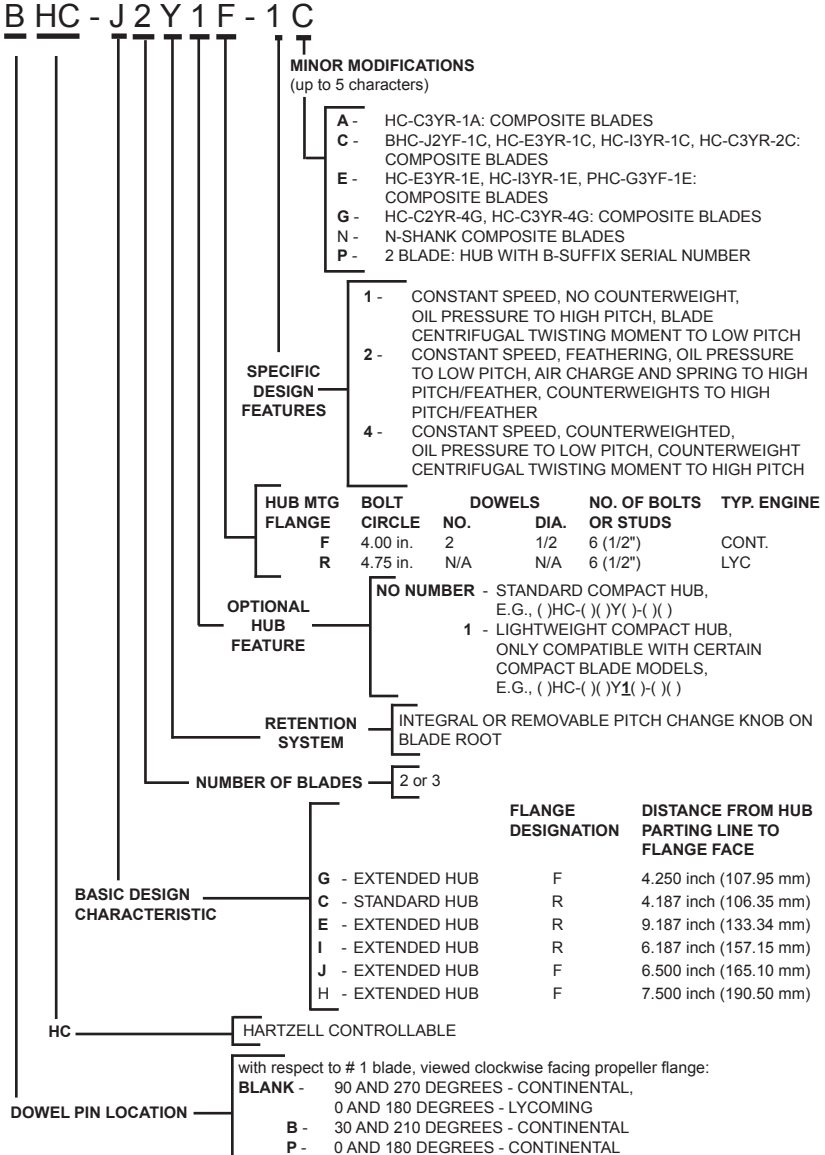

B. Composite Blade Model Identification

Hartzell uses a model designation to identify specific propeller and blade assemblies. Example: HC-J3YF-1C/B7421. A slash mark separates the propeller and blade designations. The propeller model designation is impression stamped on the propeller hub. The blade designation is impression stamped on the blade butt end (internal) and is either on a label or ink stamped on the blade camber side (external).

prop model/B 7421()

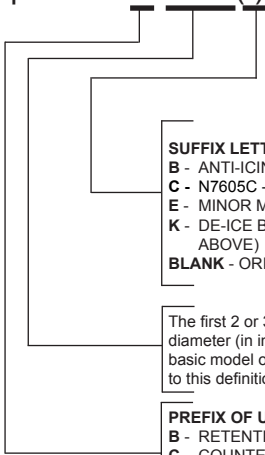

SUFFIX LETTERS:

- B** - ANTI-ICING OR DE-ICE BOOT
- C** - N7605C - N-SHANK CARBON BLADE
- E** - MINOR MODIFICATION
- K** - DE-ICE BOOT INSTALLED (FOIL ELEMENT, DIFFERENT PN FROM B ABOVE)
- BLANK** - ORIGINAL DESIGN, NO CHANGES

The first 2 or 3 numbers indicate initial design diameter (in inches), the last 2 numbers indicate basic model or template (there are some exceptions to this definition).

PREFIX OF UP TO 3 LETTERS:

- B** - RETENTION and PITCH CHANGE KNOB
- C** - COUNTERWEIGHT CLAMP INSTALLED
- N** - N-SHANK
- BLANK** - STANDARD BLADE, RIGHT HAND ROTATION

BLADE TYPE	BLADE MODEL DESIGNATION
Kevlar®	()7690()
	7890K
	B7421(K)
N-shank Kevlar®/ Carbon Hybrid	N7605(B,K)-()
	N()7893-()
N-shank Carbon	N7605C()

**Blade Type and Blade Model Designations
Table 2-1**

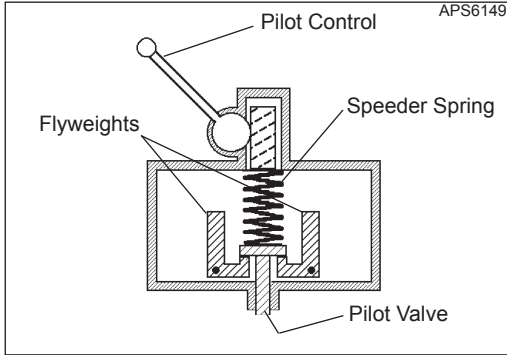

Governor in Onspeed Condition
Figure 2-4

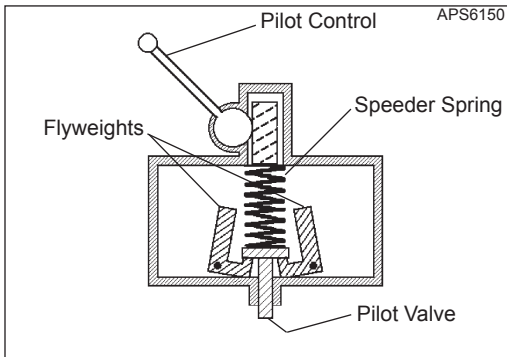

Governor in Underspeed Condition
Figure 2-5

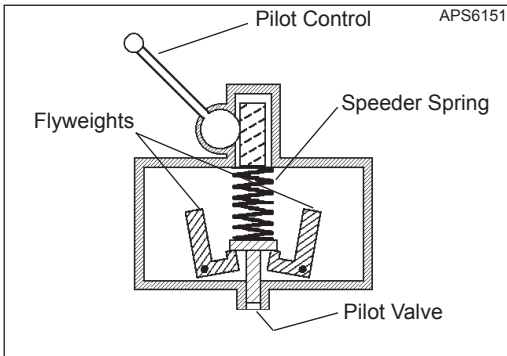

Governor in Overspeed Condition
Figure 2-6

4. Governors**A. Theory of Operation**

A governor is an engine RPM sensing device and high pressure oil pump. In a constant speed propeller system, the governor responds to a change in engine RPM by directing oil under pressure to the propeller hydraulic cylinder or by releasing oil from the hydraulic cylinder. The change in oil volume in the hydraulic cylinder changes the blade angle and maintains the propeller system RPM. The governor is set for a specific RPM via the cockpit propeller control, which compresses or releases the governor speeder spring.

Refer to Figure 2-4. When the engine is operating at the RPM set by the pilot using the cockpit control, the governor is operating **onspeed**. In an onspeed condition, the centrifugal force acting on the flyweights is balanced by the speeder spring, and the pilot valve is neither directing oil to nor from the propeller hydraulic cylinder.

Refer to Figure 2-5. When the engine is operating below the RPM set by the pilot using the cockpit control, the governor is operating **underspeed**. In an underspeed condition, the flyweights tilt inward because there is not enough centrifugal force on the flyweights to overcome the force of the speeder spring. The pilot valve, forced down by the speeder spring, meters oil flow to decrease propeller pitch and raise engine RPM.

Refer to Figure 2-6. When the engine is operating above the RPM set by the pilot using the cockpit control, the governor is operating **overspeed**. In an overspeed condition, the centrifugal force acting on the flyweights is greater than the speeder spring force. The flyweights tilt outward, and raise the pilot valve. The pilot valve then meters oil flow to increase propeller pitch and lower engine RPM.

Refer to Figure 2-7. This figure illustrates a governor as a component of a synchronizing or synchrophasing system. A synchronizing system is employed in a multi-engine aircraft to keep the engines operating at the same RPM. A synchrophasing system not only keeps RPM of the engines consistent, but also keeps the propeller blades operating in phase with each other. Both synchronizing and synchrophasing systems serve to reduce noise and vibration.

A Hartzell synchronizing or synchrophasing system uses one engine (the master engine) as an RPM and phase reference and adjusts the RPM of the remaining engine(s) [slave engine(s)] to match it. The RPM of the master engine is monitored electronically, and this information is used to adjust the voltage applied to the electrical coil on the slave governor(s). The voltage to the coil either raises or lowers a rod which changes the force of the speeder spring. In this manner, engine RPM and phase of the propellers is synchronized or synchrophased.

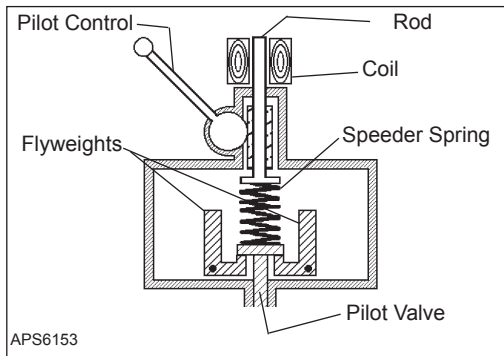

**Synchronizer/Synchrophaser Governor
Figure 2-7**

B. Governor Types

The governors commonly used in Hartzell Compact Constant Speed propeller systems are supplied either by Hartzell or several other manufacturers. These governor types function in a similar manner.

C. Identification of Hartzell Governors

Hartzell governor may be identified by model number as follows:

(X) - (X) - (X)

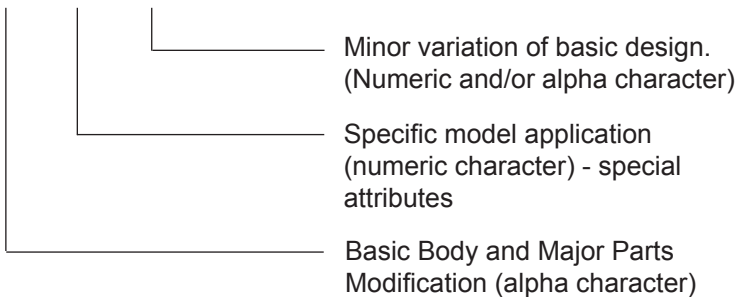

NOTE: Refer to Hartzell Governor Manual 130B (61-23-30) for maintenance and overhaul instructions for Hartzell governors.

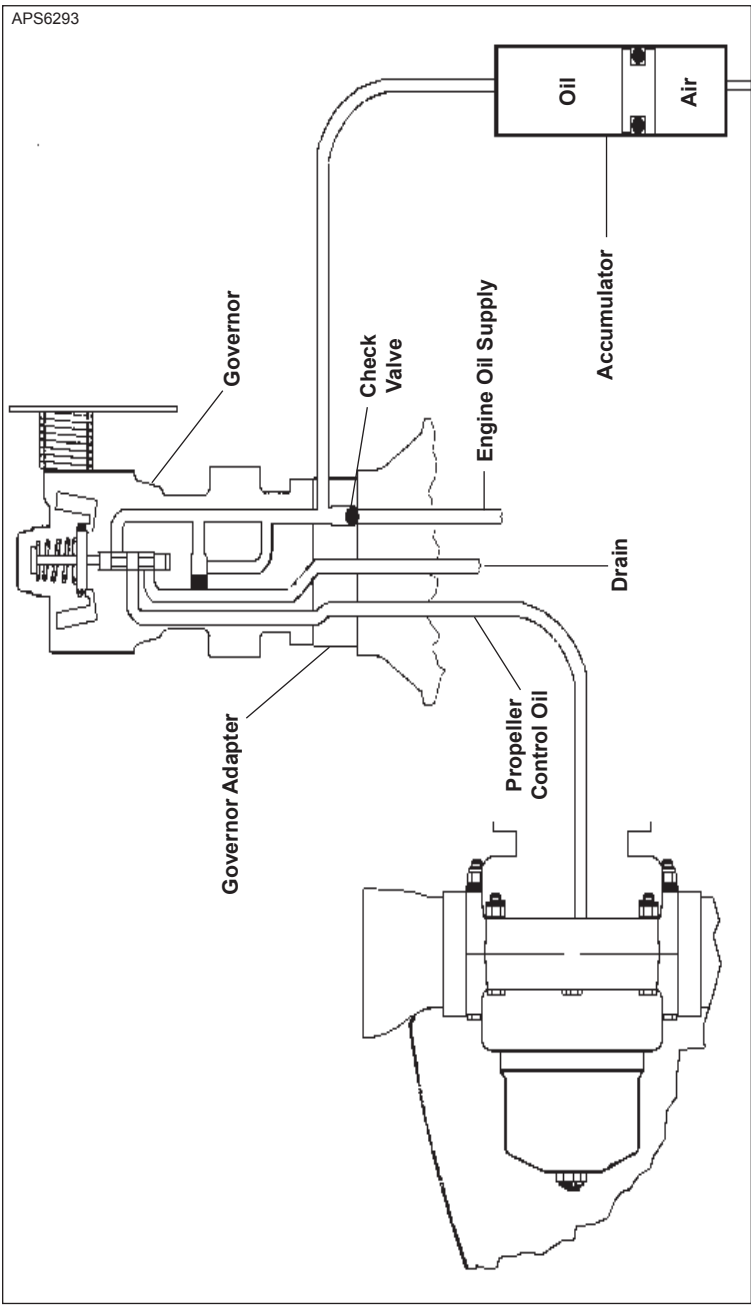

**Governor/Accumulator System
Figure 2-8**

5. Accumulators

NOTE: Accumulators are used on HC-C3YR-1A propellers with composite propeller blades only.

CAUTION: THE EFFECTIVENESS OF THE ACCUMULATOR SYSTEM CANNOT BE ACCURATELY SPECIFIED DUE TO VARIABLES IN THE ENGINE AND GOVERNOR INTERNAL LEAKAGE RATES, AS WELL AS THE EXTENT AND DURATION OF OIL STARVATION. THE SYSTEM CANNOT ENSURE 100 PERCENT PROTECTION FROM OVERSPEED IN ALL OPERATING CONDITIONS.

The fundamental purpose of the accumulator is to supply oil to the governor during brief circumstances of engine oil starvation, not prolonged periods of this condition. The accumulator's oil supply helps to avoid loss of propeller control and overspeed.

A. System Overview (See Figure 2-8)

The accumulator has a one (1) quart capacity for the oil and the volume required for an air charge. A piston or diaphragm separates the oil and air.

When the engine is operating, the engine oil system supplies oil to the input side of the governor gear pump. The oil supply also charges the accumulator at any time the engine oil system is developing a pressure greater than the accumulator air charge pressure. The accumulator is filled with oil until the air charge pressure of the compressed air volume is equal to the engine oil pressure.

In the event that the engine oil pressure drops below the accumulator air pressure, the oil in the accumulator is discharged to supply the governor gear pump. A check valve in an adapter located between the engine and governor will prevent the accumulator from discharging oil into the engine. The loss of propeller control and overspeed are avoided while an oil supply to the governor is maintained.

6. Propeller Ice Protection Systems

Some Hartzell compact propellers may be equipped with an anti-ice or a de-ice system. A short description of each of these systems follows:

A. Propeller Anti-ice System

A propeller anti-ice system prevents ice from forming on propeller surfaces. The system dispenses a liquid (usually isopropyl alcohol) that mixes with moisture on the propeller blades, reducing the freezing point of the water. This water/alcohol mixture flows off the blades before ice forms. This system must be in use before ice forms. It is ineffective in removing ice that has already formed.

(1) System Overview

- (a) A typical anti-ice system consists of a fluid tank, pump, and distribution tubing.
- (b) The rate at which the anti-icing fluid is dispensed is controlled by a pump speed rheostat in the cockpit.
- (c) The anti-icing fluid is dispensed through airframe mounted distribution tubing and into a rotating slinger ring mounted on the rear of the propeller hub. The anti-icing fluid is then directed through blade feed tubes from the slinger ring onto the blades via centrifugal force. The anti-icing fluid is directed onto anti-icing boots that are attached to the leading edge of the blade. These anti-icing boots evenly distribute and direct the fluid along the blade leading edge.

B. Propeller De-ice System

A propeller de-ice system permits ice to form, and then removes it by electrically heating the de-ice boots. The ice partially melts and is thrown from the blade by centrifugal force.

(1) System Overview

- (a) A de-ice system consists of one or more on/off switches, a timer or cycling unit, a slip ring, brush blocks, and de-ice boots. The pilot controls the operation of the de-ice system by turning on one or more switches. All de-ice systems have a master switch, and may have another toggle switch for each propeller. Some systems also have a selector switch to adjust for light or heavy icing conditions.
- (b) The timer or cycling unit determines the sequence of which blades (or portion thereof) are currently being de-iced, and for what length of time. The cycling unit applies power to each de-ice boot or boot segment in a sequential order.
- (c) A brush block, which is normally mounted on the engine just behind the propeller, is used to transfer electricity to the slip ring. The slip ring rotates with the propeller, and provides a current path to the blade de-ice boots.
- (d) De-ice boots contain internal heating elements. These boots are securely attached to the inboard leading edges of each blade with adhesive.

(This page is intentionally blank.)

INSTALLATION AND REMOVAL - CONTENTS

	<u>Page</u>
1. Tools, Consumables, and Expendables	3-3
A. Tooling.....	3-3
B. Consumables	3-3
C. Expendables	3-3
2. Pre-Installation.....	3-7
A. Inspection of Shipping Package.....	3-7
B. Uncrating.....	3-7
C. Inspection after Shipment	3-7
D. Reassembly of a Propeller Disassembled for Shipment.....	3-7
E. Air Charge Pressure Check (-2 Propellers)	3-7
3. Spinner Pre-Installation	3-9
A. General	3-9
B. Installation of a Metal Spinner Bulkhead on a Propeller Hub	3-11
C. Installation of a Composite Spinner Bulkhead on a Propeller Hub	3-13
4. Propeller Installation	3-15
A. Flange Description	3-15
B. Installation of "F" Flange Propellers	3-17
C. Installation of "R" Flange Propellers.....	3-21
5. Spinner Installation	3-25
A. Single Piece Spinner Dome	3-25
B. Two-piece Spinner Dome (Procedure 1).....	3-27
C. Two-Piece Spinner Dome (Procedure 2)	3-29
6. Post-Installation Checks	3-30
7. Spinner Removal	3-30
A. Removal of Single Piece Spinner	3-30
B. Removal of Two-Piece Spinner.....	3-30
C. Hub Mounted Spinner Bulkhead Removal.....	3-30
D. Starter Ring Gear Spinner Adapter Removal.....	3-31

INSTALLATION AND REMOVAL - CONTENTS, CONTINUED

8. Propeller Removal.....	3-31
A. Removal of "F" Flange Propellers.....	3-31
B. Removal of "R" Flange Propellers.....	3-33

LIST OF FIGURES

	<u>Page</u>
Determining Torque Value When Using Torquing Adapter.....	Figure 3-1..... 3-4
Diagram of Torquing Sequence for Propeller Mounting Hardware.....	Figure 3-2..... 3-6
Hub Clamping Bolt Location.....	Figure 3-3..... 3-8
Metal Bulkhead and Spinner Mounting (Hub Mounted Spinner).....	Figure 3-4..... 3-10
Composite Bulkhead and Spinner Mounting (Hub Mounted Spinner).....	Figure 3-5..... 3-12
F Flange Propeller Mounting.....	Figure 3-6..... 3-16
R Flange Propeller Mounting.....	Figure 3-7..... 3-20
Two-Piece Spinner Mounting (Procedure 1)...	Figure 3-8..... 3-26
Two-Piece Spinner Mounting (Procedure 2)...	Figure 3-9..... 3-28
Spinner Dome-to-Bulkhead Mounting Hole Alignment.....	Figure 3-10..... 3-28

LIST OF TABLES

	<u>Page</u>
Torque Table.....	Table 3-1..... 3-5
Metal Spinner Bulkhead Mounting Hardware.....	Table 3-2..... 3-11
Composite Spinner Bulkhead Mounting Hardware.....	Table 3-3..... 3-13
Propeller/Engine Flange O-rings and Hardware.....	Table 3-4..... 3-14
Spinner Dome and Spinner Cap Mounting Hardware.....	Table 3-5..... 3-24

1. Tools, Consumables, and Expendables

The following tools, consumables, and expendables will be required for propeller removal or installation:

NOTE: Compact propellers with composite blades are manufactured with one two basic hub mounting flange designs. The flange types are F or R. The flange type used on a particular propeller installation is indicated in the propeller model number stamped on the hub. For example, BHC-J2YE-1C indicates an F flange. Refer to Aluminum Hub Propeller Model Identification in the Description and Operation chapter of this manual for a description of each flange.

A. Tooling**F Flange**

- Safety wire pliers
- Torque wrench (1/2 inch drive)
- Torque wrench adapter
(Hartzell Part Number BST-2860 or 101939)
- 3/4 inch open end wrench

R Flange

- Safety wire pliers
- Torque wrench (1/2 inch drive)
- Torque wrench adapter
(Hartzell Part Number BST-2860 or 101939)
- 3/4 inch open end wrench

B. Consumables

- Quick Dry Stoddard Solvent or MEK

C. Expendables

- 0.032 Aircraft Safety wire
- O-ring (see Table 3-4)

APS0212A

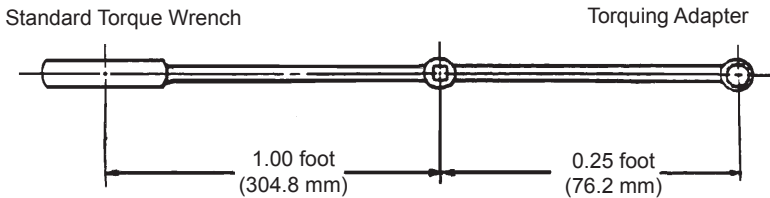

$$\frac{(\text{actual torque required}) \times (\text{torque wrench length})}{(\text{torque wrench length}) + (\text{length of adapter})} = \text{Torque wrench reading to achieve required actual torque}$$

EXAMPLE:

$$\frac{100 \text{ Ft-Lb (136 N}\cdot\text{m)} \times 1.00 \text{ ft (304.8 mm)}}{1.00 \text{ ft (304.8 mm)} + 0.25 \text{ ft (76.2 mm)}} = 80 \text{ Ft-Lb (108 N}\cdot\text{m)} < \text{reading on torque wrench with 3-inch (76.2 mm) adapter for actual torque of 100 Ft-Lb (136 N}\cdot\text{m)}$$

The correction shown is for an adapter that is aligned with the centerline of the torque wrench. If the adapter is angled 90 degrees relative to the torque wrench centerline, the torque wrench reading and actual torque applied will be equal.

Determining Torque Value When Using Torquing Adapter Figure 3-1

Installation Torques	
CAUTION 1: MOUNTING HARDWARE MUST BE CLEAN AND DRY TO PREVENT EXCESSIVE PRELOAD OF THE MOUNTING FLANGE.	
CAUTION 2: ALL TORQUES LISTED ARE DRY TORQUE.	
CAUTION 3: REFER TO FIGURE 3-1 FOR TORQUE READING WHEN USING A TORQUE WRENCH ADAPTER.	
For ()HC-()Y()-() ONLY Hub clamping bolts/spinner mounting nuts	20-22 ft-lbs (28-29 N•m)
For ()HC-()3Y1()-1() ONLY Hub clamping bolts/spinner mounting nuts	24-26 ft-lbs (33-35 N•m)
F flange propeller mounting nuts	70-80 ft-lbs (95-108 N•m)
For all R flange propeller mounting studs	60-70 ft-lbs (82-94 N•m)
Low pitch stop jam nut P/N A-2043-1 -1 Application (See Figure 6-17)	14-16 ft-lbs (19-21 N•m)
Low pitch stop jam nut P/N B-3359 -1 Application (See Figure 6-17)	14-16 ft-lbs (19-21 N•m)
Low pitch stop jam nut P/N B-3599 -1 Application (See Figure 6-17)	14-16 ft-lbs (19-21 N•m)
Low pitch stop jam nut P/N A-2043-1 -4 Application (See Figure 6-17)	27-33 ft-lbs (37-44 N•m)
Low pitch stop jam nut P/N B-3359 -4 Application (See Figure 6-17)	27-33 ft-lbs (37-44 N•m)
Low pitch stop jam nut P/N B-3599 -4 Application (See Figure 6-17)	27-33 ft-lbs (37-44 N•m)
Low pitch stop jam nut P/N B-3807 -4 Application (See Figure 6-17)	27-33 ft-lbs (37-44 N•m)

**Torque Table
Table 3-1**

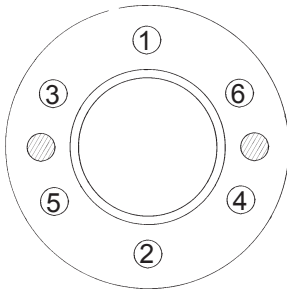

F Flange

Step 1 - Torque all mounting nuts to 40 Ft-Lbs (54 N•m) in the sequence shown

Step 2 - Torque all mounting nuts in accordance with Table 3-1 and Figure 3-1 in the sequence shown

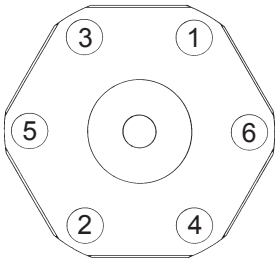

R Flange

Step 1 - Torque all mounting studs to 40 Ft-Lbs (54 N•m) in the sequence shown

Step 2 - Torque all mounting studs in accordance with Table 3-1 and Figure 3-1 in the sequence shown

**Diagram of Torquing Sequence for Propeller Mounting Hardware
Figure 3-2**

2. Pre-Installation**A. Inspection of Shipping Package**

- (1) Examine the exterior of the shipping container, especially the box ends around each blade, for signs of shipping damage. A hole, or tear, or crushed appearance at the end of the box (blade tips) may indicate that the propeller was dropped during shipment, possibly damaging the blades.

B. Uncrating

- (1) Put the propeller on a firm support.
- (2) Remove the banding and any external wood bracing from the cardboard shipping container.
- (3) Remove the cardboard from the hub and blades.

CAUTION: DO NOT STAND THE PROPELLER ON A BLADE TIP.

- (4) Put the propeller on a padded surface that supports the entire length of the propeller.
- (5) Remove the plastic dust cover cup from the propeller mounting flange, if installed.

C. Inspection after Shipment

- (1) After removing the propeller from the shipping container, examine the propeller components for shipping damage.

D. Reassembly of a Propeller Disassembled for Shipment

- (1) If a propeller was received disassembled for shipment, it must be reassembled by trained personnel in accordance with the applicable propeller maintenance manual.

E. Air Charge Pressure Check (-2 Propellers)

- (1) Perform an air charge pressure check before propeller installation. Refer to the Air Charge section of the Maintenance Practices chapter of this manual.
 - (a) If the air pressure loss is less than 10 percent of the specified pressure, reservice the propeller.
 - (b) If the air pressure loss is greater than 10 percent of the specified pressure, repair the propeller. This repair must be performed at an appropriately licensed repair facility.

APS6158

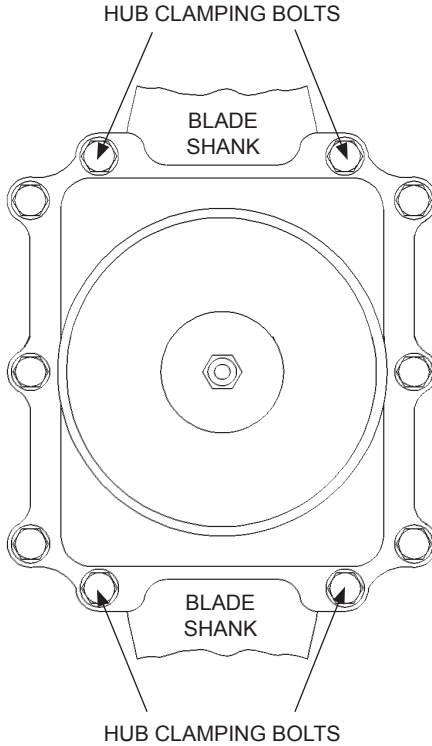

Hub Clamping Bolt Location
Figure 3-3

3. Spinner Pre-Installation**A. General**

- (1) The spinner support must be mounted before the propeller can be installed. The spinner will mount to a bulkhead installed on the propeller hub. Follow the applicable directions in this section.
- (2) Refer to Figure 3-3. Remove the nuts from the hub clamping bolts that are located on either side of the blade shank. Do not remove the bolts. The remaining nuts/bolts should not be disturbed.
- (3) Refer to Figure 3-3. The spinner may be supplied with long hub clamping bolts. If the bolts were supplied with the spinner, remove the bolts on either side of the blade shank and replace them with the bolts supplied with the spinner. The supplied hub clamping bolts will be longer than those removed from the hub.

NOTE: Depending upon the installation, the propeller hub may have been shipped from the factory with the longer hub clamping bolts installed. In this case, the hub clamping bolts will not be supplied with the spinner.

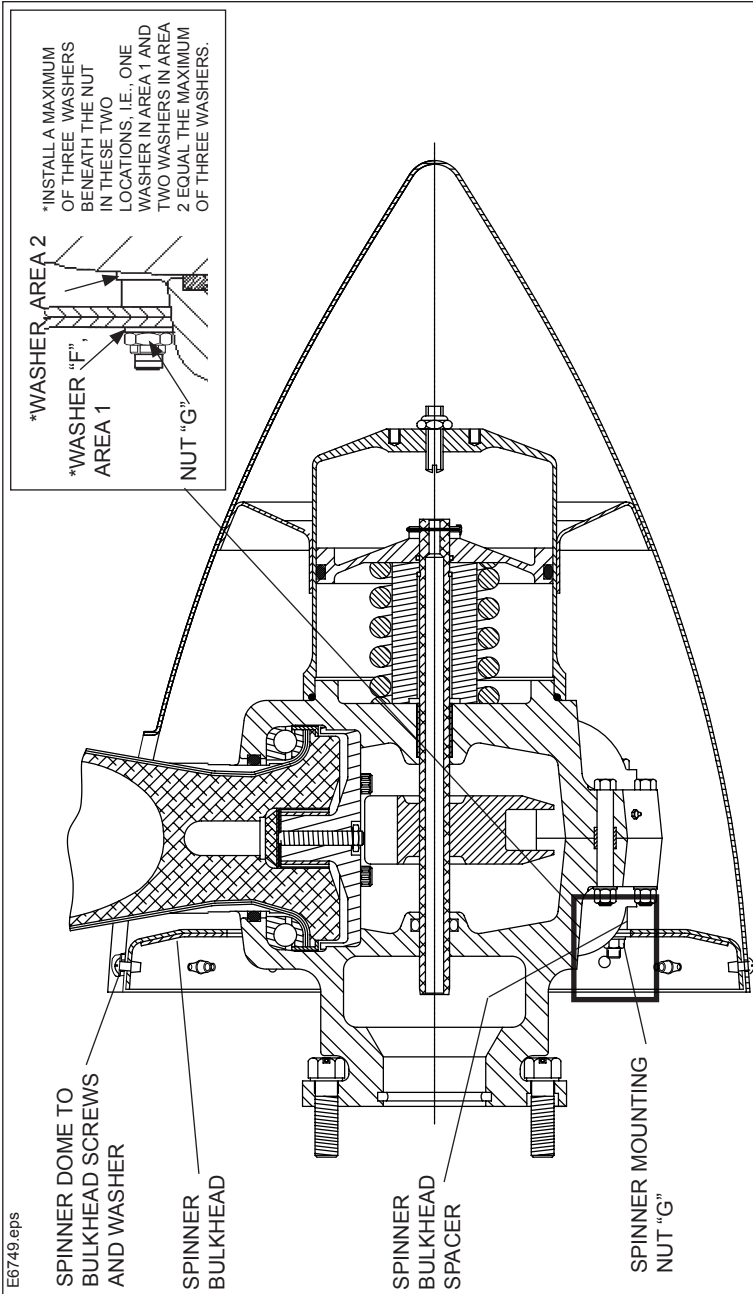

Metal Bulkhead and Spinner Mounting (Hub Mounted Spinner)
Figure 3-4

- B. Installation of a Metal Spinner Bulkhead on a Propeller Hub
- (1) Refer to Figure 3-4. Put the spinner bulkhead spacers on the hub clamping bolts. Install the spinner bulkhead over the installed spacers on the hub clamping bolts.

CAUTION: A MINIMUM OF ONE THREAD OF THE HUB CLAMPING BOLT MUST BE VISIBLE AFTER THE SPINNER MOUNTING NUT IS INSTALLED.

- (2) When the spinner bulkhead is installed, there must be no less than one thread of the hub clamping bolt exposed beyond the spinner mounting nut. A total of three washers in two areas may be installed beneath the spinner mounting nut to achieve this result. On some installations, it may be necessary to install spacers and one or more washers beneath the head of the bolt to avoid interference with aircraft cowling.
- (a) Additional washers (as many as four) may have been used for hub clamping purposes during assembly of the propeller.
- 1 Use the quantity of washers required when installing the bulkhead for correct spinner position. Refer to Figure 3-4.
 - 2 After the correct installation of the spinner, any remaining washers may be discarded.
- (3) Install at least one flat washer "F" and a new self-locking spinner mounting nut "G" on each hub clamping bolt used to mount the spinner bulkhead. Refer to Table 3-2.
- (4) Torque each spinner mounting nut in accordance with Table 3-1, Figure 3-1, and Figure 3-2.

Description	Part Number
Flat Washer "F"	B-3824-0663
Spinner Mounting Nut "G"	B-3599

**Metal Spinner Bulkhead Mounting Hardware
Table 3-2**

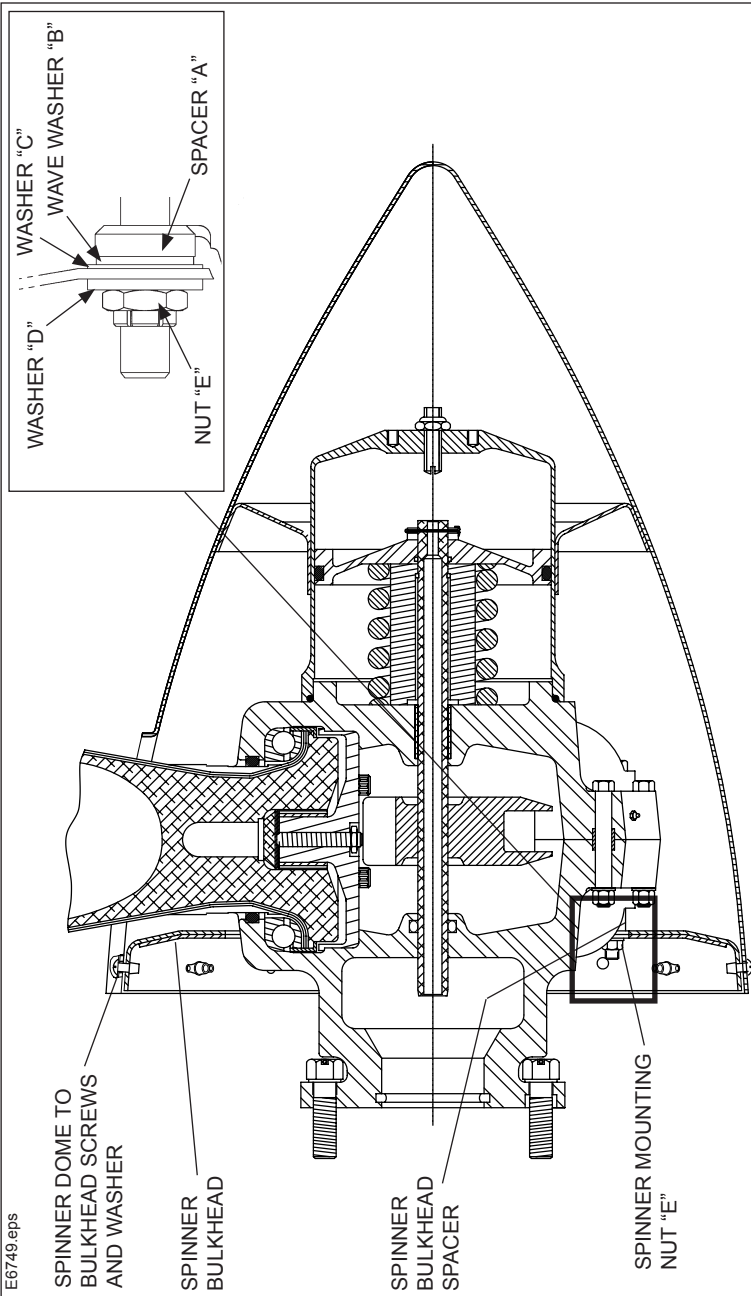

Composite Bulkhead and Spinner Mounting (Hub Mounted Spinner)
Figure 3-5

E6749.eps

- C. Installation of a Composite Spinner Bulkhead on a Propeller Hub - Refer to Table 3-3 and Figure 3-5
- (1) Put a spinner bulkhead spacer "A", wave washer "B", and washer "C" on each of the hub clamping bolts.
 - (2) Install the spinner bulkhead over the installed spacers "A", wave washers "B", and washers "C" on the hub clamping bolts.
 - (3) Install a flat washer "D" and a new self-locking spinner mounting nut "E" on each of the hub clamping bolts used to mount the spinner bulkhead.

CAUTION: A MINIMUM OF ONE THREAD OF THE HUB CLAMPING BOLT MUST BE VISIBLE AFTER THE SPINNER MOUNTING NUT IS INSTALLED.

- (a) When the spinner bulkhead is installed, there must be no less than one thread of the hub clamping bolt exposed beyond the spinner mounting nut "E".
- (4) Torque each spinner mounting nut "E" in accordance with Table 3-1, Figure 3-1, and Figure 3-2.

Description	Part Number
Spinner Bulkhead Spacer "A"	B-7424-1
Wave Washer "B"	B-7425
Washer "C"	B-3834-0832
Flat Washer "D"	B-7423
Spinner Mounting Nut "E"	B-3599

**Composite Spinner Bulkhead Mounting Hardware
Table 3-3**

Flange	O-ring	Stud/Bolt	Nut	Washer/ Spacer	Spring Pin
"F"	C-3317-228	n/a	A-2044	A-1381*	n/a
"R"	C-3317-228	A-2067	A-2069	A-1381	B-3842-0625

* **NOTE:** Do not install the A-1381 washer on installations that use Goodrich Corp. part number 4E1881 or 4E2058 split mounting plate.

**Propeller/Engine Flange O-rings and Hardware
Table 3-4**

WARNING: FAILURE TO FOLLOW THESE INSTALLATION INSTRUCTIONS MAY LEAD TO PROPELLER DAMAGE, ENGINE DAMAGE, OR PROPELLER FAILURE, WHICH MAY RESULT IN DEATH, SERIOUS BODILY INJURY, AND/OR SUBSTANTIAL PROPERTY DAMAGE. UNUSUAL OR ABNORMAL VIBRATION DEMANDS IMMEDIATE INSPECTION FOR IMPROPER PROPELLER INSTALLATION. PROPELLER SEPARATION MAY OR MAY NOT BE PROCEEDED BY VIBRATION.

4. Propeller Installation

A. Flange Description

CAUTION: SOME STEEL HUB PROPELLERS INCORPORATE A PHENOLIC SPACER BETWEEN THE PROPELLER AND ENGINE-MOUNTING FLANGE. WHEN INSTALLING AN ALUMINUM HUB PROPELLER, THIS SPACER MUST BE DISCARDED. THE ALUMINUM HUB PROPELLER MOUNTING O-RING IS LOCATED ON THE INSIDE DIAMETER OF THE PROPELLER HUB. THERE SHOULD NOT BE AN O-RING ON THE ENGINE FLANGE WHEN INSTALLING AN ALUMINUM HUB PROPELLER.

- (1) Hartzell compact propellers with composite blades are manufactured with two basic hub mounting flange designs.
- (2) The flange type designators are F or R. The flange type used on a particular propeller installation is indicated in the propeller model stamped on the hub. For example, HC-C3YR-1A indicates an R flange.
- (3) Refer to Aluminum Hub Propeller Model Identification in the Description and Operation Chapter of this manual for description of each flange type. Sample flanges are also shown in Figure 3-6 and Figure 3-7.

APS6159C

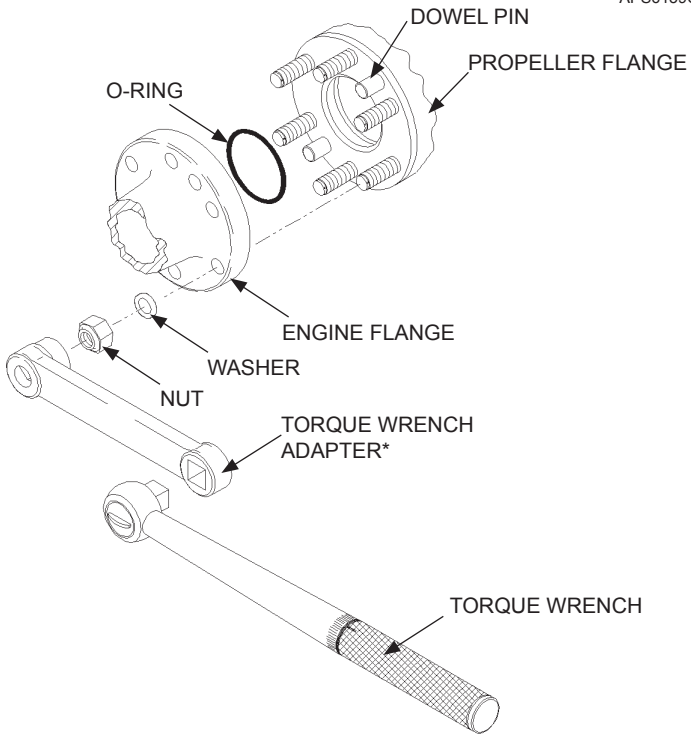

***NOTE:** If a torque wrench adapter is used, use the calculation in Figure 3-4 to determine correct torque wrench setting.

APS6171

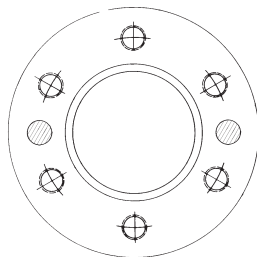

F Flange

**F Flange Propeller Mounting
Figure 3-6**

B. Installation of "F" Flange Propellers**(1) General**

- (a) An "F" flange propeller has six 1/2 inch diameter studs configured in a four inch circle.
- (b) Two dowel pins are also supplied to transfer torque and index the propeller with respect to the engine crankshaft. See Figure 3-6.
- (c) The dowel pin locations used on a particular propeller installation are indicated in the propeller model stamped on the hub. Refer to Aluminum Hub Propeller Model Identification in the Description and Operation Chapter of this manual.

(2) Perform the applicable steps under Spinner Pre-Installation within this chapter.

WARNING: CLEANING AGENTS ARE FLAMMABLE AND TOXIC TO THE SKIN, EYES AND RESPIRATORY TRACT. SKIN AND EYE PROTECTION IS REQUIRED. AVOID PROLONGED CONTACT. USE IN WELL VENTILATED AREA.

- (3) Clean the engine flange and propeller flange with Quick Dry Stoddard Solvent or MEK.
- (4) Refer to Figure 3-6. Lubricate the mounting flange O-ring with engine oil. Install the O-ring in the O-ring groove in the hub bore. Refer to Table 3-4 for the applicable O-ring and mounting hardware.

NOTE: When the propeller is received from the factory, the O-ring has been installed.

WARNING: MAKE SURE THAT ANY EQUIPMENT USED TO INSTALL THE PROPELLER IS RATED UP TO 800 LBS. (363 KG) TO SUPPORT THE WEIGHT OF THE PROPELLER ASSEMBLY DURING INSTALLATION. ONE PERSON MUST NEVER ATTEMPT TO INSTALL AN UNSUPPORTED PROPELLER BY HIMSELF, REGARDLESS OF THE SIZE OR WEIGHT OF THE PROPELLER. MANUALLY LIFTING THE PROPELLER ONTO THE ENGINE CAN RESULT IN PERSONAL INJURY.

CAUTION 1: A PROPELLER MUST BE CORRECTLY SUPPORTED DURING INSTALLATION ON THE ENGINE. AVOID ANY ROCKING OR SHIFTING OF THE PROPELLER WHEN IT IS PARTIALLY ENGAGED WITH THE ENGINE. ROCKING OF THE PROPELLER DURING PROPELLER INSTALLATION CAN DAMAGE THE PROPELLER HUB MOUNTING FACE, CAUSING ACTUATION OIL LEAKAGE OR DAMAGE THAT MAY SCRAP THE HUB. HUB DAMAGE CAN ALSO INTRODUCE METAL INTO THE PROPELLER OIL ACTUATION SYSTEM, WHICH COULD POSSIBLY DAMAGE THE ENGINE.

CAUTION 2: WHEN INSTALLING THE PROPELLER ON THE AIRCRAFT, DO NOT DAMAGE THE ICE PROTECTION SYSTEM COMPONENTS, IF APPLICABLE.

- (5) With a suitable support, such as a crane hoist or similar equipment, carefully move the propeller assembly to the aircraft engine mounting flange in preparation for installation.
- (6) Install the propeller on the engine flange. Make sure to align the dowel pins in the propeller flange with the corresponding holes in the engine mounting flange.

- (a) The propeller may be installed on the engine flange in a given position, or 180 degrees from that position. Check the engine and airframe manuals to determine if either manual specifies a propeller mounting position.

CAUTION 1: MOUNTING HARDWARE MUST BE CLEAN AND DRY TO PREVENT EXCESSIVE PRELOAD OF THE MOUNTING FLANGE.

CAUTION 2: TIGHTEN NUTS EVENLY TO AVOID HUB DAMAGE.

- (7) Install the 1/2 inch propeller mounting nuts (dry) with spacers. Refer to Table 3-4.
- (8) Torque the 1/2 inch propeller mounting nuts (dry) in accordance with Table 3-1, Figure 3-1, and Figure 3-2. Safety wire the studs in pairs (if required by aircraft maintenance manual) at the rear of the propeller mounting flange. Refer to Figure 3-4.
- (9) If the propeller is equipped with an ice protection system that uses components supplied by Hartzell Propeller Inc., applicable instructions and technical information for the components supplied by Hartzell can be found in the following publications available on the Hartzell website at www.hartzellprop.com:
- (a) Manual 180 (30-61-80) - Propeller Ice Protection System Manual
 - (b) Manual 181 (30-60-81) - Propeller Ice Protection System Component Maintenance Manual
 - (c) Manual 182 (61-12-82) - Propeller Electrical De-ice Boot Removal and Installation Manual
 - (d) Manual 183 (61-12-83) - Propeller Anti-icing Boot Removal and Installation Manual
- (10) Propeller ice protection system components not supplied by Hartzell Propeller Inc. are controlled by the applicable TC or STC holder's Instructions for Continued Airworthiness (ICA).
- (11) Install the propeller spinner dome in accordance with the section "Spinner Installation" in this chapter.

APS6160D

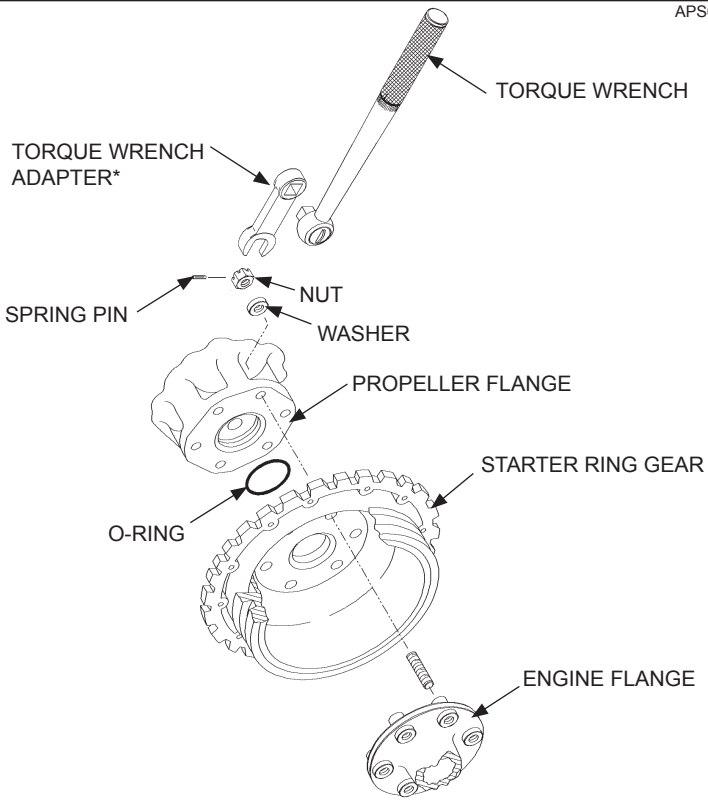

***NOTE:** If a torque wrench adapter is used, use the calculation in Figure 3-1 to determine correct torque wrench setting

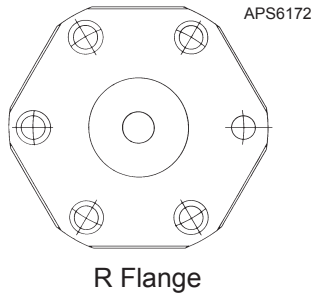

**R Flange Propeller Mounting
Figure 3-7**

C. Installation of "R" Flange Propellers**(1) General**

- (a) An "R" flange is an SAE No. 2 flange that has six 1/2 inch diameter studs configured in a 4.75 inch circle.
- (b) Five drive bushings transfer torque and index the propeller with respect to the engine crankshaft. The bushings are located on the engine flange and fit into counterbored holes on the propeller flange. Refer to Figure 3-7.
- (c) The bushing locations used on a particular propeller installation are indicated in the propeller model stamped on the hub. Refer to Aluminum Hub Propeller Model Identification in the Description and Operation chapter of this manual.

- (2) Perform the applicable steps under Spinner Pre-Installation within this chapter.

WARNING: CLEANING AGENTS ARE FLAMMABLE AND TOXIC TO THE SKIN, EYES AND RESPIRATORY TRACT. SKIN AND EYE PROTECTION IS REQUIRED. AVOID PROLONGED CONTACT. USE IN WELL VENTILATED AREA.

- (3) Clean the engine flange and propeller flange with Quick Dry Stoddard Solvent or MEK.
- (4) Refer to Figure 3-7. Install the O-ring in the O-ring groove in the rear of the hub. Refer to Table 3-4 for the applicable O-ring and mounting hardware.

NOTE: When the propeller is received from the factory, the O-ring has been installed.

WARNING: MAKE SURE THAT ANY EQUIPMENT USED TO INSTALL THE PROPELLER IS RATED UP TO 800 LBS. (363 KG) TO SUPPORT THE WEIGHT OF THE PROPELLER ASSEMBLY DURING INSTALLATION. ONE PERSON MUST NEVER ATTEMPT TO INSTALL AN UNSUPPORTED PROPELLER BY HIMSELF, REGARDLESS OF THE SIZE OR WEIGHT OF THE PROPELLER. MANUALLY LIFTING THE PROPELLER ONTO THE ENGINE CAN RESULT IN PERSONAL INJURY.

CAUTION 1: A PROPELLER MUST BE CORRECTLY SUPPORTED DURING INSTALLATION ON THE ENGINE. AVOID ANY ROCKING OR SHIFTING OF THE PROPELLER WHEN IT IS PARTIALLY ENGAGED WITH THE ENGINE. ROCKING OF THE PROPELLER DURING PROPELLER INSTALLATION CAN DAMAGE THE PROPELLER HUB MOUNTING FACE, CAUSING ACTUATION OIL LEAKAGE OR DAMAGE THAT MAY SCRAP THE HUB. HUB DAMAGE CAN ALSO INTRODUCE METAL INTO THE PROPELLER OIL ACTUATION SYSTEM, WHICH COULD POSSIBLY DAMAGE THE ENGINE.

CAUTION 2: WHEN INSTALLING THE PROPELLER ON THE AIRCRAFT, DO NOT DAMAGE THE ICE PROTECTION SYSTEM COMPONENTS, IF APPLICABLE.

- (5) With a suitable support, such as a crane hoist or similar equipment, carefully move the propeller assembly to the aircraft engine mounting flange in preparation for installation.
- (6) Install the propeller on the engine flange. Align the engine flange bushings with the corresponding holes in the propeller flange.

CAUTION 1: MOUNTING HARDWARE MUST BE CLEAN AND DRY TO PREVENT EXCESSIVE PRELOAD OF THE MOUNTING FLANGE

CAUTION 2: TIGHTEN NUTS EVENLY TO AVOID HUB DAMAGE

- (7) Torque the 1/2 inch diameter propeller mounting studs (dry) in accordance with Table 3-1, Figure 3-1, and Figure 3-2. Safety wire the mounting studs in pairs (if required by the aircraft maintenance manual) at the rear of the propeller mounting flange. Refer to Figure 3-7.
- (8) If the propeller is equipped with an ice protection system that uses components supplied by Hartzell Propeller Inc., applicable instructions and technical information for the components supplied by Hartzell can be found in the following publications available on the Hartzell website at www.hartzellprop.com:
- (a) Manual 180 (30-61-80) - Propeller Ice Protection System Manual
 - (b) Manual 181 (30-60-81) - Propeller Ice Protection System Component Maintenance Manual
 - (c) Manual 182 (61-12-82) - Propeller Electrical De-ice Boot Removal and Installation Manual
 - (d) Manual 183 (61-12-83) - Propeller Anti-icing Boot Removal and Installation Manual
- (9) Propeller ice protection system components not supplied by Hartzell Propeller Inc. are controlled by the applicable TC or STC holder's Instructions for Continued Airworthiness (ICA).
- (10) Install the propeller spinner dome in accordance with the section "Spinner Installation" in this chapter.

Dome or Cap	Washer	Screw
Metal Spinner Dome	A-1020 Fiber	B-3845-8 10-32, Truss Head
Metal Spinner Cap	n/a	B-3866-50 8-32, 100° Head, Cres
Composite Spinner Dome	B-3860-10L Dimpled, 100°, Cres.	B-3867-272 10-32, 100° Head, Cres

**Spinner Dome and Spinner Cap Mounting Hardware
Table 3-5**

5. Spinner Installation

CAUTION: TO PREVENT DAMAGE TO THE BLADE AND BLADE PAINT, WRAP THE BLADE SHANKS IN SEVERAL LAYERS OF MASKING OR DUCT TAPE BEFORE INSTALLING THE SPINNER DOME. REMOVE THE TAPE AFTER THE SPINNER IS INSTALLED.

A. Single Piece Spinner Dome

- (1) The following instructions relate to Hartzell spinners only. In some cases, the airframe manufacturer produced the spinner assembly. If so, refer to the airframe manufacturer's manual for spinner installation instructions.

CAUTION: THE SPINNER DOME INTERNAL SUPPORT MUST FIT SNUGLY ON THE CYLINDER. AN IMPROPERLY SUPPORTED DOME COULD CAUSE CYLINDER DAMAGE OR A CRACK IN THE DOME OR BULKHEAD.

- (2) The spinner dome has an internal support (refer to Figure 2-1) that encircles the propeller cylinder. The cylinder may need to be wrapped with one or more layers of UHMW tape (Hartzell Part Number B-6654-100).
- (3) Install the spinner and check for a snug fit where the internal support contacts the cylinder. If the support does not fit snugly on the cylinder, apply a layer of tape and recheck. Repeat until the spinner support fits snugly on the cylinder.

CAUTION: TO AVOID DAMAGING THE AIRCRAFT COWLING, THE SCREWS MUST NOT EXTEND MORE THAN THREE THREADS PAST THE BULKHEAD NUTPLATES.

- (4) Attach the spinner to the spinner bulkhead with the supplied screws and washers. Refer to Table 3-5.
- (a) When the spinner dome has been removed to facilitate maintenance, check the spinner-to-cylinder fit. If the spinner loosens in service, add one or more layers of UHMW tape to the cylinder until the spinner fits snugly.

APS6179

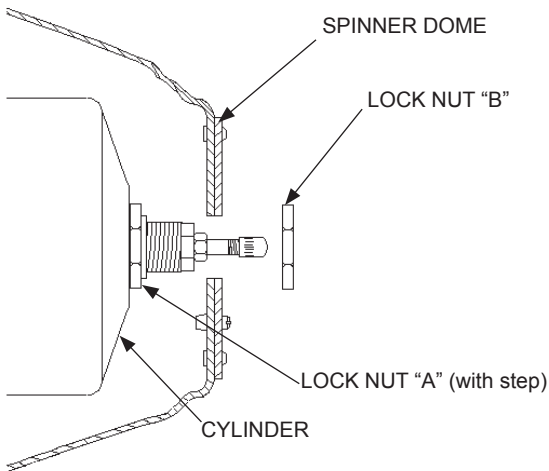

Two-Piece Spinner Mounting (Procedure 1)
Figure 3-8

B. Two-piece Spinner Dome (Procedure 1)**(1) General**

(a) A spinner dome that is installed using Procedure 1 may be identified by the lock nut "A" at the top of the cylinder. The lock nut "A" has a "step" facing away from the cylinder. Refer to Figure 3-8.

1 Lock nut "A" may have drilled holes for safety wire, but safety wire is not required in this location.

(b) The following instructions relate to Hartzell spinners only. In some cases, the airframe manufacturer produced the spinner assembly. Refer to the airframe manufacturer's manual for spinner installation instructions.

(2) Procedure - Refer to Figure 3-8.

(a) Install the spinner dome.

(b) Push the spinner dome toward the bulkhead to align the spinner mounting holes with those of the bulkhead.

(c) Using screws and washers, attach the spinner to the bulkhead or adapter ring. Refer to Table 3-5.

(d) Install the lock nut "B" on the low pitch stop. Refer to Table 3-1 and Figure 3-1 for lock nut torque.

(e) Safety wire the lock nut "B" to each of the two screws on the flat face of the spinner dome surrounding the lock nut "B".

CAUTION: MAKE SURE THAT THE SCREWS DO NOT EXTEND MORE THAN THREE THREADS PAST THE BULKHEAD NUTPLATES. IF THE SCREWS EXTEND MORE THAN THREE THREADS, THIS CAN CAUSE DAMAGE TO THE AIRCRAFT COWLING.

(f) Using flat head screws, attach the spinner dome cap to the spinner dome. Refer to Table 3-5.

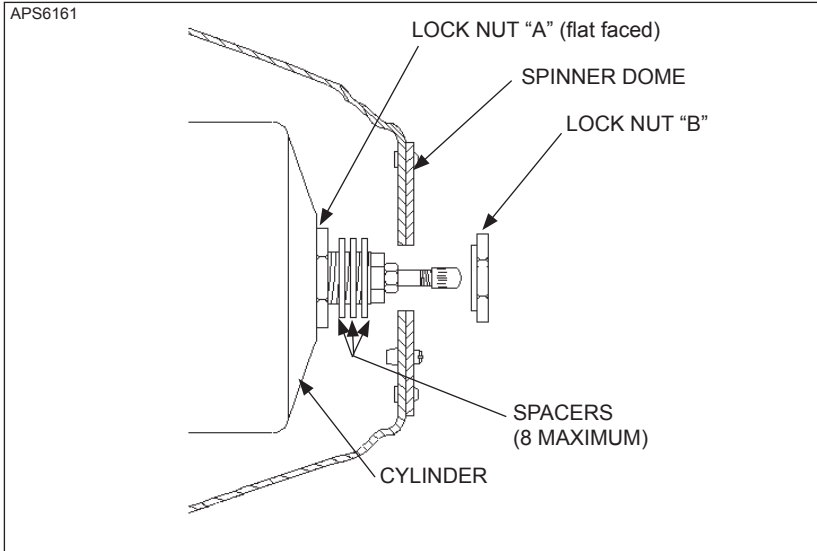

Two-Piece Spinner Mounting (Procedure 2)
Figure 3-9

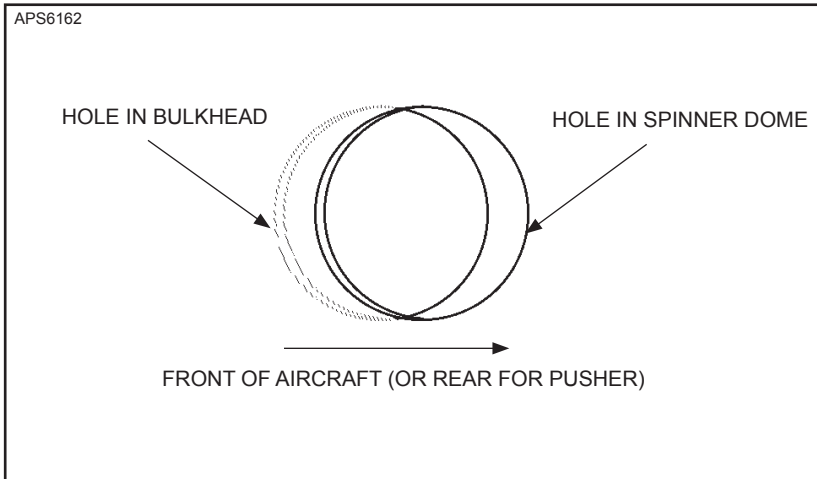

Spinner Dome-to-Bulkhead Mounting Hole Alignment
Figure 3-10

C. Two-Piece Spinner Dome (Procedure 2)**(1) General**

(a) A spinner dome that is installed using Procedure 2 may be identified by the lock nut "A" at the top of the cylinder. The lock nut "A" is flat-faced. Refer to Figure 3-9.

1 Lock nut "A" may have drilled holes for safety wire, but safety wire is not required in this location.

(b) The following instructions relate to Hartzell spinners only. In some cases, the airframe manufacturer produced the spinner assembly. If so, refer to the airframe manufacturer's manual for spinner installation instructions.

(2) Procedure - Refer to Figure 3-9.

(a) Put spacers on the low pitch stop lock nut "A". Up to eight spacers may be used.

(b) Install spacers, then examine the spinner fit. The spinner is correctly spaced when the holes in the spinner dome are misaligned 1/4-1/3 of their diameter toward the front of the aircraft, or rear in a pusher installation. Refer to Figure 3-10. Add or remove spacers to achieve this alignment.

(c) Install the spinner dome.

(d) Push the spinner dome aft to align the spinner mounting holes with those of the bulkhead or adapter ring.

CAUTION: MAKE SURE THAT THE SCREWS DO NOT EXTEND MORE THAN THREE THREADS PAST THE BULKHEAD NUTPLATES. IF THE SCREWS EXTEND MORE THAN THREE THREADS, THIS CAN CAUSE DAMAGE TO THE AIRCRAFT COWLING.

(e) Using screws and washers, attach the spinner to the bulkhead or adapter ring. Refer to Table 3-5.

(f) Install the lock nut "B" (that has a shoulder and safety wire holes) on the low pitch stop. Refer to Table 3-1 and Figure 3-1 for lock nut torque.

- (g) Safety wire the lock nut “B” to each of the two screws on the flat face of the spinner dome surrounding the lock nut “B”.
- (h) Using flat head screws, attach the spinner dome cap to the spinner dome. Refer to Table 3-5.

6. Post-Installation Checks

Perform Static RPM Check as outlined in the Maintenance Practices chapter in this manual.

7. Spinner Removal

CAUTION: WRAP THE BLADE SHANKS IN SEVERAL LAYERS OF MASKING OR DUCT TAPE BEFORE REMOVING THE SPINNER DOME, TO PREVENT DAMAGING THE BLADE AND BLADE SURFACE.

A. Removal of Single Piece Spinner

- (1) Remove the screws and washers that attach the spinner to the spinner bulkhead or adapter ring.
- (2) Remove the spinner dome.

B. Removal of Two-Piece Spinner

- (1) Remove the flat head screws that attach the spinner dome cap to the spinner dome.
- (2) Cut and remove the lock nut safety wire.
- (3) Remove the lock nut.
- (4) Remove the screws and washers that attach the spinner dome to the spinner bulkhead.
- (5) Remove the spinner dome.

C. Hub Mounted Spinner Bulkhead Removal

- (1) Remove the propeller. Refer to Propeller Removal in this chapter.
- (2) Remove the flat washers and self-locking nuts that attach the spinner bulkhead to the propeller hub. Remove the spinner bulkhead.
- (3) Reinstall the flat washers and self-locking nuts that were removed during the removal of the spinner bulkhead.

D. Starter Ring Gear Spinner Adapter Removal

- (1) Remove the propeller. Refer to Propeller Removal in this chapter.
- (2) Remove the spinner adapter by removing the hardware that attaches the spinner adapter to the starter ring gear.

8. Propeller Removal**A. Removal of "F" Flange Propellers**

- (1) Remove the spinner dome in accordance with the section "Spinner Removal" in this chapter.
- (2) If the propeller is equipped with an ice protection system that uses components supplied by Hartzell Propeller Inc., applicable instructions and technical information for the components supplied by Hartzell can be found in the following publications available on the Hartzell website at www.hartzellprop.com:
 - (a) Manual 180 (30-61-80) - Propeller Ice Protection System Manual
 - (b) Manual 181 (30-60-81) - Propeller Ice Protection System Component Maintenance Manual
 - (c) Manual 182 (61-12-82) - Propeller Electrical De-ice Boot Removal and Installation Manual
 - (d) Manual 183 (61-12-83) - Propeller Anti-icing Boot Removal and Installation Manual
- (3) Propeller ice protection system components not supplied by Hartzell Propeller Inc. are controlled by the applicable TC or STC holder's Instructions for Continued Airworthiness (ICA).
- (4) Cut and remove the safety wire (if installed) on the propeller mounting studs.

WARNING: MAKE SURE THE SLING IS RATED UP TO 800 POUNDS (363 KG) TO SUPPORT THE WEIGHT OF THE PROPELLER ASSEMBLY DURING REMOVAL.

- (5) Support the propeller assembly with a sling.

NOTE: Supporting the propeller with the sling may be delayed until all but two mounting nuts and spacers have been removed.

- (6) If the propeller will be reinstalled and it has been dynamically balanced, make an identifying mark (with a felt-tipped pen only) on the propeller hub and a matching mark on the engine flange to make sure of correct positioning of the propeller during re-installation. This will prevent dynamic imbalance.

CAUTION: DISCARD THE PROPELLER MOUNTING NUTS AND SPACERS IF THEY ARE DAMAGED OR CORRODED, OR WHEN THE PROPELLER IS REMOVED FOR OVERHAUL.

- (7) Remove the six 1/2 inch diameter mounting nuts.
- (a) If the propeller is removed between overhaul intervals, mounting studs, nuts, and spacers may be reused if they are not damaged or corroded.

CAUTION: REMOVE THE PROPELLER FROM THE MOUNTING FLANGE WITH CARE TO PREVENT DAMAGING THE PROPELLER MOUNTING STUDS.

- (8) Using the support sling, remove the propeller from the mounting flange.
- (9) Put the propeller on a cart for transport.

- B. Removal of "R" Flange Propellers
- (1) Remove the spinner dome in accordance with the section "Spinner Removal" in this chapter.
 - (2) If the propeller is equipped with an ice protection system that uses components supplied by Hartzell Propeller Inc., applicable instructions and technical information for the components supplied by Hartzell can be found in the following publications available on the Hartzell website at www.hartzellprop.com:
 - (a) Manual 180 (30-61-80) - Propeller Ice Protection System Manual
 - (b) Manual 181 (30-60-81) - Propeller Ice Protection System Component Maintenance Manual
 - (c) Manual 182 (61-12-82) - Propeller Electrical De-ice Boot Removal and Installation Manual
 - (d) Manual 183 (61-12-83) - Propeller Anti-icing Boot Removal and Installation Manual
 - (3) Propeller ice protection system components not supplied by Hartzell Propeller Inc. are controlled by the applicable TC or STC holder's Instructions for Continued Airworthiness (ICA).
 - (4) Cut and remove the safety wire (if installed) on the propeller mounting stud nuts.

WARNING: MAKE SURE THE SLING IS RATED UP TO 800 POUNDS TO SUPPORT THE WEIGHT OF THE PROPELLER ASSEMBLY DURING REMOVAL.

- (5) Support the propeller assembly with a sling.
- (6) If the propeller will be reinstalled and it has been dynamically balanced, make an identifying mark (with a felt-tipped pen only) on the propeller hub and a matching mark on the engine flange to make sure of correct positioning of the propeller during re-installation. This will prevent dynamic imbalance.

CAUTION: DISCARD THE PROPELLER MOUNTING NUTS AND SPACERS IF THEY ARE DAMAGED OR CORRODED, OR WHEN THE PROPELLER IS REMOVED FOR OVERHAUL.

- (7) Unscrew the six 1/2 inch diameter mounting studs from the engine bushings.
 - (a) If the propeller is removed between overhaul intervals, mounting studs, nuts, and spacers may be reused if they are not damaged or corroded.

CAUTION: REMOVE THE PROPELLER FROM THE MOUNTING FLANGE WITH CARE TO PREVENT DAMAGING THE PROPELLER MOUNTING STUDS.

- (8) Using the support sling, remove the propeller from the mounting flange.
- (9) Put the propeller on a cart for transport.

TESTING AND TROUBLESHOOTING - CONTENTS

1. Operational Tests.....	4-3
A. Initial Run-Up	4-3
B. Static RPM Check.....	4-3
C. Post-Run Check.....	4-4
2. Propeller Ice Protection Systems	4-5
A. Electric De-Ice System.....	4-5
B. Anti-Ice System.....	4-5
3. Troubleshooting	4-6
A. Hunting and Surging	4-6
B. Engine Speed Varies with Flight Attitude (or Airspeed).....	4-6
C. Loss of Propeller Control (-1 propellers only)	4-8
D. Loss of Propeller Control (-2 and -4 propellers).....	4-8
E. Failure to Feather or Feathers Slowly (-2 propellers only)....	4-9
F. Failure to Unfeather (-2 propellers only)	4-9
G. Start Locks (Anti-feather Latches) Fail to Latch on Shutdown (-2 propellers only)	4-10
H. Vibration.....	4-11
I. Propeller Overspeed	4-12
J. Overspeed Avoidance (Operational) for Propeller Models HC-() (2,3)Y() ()-1().....	4-13
K. Overspeed Avoidance (Mechanical Modification) for Propeller Models HC-() (2,3)Y() ()-1().....	4-13
L. Propeller Underspeed	4-14
M. Oil or Grease Leakage.....	4-14

(This page is intentionally blank.)

1. Operational Tests

Following propeller installation, and before every flight, the propeller system must be purged of air and proper operation verified.

A. Initial Run-Up

- (1) Perform engine start and warm-up per the Pilot's Operating Handbook (POH).

CAUTION: AIR TRAPPED IN THE PROPELLER HYDRAULIC SYSTEM WILL CAUSE THE PITCH CONTROL TO BE IMPRECISE AND MAY RESULT IN PROPELLER SURGING.

- (2) Cycle the propeller control throughout its operating range from low to high (or as directed by the POH).
- (3) Repeat this procedure at least three times to purge air from the propeller hydraulic system and to introduce warmed oil to the cylinder.

NOTE: Pitch change response on the first operation from low to high blade pitch may be slow, but should speed up on the second and third cycles

- (4) Verify proper operation from low pitch to high pitch and throughout operating range.
- (5) Shut down the engine in accordance with the POH.

B. Static RPM Check

NOTE: This operational check should be performed after installation, maintenance, or propeller adjustment.

CAUTION: A CALIBRATED TACHOMETER MUST BE USED TO MAKE SURE OF THE ACCURACY OF THE RPM CHECK.

- (1) Set the brakes and chock the aircraft or tie aircraft down.
- (2) Back the governor Maximum RPM Stop out one turn.
- (3) Start the engine.
- (4) Advance the propeller control lever to MAX (max RPM), then retard the control lever one inch (25.4 mm).
- (5) SLOWLY advance the throttle to maximum manifold pressure.

- (6) Slowly advance the propeller control lever until the engine speed stabilizes.
 - (a) If engine speed stabilizes at the maximum RPM specified by the TC or STC holder, then the low pitch stop is set correctly.
 - (b) If engine speed stabilizes above or below the rated RPM, the low pitch stop may require adjustment. Refer to the Maintenance Practices chapter of this manual.
- (7) Stop the engine.
- (8) Return the governor Maximum RPM Stop to the original position, or adjust the governor to the rated RPM with the Maximum RPM Stop screw.

WARNING: REFER TO THE AIRCRAFT MAINTENANCE MANUAL FOR ADDITIONAL PROCEDURES THAT MAY BE REQUIRED AFTER PROPELLER INSTALLATION.

C. Post-Run Check

- (1) After engine shutdown, check the propeller for signs of engine oil leakage.

2. Propeller Ice Protection Systems**A. Electric De-ice System**

- (1) Consult the Pilot Operating Handbook (including all supplements) regarding flight into conditions of known icing. The aircraft may not be certificated for flight in known icing conditions, even though propeller de-ice equipment is installed.
- (2) Refer to the Anti-ice and De-ice Systems Chapter of this manual for functional tests of the de-ice system.

B. Anti-ice System

- (1) Consult the Pilot Operating Handbook (including all supplements) regarding flight into conditions of known icing. The aircraft may not be certificated for flight in known icing conditions, even though propeller anti-ice equipment is installed.
- (2) Refer to the Anti-ice and De-ice Systems Chapter of this manual for functional tests of the anti-ice system.

3. Troubleshooting**A. Hunting and Surging**

Hunting is characterized by a cyclic variation in engine speed above and below desired speed. Surging is characterized by a large increase/decrease in engine speed, followed by a return to set speed after one or two occurrences.

(1) If the propeller is hunting, a repair facility should check:

- (a) Governor
- (b) Fuel control
- (c) Synchrophaser or synchronizer.

(2) If the propeller is surging:

Perform Steps 1.A. (1)-(5) under "Operational Tests," in this chapter. If surging recurs, it is most likely due to a faulty governor. Have the governor tested at an appropriately licensed propeller repair facility.

(3) Hunting and/or surging may also be caused by friction or binding within the governor control, or by internal propeller corrosion, which causes the propeller to react slower to governor commands. The propeller must be tested at an appropriately licensed propeller repair facility to isolate these faults.

B. Engine Speed Varies with Flight Attitude (or Airspeed)

(1) Small variances in engine speed are normal and are no cause for concern.

(2) Increase in engine speed while descending or increasing airspeed:

(a) Non-feathering (-1) propeller:

- 1 Governor is not increasing oil volume in the propeller.
- 2 Engine transfer bearing leaking excessively.
- 3 Excessive friction in the blade bearings or pitch changing mechanism.
- 4 Accumulator air pressure is too low.

- (b) Feathering (-2) or Aerobatic (-4) propeller:
 - 1 Governor is not reducing oil volume in the propeller.
 - 2 Air charge (-2 propeller only) is too low. Refer to the Maintenance Practices chapter for air recharge procedure.
 - 3 Excessive friction in the blade bearings or pitch changing mechanism.
- (3) Decrease in engine speed while increasing airspeed:
 - (a) Non-feathering (-1) propeller:
 - 1 Governor pilot valve is stuck and is excessively increasing oil volume.
 - (b) Feathering (-2) or Aerobatic (-4) propeller:
 - 1 Governor pilot valve is stuck and is excessively decreasing oil volume.
 - 2 Feathering command engaged on propeller pitch control (-2 propeller only).
- (4) Increase in engine speed while decreasing airspeed:
 - (a) Non-feathering (-1) propeller:
 - 1 Governor pilot valve is stuck and is excessively decreasing oil volume.
 - (b) Feathering (-2) or Aerobatic (-4) propeller:
 - 1 Governor pilot valve is stuck and is excessively increasing oil volume.
- (5) Decrease in engine speed while decreasing airspeed:
 - (a) Non-feathering (-1) propeller:
 - 1 Governor is not reducing oil volume in propeller.
 - 2 Excessive friction in blade bearings or pitch changing mechanism.
 - (b) Feathering (-2) or Aerobatic (-4) propeller:
 - 1 Governor is not increasing oil volume in the propeller.
 - 2 Air charge (-2 propeller only) is too high. Refer to the Maintenance Practices chapter for air recharge procedure.
 - 3 Engine transfer bearing leaking excessively.
 - 4 Excessive friction in the blade bearings or pitch changing mechanism.

- C. Loss of Propeller Control (-1 propellers only)
- (1) Propeller goes to uncommanded low pitch (high RPM)
 - (a) Loss of propeller oil pressure - Check:
 - 1 Governor pressure relief valve for proper operation.
 - 2 Governor drive for damage.
 - 3 Adequate engine oil supply.
 - 4 Engine transfer bearing leaking excessively.
 - 5 Accumulator air pressure is too low.
 - (b) Internal oil leakage to opposite side of piston and into hub.
 - (2) Propeller goes to uncommanded high pitch (low RPM)
Governor pilot valve sticking.
 - (3) RPM increases with power and airspeed, propeller RPM control has little or no effect.
 - (a) Excessive friction in the blade bearings or pitch changing mechanism.
 - (b) Internal oil leakage to opposite side of piston and into hub.
- D. Loss of Propeller Control (-2 and -4 propellers)
- (1) Propeller goes to uncommanded high pitch (or feather)
 - (a) Loss of propeller oil pressure - check:
 - 1 Governor pressure relief valve for proper operation.
 - 2 Governor drive for damage.
 - 3 Adequate engine oil supply.
 - 4 Engine transfer bearing leaking excessively.
 - (b) Start locks not engaging (-2 propellers only)
 - (c) Air charge pressure too high (-2 propellers only).
Refer to the Maintenance Practices chapter for air recharge procedure.
 - (2) Propeller goes to uncommanded low pitch (high RPM)
 - (a) Governor pilot valve sticking.

- (3) RPM increases with power and airspeed, propeller RPM control has little or no effect.
 - (a) Excessive friction in blade bearings or pitch changing mechanism.
 - (b) Air charge lost or low. (-2 propellers only). Refer to the Air Charge section in the Maintenance Practices chapter of this manual.
 - (c) Broken feathering spring (-2 propellers only).
- (4) RPM Control Sluggish
 - (a) Air charge lost or low (-2 propellers only). Refer to the Air Charge section in the Maintenance Practices chapter of this manual.
- E. Failure to Feather or Feathers Slowly (-2 propellers only)
 - (1) Air charge lost or low. Refer to the Air Charge section in the Maintenance Practices chapter of this manual.
 - (2) Check for proper function and rigging of propeller/governor control linkage.
 - (3) Check governor drain function.
 - (4) Check the propeller for misadjustment or internal corrosion (usually in blade bearings or pitch change mechanism) that results in excessive friction. This check must be performed at an appropriately licensed propeller repair facility.
- F. Failure to Unfeather (-2 propellers only)
 - (1) Check for proper function and rigging of propeller control linkage.
 - (2) Perform a check of the governor function.
 - (3) Check for excessive oil leakage at engine transfer bearing.
 - (4) Check the propeller for misadjustment or internal corrosion (usually in blade bearings or pitch change mechanism) that results in excessive friction. This check must be performed at an appropriately licensed propeller repair facility.

- G. Start Locks (Anti-feather Latches) Fail to Latch on Shutdown (-2 propellers only)
- (1) Propeller was feathered before shutdown.
 - (2) Shutdown occurred at high RPM with prop control off the low pitch stop.
 - (3) Air charge is too high. Refer to the Maintenance Practices chapter for this procedure.
 - (4) Excessive engine transfer bearing oil leakage.
 - (5) Excessive governor pump leakage.
 - (6) Broken start locks.

Problems G(1) and G(2) above may be solved by restarting the engine, placing the propeller control in the proper shutdown position, and then shutting down the engine.

Problems G(4), G(5), and G(6) should be referred to an appropriately licensed propeller repair facility.

H. Vibration

CAUTION 1: ANY VIBRATION THAT OCCUR SUDDENLY, OR IS ACCOMPANIED BY UNEXPLAINED GREASE LEAKAGE SHOULD BE INVESTIGATED IMMEDIATELY BEFORE FURTHER FLIGHT.

CAUTION 2: VIBRATION PROBLEMS BECAUSE OF PROPELLER SYSTEM IMBALANCE ARE NORMALLY FELT THROUGHOUT THE RPM RANGE, WITH THE INTENSITY OF VIBRATION INCREASING WITH RPM. VIBRATION PROBLEMS THAT OCCUR IN A NARROW RPM RANGE ARE A SYMPTOM OF RESONANCE, THAT IS POTENTIALLY HARMFUL TO THE PROPELLER. AVOID OPERATION UNTIL THE PROPELLER CAN BE CHECKED AT AN APPROPRIATELY LICENSED REPAIR FACILITY.

(1) Check:

- (a) Control surfaces, cowl flaps, exhaust system, landing gear doors, etc. for excessive play that may be causing vibration that is unrelated to the propeller.
- (b) Isolation of engine controls and lines.
- (c) Engine mount wear.
- (d) Uneven or over lubrication of propeller.
- (e) Proper engine/propeller flange mating.
- (f) Blade track. Refer to Blade Track in the Inspection and Check chapter of this manual.
- (g) Blade angles: Blade angle must be within tolerance between blades and on the propeller as a whole. Refer to the applicable propeller overhaul manual for blade angle check procedure.
- (h) Spinner for cracks, improper installation, or "wobble" during operation.
- (i) Static balance.

- (j) Propeller installation - remove and reinstall the propeller 180 degrees from the original installation position.
 - 1 "R" flange propellers installed on an R engine flange cannot be reinstalled 180 degrees from original installation position.
- (k) Hub damage or cracking.
- (l) Grease or oil leakage.
- (m) Blade deformation.

NOTE: Dynamic balancing is recommended after installation of or performing maintenance on a propeller. While normally an optional task, it may be required by the engine or airframe manufacturer to make certain the propeller/engine combination is balanced correctly before operation. Refer to the engine or airframe manuals, and the Maintenance Practices chapter of this manual.

I. Propeller Overspeed

(1) Check:

- (a) Tachometer error.
- (b) Low pitch stop adjustment.
- (c) Governor Maximum RPM set too high.
- (d) Loss of oil pressure (-1 propellers only)
 - 1 Oil starvation
 - 2 Governor failure
 - 3 Accumulator air pressure low
- (e) Loss or lowered air charge (-2 propellers only-results in momentary overspeed). Refer to the Air Charge section in the Maintenance Practices chapter of this manual.
- (f) Governor pilot valve jammed to supply high pressure only. (-2 and -4 propellers only)
- (g) Oil leaking past piston causing the hydraulic lock of piston in the cylinder. (-1 propellers only)

J. Overspeed Avoidance (Operational) for Propeller Models ()HC-()(2,3)Y()()-1()

- (1) Hartzell ()HC-()(2,3)Y()()-1() propellers are designed to reduce blade angle in the event of a loss of oil pressure. This reduction in blade angle allows all available engine power to be utilized in the event of an oil system failure. This reduction in blade angle also can allow the engine to overspeed, especially at higher airspeeds. During most aerobatic maneuvers, overspeeds are prevented by an accumulator system that supplies back-up oil pressure for a limited time.
- (2) If the aircraft is capable of performing maneuvers that result in an extended loss of oil pressure to the propeller governor, the back-up supply of the accumulator can be exhausted. To prevent engine overspeeds during extended maneuvers that result in a loss of oil pressure, reduce the power and/or check to ensure that engine oil pressure has been restored before re-applying power.
- (3) Additional information regarding the momentary loss of oil pressure during aerobatic flight can be found in the Christen 801 Series Inverted Oil System Product Manual.

K. Overspeed Avoidance (Mechanical Modification) for Propeller Models ()HC-()(2,3)Y()()-1()

- (1) If maneuvers are regularly performed that could result in engine overspeeds, an alternate means of overspeed protection is available by modifying the propeller such that it defaults to high pitch blade angle in the event of a loss of oil pressure. This modification uses blade counterweights, an oil-to-decrease pitch governor, and eliminates the use of the accumulator.
- (2) If this modification is used, it should be understood that while supplying protection from overspeeds, this propeller system will not permit the use of all available engine power in the event of an oil system failure. The modification is available for certain applications. Refer to Hartzell Service Bulletin HC-SB-61-240 for details about this modification.
- (3) If there is an engine overspeed, refer to the Inspection and Check chapter of this manual for corrective action following a propeller overspeed. Additional inspections may be required by the engine and/airframe manufacturer.

L. Propeller Underspeed**(1) Check:**

- (a) Tachometer error.
- (b) Excessive transfer bearing oil leakage.
- (c) Governor oil pressure low.
- (d) Governor oil passage clogged.
- (e) Oil leaking past piston causing hydraulic lock in the cylinder (-2 and -4 propellers only).

M. Oil or Grease Leakage

NOTE: A new propeller may leak slightly during the first several hours of operation. This leakage may be caused by the seating of seals and O-rings, and the slinging of lubricants used during assembly. Such leakage should cease within the first ten hours of operation.

CAUTION: GREASE LEAKAGE THAT CAN BE DESCRIBED AS EXCESSIVE AND APPEARING SUDDENLY, ESPECIALLY WHEN ACCOMPANIED BY VIBRATION SHOULD BE INVESTIGATED IMMEDIATELY BEFORE FURTHER FLIGHT.

(1) Check for:

- (a) Improperly torqued or loose lubrication fitting.
- (b) Defective lubrication fitting.
- (c) Damaged blade shank O-ring seal.
- (d) Damaged hub seal (at hub parting line).
- (e) Damaged engine transfer O-ring at hub/engine flange interface.
- (f) Cracked hub. A cracked hub is often indicated by grease emerging from a seemingly solid surface.

INSPECTION AND CHECK- CONTENTS

1. Pre-Flight Checks	5-3
2. Operational Checks	5-5
3. Required Periodic Inspections and Maintenance	5-6
A. Periodic Inspections	5-6
B. Periodic Maintenance	5-8
C. Airworthiness Limitations	5-8
D. Overhaul Periods	5-9
4. Inspection Procedures	5-11
A. Blade Damage	5-11
B. Grease or Oil Leakage	5-11
C. Vibration	5-13
D. Tachometer Inspection	5-15
E. Blade Track	5-16
F. Loose Blades	5-17
G. Corrosion	5-18
H. Spinner Damage	5-18
I. Accumulator	5-18
J. Electric De-Ice System	5-18
K. Anti-ice System	5-18
5. Special Inspections	5-20
A. Overspeed/Overtorque	5-20
B. Lightning Strike	5-21
C. Foreign Object Strike/Ground Strike	5-23
D. Fire Damage or Heat Damage	5-25
6. Long Term Storage	5-25

LIST OF FIGURES

Checking Blade Track	Figure 5-1	5-16
Blade Play	Figure 5-2	5-17
Reciprocating Engine Overspeed Limits	Figure 5-3	5-19

(This page is intentionally blank.)

1. Pre-Flight Checks

Follow propeller preflight inspection procedures as specified in the Pilot Operating Handbook (POH). In addition, perform the following inspections:

A. Blades

- (1) Visually inspect the entire blade for nicks, gouges, erosion, and cracks. Refer to the Maintenance Practices chapter of this manual, for blade repair information.
- (2) Visually inspect the blades for lightning strike. Refer to the Lightning Strike Damage section in this chapter for a description of damage.

CAUTION 1: FAILURE TO INSTALL THE EROSION TAPE CM158 ON AN N7605-() OR AN N7605C-() NON-BOOTED BLADE THAT DOES NOT HAVE A DE-ICE BOOT INSTALLED WILL CAUSE THE INBOARD LEADING EDGE OF THE BLADE TO ERODE PREMATURELY.

CAUTION 2: DO NOT INSTALL EROSION TAPE CM158 ON AN N7605B-() OR AN N7605CB-() BLADE. THE N7605B-() AND N7605CB-() BLADES USE AN ALCOHOL ANTI-ICE BOOT. INSTALLATION OF EROSION TAPE CM158 WILL PREVENT PROPER FUNCTION OF THE ANTI-ICE BOOT.

- (3) An N7605-() or an N7605C-() blade that will not have an anti-icing boot installed must have erosion tape CM158 installed on the leading edge. Refer to the Maintenance Practices chapter of this manual, for erosion tape installation instructions.

- B. Inspect the spinner and visible blade retention components for damage or cracks. Repair or replace components as required before further flight.
- C. Check for loose or missing hardware. Retighten or reinstall as necessary.

WARNING: ABNORMAL GREASE LEAKAGE CAN BE AN INDICATION OF A FAILING PROPELLER BLADE OR BLADE RETENTION COMPONENT. AN IN-FLIGHT BLADE SEPARATION CAN RESULT IN A CATASTROPHIC AIRCRAFT ACCIDENT.

D. Inspect for grease and oil leakage and determine its source.

WARNING: ABNORMAL VIBRATION CAN BE AN INDICATION OF A FAILING PROPELLER BLADE OR BLADE RETENTION COMPONENT. AN IN-FLIGHT BLADE SEPARATION CAN RESULT IN A CATASTROPHIC AIRCRAFT ACCIDENT.

- E. Check the blades for radial play or movement of the blade tip (in and out, fore and aft, and end play). Refer to Loose Blades, in the Periodic Inspections section of this chapter, for blade play limits.
- F. Inspect the the anti-icing or de-ice boots (if installed) for damage. Refer to the Anti-ice and De-ice Systems chapter of this manual, for inspection information.
- G. Refer to the Periodic Inspections section in this chapter for additional inspection information and possible corrections to any discrepancies discovered as a result of preflight checks.

2. Operational Checks

- A. Following propeller installation and before flight, perform initial run-up as outlined in Operational Tests in the Testing and Troubleshooting chapter of this manual.
- B. Check the propeller speed control and operation from reverse or low pitch to high pitch, using the procedure specified in the Pilot Operating Handbook (POH) for the aircraft.
 - (1) Perform all ground functional, feathering, and cycling checks with the minimum propeller RPM drop required to demonstrate function.
 - (2) A typical RPM drop is 300-500 RPM for feathering propellers and 100 to 300 RPM for non-feathering propellers.

WARNING: ABNORMAL VIBRATION CAN BE AN INDICATION OF A FAILING PROPELLER BLADE OR BLADE RETENTION COMPONENT. AN INFLIGHT BLADE SEPARATION MAY RESULT IN DEATH, SERIOUS BODILY INJURY, AND/OR SUBSTANTIAL PROPERTY DAMAGE.

- C. Check for any abnormal vibration during this run-up. If vibration occurs, shut the engine down, determine the cause, and correct it before further flight. Refer to the Vibration section in the Testing and Troubleshooting chapter of this manual.
- D. Refer to Periodic Inspections in this chapter for additional inspection information and possible corrections to any discrepancies discovered as a result of Pre-Flight Checks.
- E. Refer to the airframe manufacturer's manual for additional operational checks.

3. Required Periodic Inspections and Maintenance

Perform detailed inspection procedures at 100 hour intervals, not to exceed twelve (12) calendar months. Procedures involved in these inspections are detailed below.

A. Periodic Inspections

NOTE 1: Inspection and maintenance specified by an airframe manufacturer's maintenance program and approved by the applicable airworthiness agency may not coincide with the inspection time intervals specified. In this situation, the airframe manufacturer's schedule may be applied with the exception that the calendar limit for the inspection interval may not exceed twelve (12) months.

NOTE 2: Refer to Inspection Procedures in this chapter for additional inspection information and possible corrections to any discrepancies discovered as a result of the Periodic Inspection.

(1) Remove the spinner dome.

CAUTION: DO NOT ATTEMPT TO REPAIR A
CRACKED BLADE.

(2) Visually inspect the blades for nicks, gouges, and cracks. Refer to the Maintenance Practices chapter of this manual for procedure. If any damage is discovered, refer to the Blade Repairs section in the Maintenance Practices chapter of this manual for additional information. A cracked blade must be referred to an appropriately licensed propeller repair station.

CAUTION: DO NOT ATTEMPT TO REPAIR A
CRACKED HUB.

(3) Visually inspect the hub parts for cracks or wear. Refer to Grease and Oil Leaks in the Inspection Procedures section of this chapter for procedure. A cracked hub must be referred to an appropriately licensed propeller repair facility.

(4) Inspect all visible propeller parts for cracks, wear or unsafe conditions.

(5) Check for oil and grease leaks. Refer to Grease and Oil Leaks in the Inspection Procedures section of this chapter for procedure.

- (6) If a blade track problem is suspected, check the blade track. Refer to Blade Track in the Inspection Procedures section of this chapter.
- (7) For Hartzell composite propeller blade models ()7690(), ()7890(), and ()7421() installed on an undampened or modified Lycoming (AE)IO-360 engine, perform a visual on-wing inspection of the blade shank every 50 flight hours. Refer to the On Wing Blade Shank Inspection section in the Maintenance Practices chapter of this manual.
 - (a) For the purposes of this inspection, “modified” refers to engines that have had changes that may effect the vibratory characteristics of the engine such as, but not limited to, increased compression ratio, changes to boost horsepower, aftermarket turbo chargers, running at higher than rated RPM, and removing dampeners.
- (8) For (-2) feathering propellers that incorporate an air charge in the cylinder, check pressure every 100 hours or once a month, whichever comes first. Refer to the Maintenance Practices chapter of this manual for procedures.
 - (a) If the propeller air pressure is routinely low, or there is engine oil leaking from the air valve, the cause may be a faulty seal in the propeller. An inspection to verify the condition of the seal should be performed by qualified personnel at an appropriately licensed propeller repair facility.
- (9) Check the accuracy of the tachometer. Refer to the Tachometer Inspection section in the Inspection Procedures section of this chapter.
- (10) Examine the accumulator for a label that shows the part number 8907-040. Refer to the Accumulator Part Number Change section in the Maintenance Practices chapter of this manual for the procedure to change the accumulator labels.
- (11) Clean or replace the anti-ice system filter (if an anti-ice system is installed).
- (12) Make an entry in the propeller logbook about completion of these inspections.

B. Periodic Maintenance

- (1) Lubricate the propeller assembly. Refer to the Lubrication section in the Maintenance Practices chapter of this manual for intervals and procedures.

C. Airworthiness Limitations

- (1) Certain components, as well as the entire propeller may have specific life limits established as part of the certification by the FAA. Such limits require mandatory replacement of specified parts after a defined number of hours and/or cycles of use.
- (2) Life limited component times may exist for the propeller models included in this manual. Refer to the Airworthiness Limitations chapter of this manual.
- (3) Operators are urged to keep informed of airworthiness information via Hartzell Service Bulletins and Service Letters, which are available from Hartzell distributors or from the Hartzell factory by subscription. Selected information is also available on the Hartzell Propeller Inc. website at www.hartzellprop.com.

D. Overhaul Periods

In flight, the propeller is constantly subjected to vibration from the engine and the airstream, as well as high centrifugal forces. The propeller is also subject to corrosion, wear, and general deterioration due to aging. Under these conditions, metal fatigue or mechanical failures can occur. In order to protect your safety, your investment, and to maximize the safe operating lifetime of your propeller, it is essential that a propeller be properly maintained and overhauled according to the recommended service procedures.

CAUTION 1: OVERHAUL PERIODS LISTED BELOW, ALTHOUGH CURRENT AT THE TIME OF PUBLICATION, ARE FOR REFERENCE PURPOSES ONLY. OVERHAUL PERIODS MAY BE INCREASED OR DECREASED AS A RESULT OF EVALUATION.

CAUTION 2: CHECK THE LATEST REVISION OF HARTZELL SERVICE LETTER HC-SL-61-61Y FOR THE MOST CURRENT INFORMATION. THE SERVICE LETTER IS AVAILABLE ON THE HARTZELL PROPELLER INC. WEBSITE AT www.hartzellprop.com.

- (1) Propellers installed on piston engine **aerobatic aircraft** (certificated as aerobatic or other aircraft routinely exposed to aerobatic use) must be overhauled at 1000 hours. See paragraph 3.D.(8) for calender limits.
- (2) Propellers installed on **agricultural aircraft** must be overhauled at 2000 hours. Calendar time is limited to 36 months. These limits apply even if the propeller is later installed on a non-agricultural category aircraft.
- (3) Propellers installed on Franklin engines must be overhauled at 1500 hours. Refer to paragraph 3.D.(8) for calender limits.
- (4) Two blade propellers manufactured **before** April 1997 must be overhauled at 2000 hours. Refer to paragraph 3.D.(8) for calender limits.

- (5) Two blade propellers manufactured **after** April 1997 (identified by a "B" suffix in the propeller serial number) must be overhauled at 2400 hours. Calendar time is limited to 72 months.
- (6) Three blade propellers manufactured **before** 1983 must be overhauled at 2000 hours. Refer to paragraph 3.D.(8) for calendar limits.
- (7) Three blade propellers manufactured **after** 1983 must be overhauled at 2400 hours. Refer to paragraph 3.D.(8) for calendar limits.
- (8) Propellers manufactured or overhauled since October 1991 are required to have the internal hub surface painted for additional corrosion protection. Hubs with painted internal surface have a 72 month overhaul calendar limit. Hubs that have not had the internal surface painted have a 60 month overhaul calendar limit until the hub internal surface is painted for corrosion protection. After painting, calendar limit increases to 72 months.

4. Inspection Procedures

The following inspections must be made on a regular basis, either before flight, during required periodic inspection as described in this chapter, or if a problem is noted. Possible corrections to problems discovered during inspections, additional inspections, and limits are detailed in the following inspection procedures.

A. Blade Damage

Refer to the Composite Blade section of the Maintenance Practices chapter of this manual for information regarding blade damage.

B. Grease or Oil Leakage

WARNING: UNUSUAL OR ABNORMAL GREASE LEAKAGE OR VIBRATION, WHERE THE CONDITION INITIATED SUDDENLY, CAN BE AN INDICATION OF A FAILING PROPELLER BLADE OR BLADE RETENTION COMPONENT. AN INFLIGHT BLADE SEPARATION MAY RESULT IN DEATH, SERIOUS BODILY INJURY, AND/OR SUBSTANTIAL PROPERTY DAMAGE. UNUSUAL OR ABNORMAL GREASE LEAKAGE OR VIBRATION DEMANDS IMMEDIATE INSPECTION FOR POSSIBLE CRACKED HUB.

NOTE: A new or newly overhauled propeller may leak slightly during the first several hours of operation. This leakage may be caused by the seating of seals and O-rings, and the slinging of lubricants used for seal lubrication during assembly. Such leakage should cease within the first ten hours of operation.

Leakage that persists beyond the first ten hours of operation on a new or newly overhauled propeller, or occurs on a propeller that has been in service for some time will require repair. A determination should be made as to the source of the leak. The only leakage that is field repairable is the removal and replacement of the O-ring seal between the engine and propeller flange. All other leakage repairs should be referred to an appropriately licensed propeller repair facility. An instance of abnormal grease leakage should be inspected by using the following procedure:

- (1) Remove the spinner dome.

CAUTION: PERFORM A VISUAL INSPECTION WITHOUT CLEANING THE PARTS. A TIGHT CRACK IS OFTEN EVIDENT DUE TO TRACES OF GREASE EMANATING FROM THE CRACK. CLEANING CAN REMOVE SUCH EVIDENCE AND MAKE A CRACK VIRTUALLY IMPOSSIBLE TO SEE.

- (2) Perform a visual inspection for cracks in the hub. A crack may be readily visible, or may be indicated by grease leaking from a seemingly solid surface. Extra attention should be given to the blade retention areas of the hub.
- (3) Perform a visual inspection of the hub and blade retention areas to locate the origin of leakage. If the origin of grease leakage is determined to be a noncritical part such as an O-ring or sealant, repairs can be accomplished during scheduled maintenance, as long as flight safety is not compromised.
- (4) If cracks are suspected, additional inspections must be performed before further flight. These inspections must be performed by qualified personnel at an appropriately licensed propeller repair facility to verify the condition. Such inspections typically include disassembly of the propeller followed by inspection of the parts, using non-destructive methods in accordance with published procedures.
- (5) If cracks or failing components are found, parts must be replaced before further flight. Report such incidents to airworthiness authorities and Hartzell Propeller Inc. Product Support.

C. Vibration

Instances of abnormal vibration should be investigated immediately. If the cause of the vibration is not readily apparent, the propeller may be inspected by following the procedure below:

NOTE: It may be difficult to readily identify the cause of abnormal vibration. It may originate in the engine, propeller, or airframe. Troubleshooting procedures typically initiate with investigation of the engine. Airframe components (such as engine mounts or loose landing gear doors) can also be the source of vibration. When investigating an abnormal vibration, the possibility of a failing blade or blade retention component should be considered as a potential source of the problem.

- (1) Perform troubleshooting and evaluation of possible sources of vibration in accordance with engine or airframe manufacturer's instructions.
- (2) Refer to the Vibration section in the Testing and Troubleshooting chapter of this manual. Perform the checks to determine possible cause of the vibration. If no cause is found, then consider that the origin of the problem could be the propeller and proceed with steps 4.C.(3) through 4.C.(8) in this chapter.
- (3) Remove the spinner dome.
- (4) Perform a visual inspection for cracks in the hub.
 - (a) Pay particular attention to the blade retention areas of the hub.
 - (b) A crack may be readily visible, or may be indicated by grease leaking from a seemingly solid surface.
- (5) If cracks are suspected, additional inspections must be performed before further flight. These inspections must be performed by qualified personnel at an appropriately licensed propeller repair facility to verify the condition. Such inspections typically include disassembly of the propeller, followed by inspection of parts, using nondestructive methods in accordance with published procedures.

- (6) Check the blades and compare blade to blade differences:
 - (a) Inspect the propeller blades for unusual looseness or movement. Refer to the Loose Blade section of this chapter.
 - (b) Check blade track. Refer to the Blade Track section of this chapter.

**CAUTION: DO NOT USE BLADE PADDLES TO
TURN THE BLADES.**

- (c) Manually (by hand) attempt to turn the blades (change pitch).
 - (d) Visually check for damaged blades (delaminations, debonds, cracks, etc.).
- (7) If abnormal blade conditions or damage are found, additional inspections must be performed by an appropriately licensed propeller repair facility to evaluate the condition. Refer to the Composite Blade section in the Maintenance Practices chapter of this manual.
- (8) If cracks or failing components are found, parts must be replaced before further flight. Report such incidents to airworthiness authorities and Hartzell Propeller Inc. Product Support.

D. Tachometer Inspection

WARNING: OPERATION WITH AN INACCURATE TACHOMETER MAY RESULT IN RESTRICTED RPM OPERATION AND DAMAGING HIGH STRESSES. BLADE LIFE WILL BE SHORTENED AND COULD RESULT IN CATASTROPHIC FAILURE.

- (1) Accuracy of the engine tachometer should be verified at 100 hour intervals or at annual inspection, whichever occurs first.
- (2) Hartzell Propeller Inc recommends using a tachometer that is accurate within +/- 10 RPM, has NIST calibration (traceable), and has an appropriate calibration schedule.

E. Blade Track

(1) Check blade track as follows:

- (a) Chock the aircraft wheels securely.
- (b) Refer to Figure 5-1. Place a fixed reference point beneath the propeller, within 0.25 inch (6.00 mm) of the lowest point of the propeller arc.

NOTE: This reference point may be a flat board with a sheet of paper attached to it. The board may then be blocked up to within 0.25 inch (6.00 mm) of the propeller arc.

WARNING: MAKE SURE THAT THE ENGINE MAGNETO IS GROUNDED (OFF) BEFORE ROTATING THE PROPELLER.

- (c) Rotate the propeller by hand (opposite the direction of normal rotation) until a blade points directly at the paper. Mark the position of the blade tip in relation to the paper.
- (d) Repeat this procedure with the remaining blades.
- (e) Tracking tolerance is ± 0.125 inch (± 3.18 mm) or 0.250 inch (6.35 mm) total.

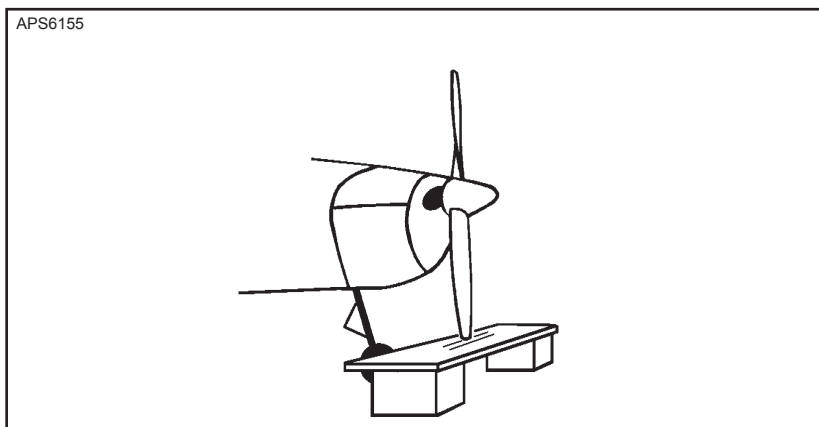

Checking Blade Track
Figure 5-1

(2) Possible Correction

- (a) Remove foreign matter from the propeller mounting flange.
- (b) If no foreign matter is present, refer to an appropriately licensed propeller repair facility.

F. Loose Blades

Refer to Figure 5-2. Limits for blade looseness are as follows:

End Play (leading edge to trailing edge) See Note below

Fore & Aft Movement (Face to camber) See Note below

In & Out

None

Radial Play (pitch change)

± 0.5 degree

(1 degree total)

measured at

reference station

NOTE: Blades are intended to be tight in the propeller, however slight movement is acceptable if the blade returns to its original position when released. Blades with excessive movement, or blades that do not return to their original position when released may indicate internal wear or damage that should be referred to an appropriately licensed propeller repair facility.

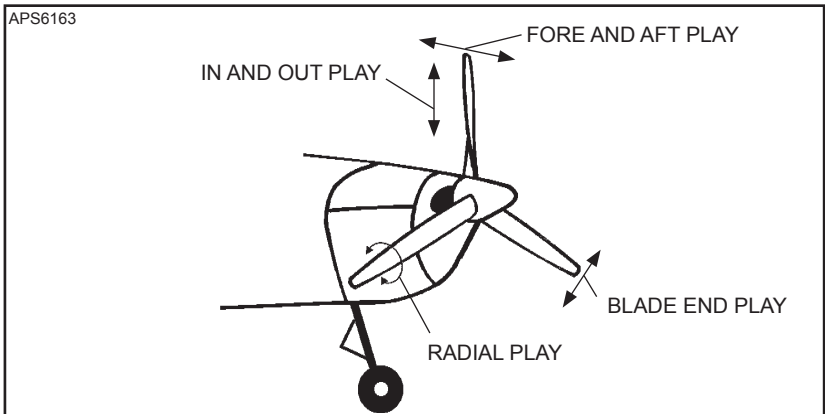

Blade Play
Figure 5-2

G. Corrosion

WARNING: REWORK THAT INVOLVES COLD WORKING THE METAL, RESULTING IN CONCEALMENT OF A DAMAGED AREA, IS NOT PERMITTED.

Light corrosion on the counterweights may be removed by qualified personnel in accordance with the Blade Repairs section in the Maintenance Practices chapter of this manual.

Heavy corrosion that results in severe pitting must be referred to an appropriately licensed propeller repair facility.

H. Spinner Damage

Inspect the spinner for cracks, missing hardware, or other damage. Refer to Hartzell Manual 127 (61-16-27) or an appropriately licensed propeller repair facility for spinner damage acceptance and repair information. Contact the local airworthiness authority for repair approval.

I. Accumulator

- (1) Check the accumulator air charge at 50 flight hours or six (6) months, whichever occurs first.
- (2) Using dry air or nitrogen, charge the accumulator at 15 to 25 psi (103.4 to 172.4 kPa).

J. Electric De-ice System

Refer to the Anti-ice and De-ice Systems chapter of this manual for inspection procedures.

K. Anti-ice System

Refer to the Anti-ice and De-ice Systems chapter of this manual for inspection procedures.

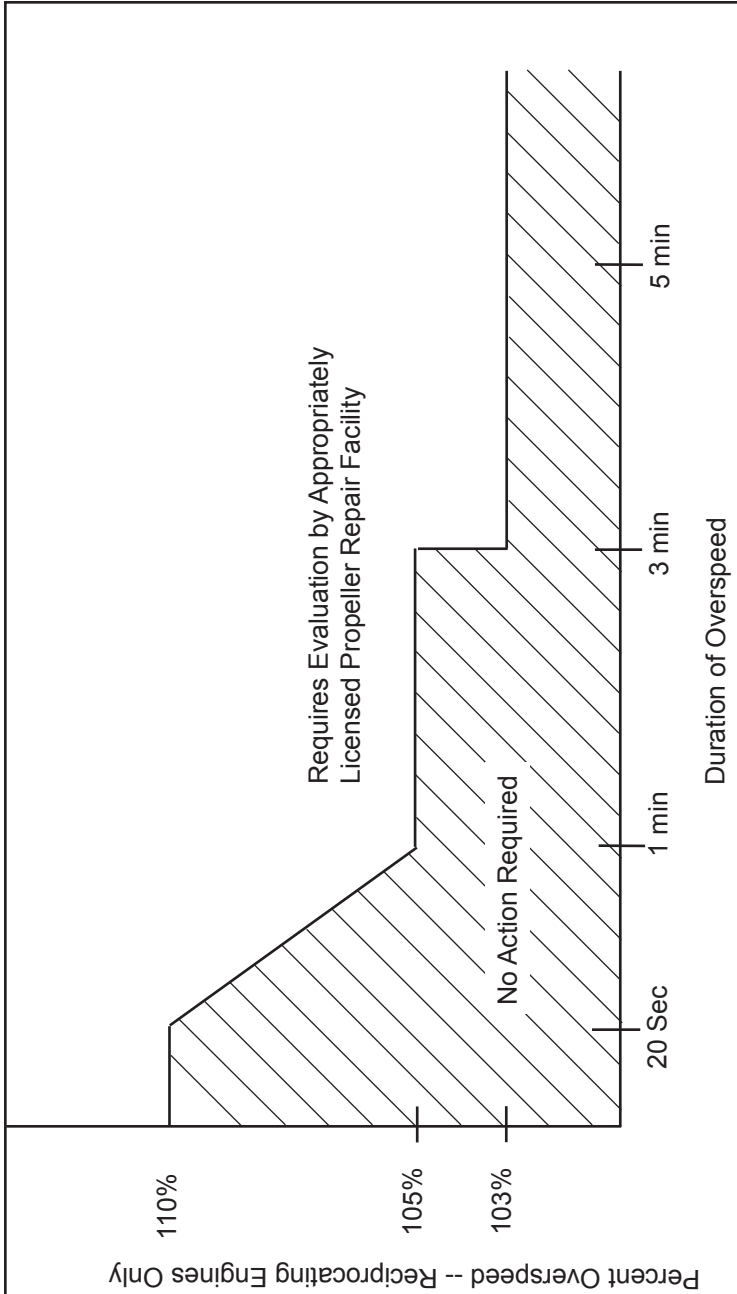

Reciprocating Engine Overspeed Limits
Figure 5-3

5. Special Inspections**A. Overspeed/Overtorque**

An overspeed occurs when the propeller RPM exceeds the maximum RPM stated in the applicable Aircraft Type Certificate Data Sheet. An overtorque condition occurs when the engine load exceeds the limits established by the engine, propeller, or airframe manufacturer. The duration of time at overspeed/overtorque for a single event determines the corrective action that must be taken to make sure no damage to the propeller has occurred.

The criteria for determining the required action after an overspeed are based on many factors. The additional centrifugal forces that occur during overspeed are not the only concern. Some applications have sharp increases in vibratory stresses at RPMs above the maximum rated for the airframe/engine/propeller combination.

- (1) When a propeller installed on a reciprocating engine has an overspeed event, refer to the Reciprocating Engine Overspeed Limits (Figure 5-3) to determine the appropriate corrective action.
- (2) Make an entry in this logbook about the overspeed event.

B. Lightning Strike

CAUTION: ALSO CONSULT ENGINE AND AIRFRAME MANUFACTURER'S MANUALS. THERE MAY BE ADDITIONAL REQUIREMENTS SUCH AS DE-ICE AND ENGINE SYSTEM CHECKS TO PERFORM AFTER A PROPELLER LIGHTNING STRIKE.

(1) General

- (a) In the event of a propeller lightning strike, an inspection is required before further flight. It may be permissible for a propeller to be operated for an additional ten (10) hours if the propeller is not severely damaged and meets the requirements in paragraph 5.B.(2).
- (b) Regardless of the outcome of the initial inspection, the propeller must be removed from the aircraft, disassembled, evaluated, and/or repaired by an appropriately licensed propeller repair facility.

(2) Procedure for Temporary Operation

If temporary additional operation is desired before propeller removal and disassembly:

- (a) Remove the spinner dome and perform a visual inspection of the propeller, spinner, and de-ice system for evidence of significant damage that would require repair before flight (such as broken de-ice wires or arcing damage to the propeller hub).

CAUTION: IF THE PROPELLER EXPERIENCES A LIGHTNING STRIKE, THE COMPOSITE BLADES MUST BE WITHIN AIRWORTHY LIMITS FOR ANY ADDITIONAL FLIGHT.

- (b) Perform a visual and coin tap inspection of the composite blades that have indications of arcing. If the only evident damage is minor arcing and all other criteria do not exceed airworthy damage limits stated in the Maintenance Practices chapter, then operation for ten (10) hours is acceptable before disassembly and inspection.

- (c) Perform a functional check of the propeller de-ice system (if installed) in accordance with aircraft maintenance manual procedures.
- (d) Regardless of the degree of damage, make an entry in this logbook about the lightning strike.
- (e) The propeller must be removed from the aircraft, disassembled, evaluated, and/or repaired by an authorized propeller repair station for further flight beyond the temporary operation limits granted above.

C. Foreign Object Strike/Ground Strike**(1) General**

- (a) A foreign object strike can include a broad spectrum of damage, from a minor stone nick to severe ground impact damage. A conservative approach in evaluating the damage is required because there may be hidden damage that is not readily apparent during an on-wing, visual inspection.
- (b) A foreign object strike is defined as:
 - 1 Any incident, whether or not the engine is operating, that requires repair to the propeller other than minor dressing of the blades. Examples of foreign object strike include situations where an aircraft is stationary and the landing gear collapses, causing one or more blades to be significantly damaged, or where a hangar door (or other object) strikes the propeller blade. These cases should be handled as foreign object strikes because of potentially severe side loading on the propeller hub, blades and retention bearings.
 - 2 Any incident during engine operation in which the propeller impacts a solid object that causes a drop in revolutions per minute (RPM) and also requires structural repair of the propeller (incidents requiring only paint touch-up are not included). This is not restricted to propeller strikes against the ground.
 - 3 A sudden RPM drop while impacting water, tall grass, or similar yielding medium, where propeller blade damage is not normally incurred.

(2) Procedure

- (a) In the event of a foreign object strike, an inspection is required before further flight. If the inspection reveals one or more of the following indications, the propeller must be removed from the aircraft, disassembled and repaired or overhauled in accordance with the applicable propeller and blade maintenance manuals.
 - 1 A loose blade in the hub.
 - 2 Any noticeable or **suspected** damage to the pitch change mechanism.
 - 3 A blade out of track or angle.
 - 4 Any diameter reduction.
 - 5 A bent, cracked, or failed engine shaft
 - 6 A blade rotated in the clamp.
 - 7 Vibration during operation that was not present before the event.
- (b) Unairworthy damage on composite blade surfaces or the leading and trailing edges must be repaired before flight. Refer to the Composite Blades section in the Maintenance Procedures chapter of this manual.
- (c) For engine mounted accessories - for example, governors, pumps, and propeller control units manufactured by Hartzell - if the foreign object strike resulted in a sudden stop of the engine, the unit must be disassembled and inspected in accordance with the applicable maintenance manual.
- (d) Regardless of the degree of damage, make an entry in this logbook about the foreign object strike incident and any corrective action(s) taken.

D. Fire Damage or Heat Damage

WARNING: EXPOSING COMPOSITE BLADES AND ALUMINUM HUBS TO HIGH TEMPERATURES MAY LEAD TO FAILURE THAT CAN CAUSE PERSONAL INJURY AND DEATH. ALUMINUM HUBS ARE MANUFACTURED FROM HEAT TREATED FORGINGS THAT ARE NOT TO BE ANNEALED AND RE-HEAT TREATED. EXPOSURE TO HIGH TEMPERATURES CAN ALSO DESTROY THE FATIGUE LIFE BENEFITS OBTAINED FROM SHOT PEENING. COMPOSITE BLADES ARE SUBJECT TO DELAMINATIONS BECAUSE OF HIGH TEMPERATURES.

- (1) On rare occasions propellers may be exposed to fire or heat damage, such as an engine or hangar fire. In the event of such an incident, an inspection by an authorized propeller repair station is required before further flight.

6. Long Term Storage

- A. Parts shipped from the Hartzell factory are not shipped or packaged in a container that is designed for long term storage.
- B. Long term storage procedures may be obtained by contacting a Hartzell distributor, or the Hartzell factory via the Product Support number listed in the Introduction chapter of this manual. Storage information is also detailed in Hartzell Standard Practices Manual 202A (61-01-02).
- C. Information regarding the return of a propeller assembly to service after long term storage may be obtained by contacting a Hartzell distributor, or the Hartzell factory via the Product Support number listed in the Introduction chapter of this manual. This information is also detailed in Hartzell Standard Practices Manual 202A (61-01-02).

(This page is intentionally blank.)

MAINTENANCE PRACTICES - CONTENTS

1. Cleaning	6-5
A. General Cleaning	6-5
B. Spinner Cleaning and Polishing	6-5
2. Lubrication	6-7
A. Lubrication Intervals	6-7
B. Lubrication Procedure	6-9
C. Approved Lubricants	6-12
3. Air Charge (-2 Propellers)	6-13
A. Charging the Propeller	6-13
4. Composite Blades	6-14
A. General Description	6-14
B. Component Life and Service	6-18
C. Personnel Requirements	6-20
D. Determination of Repair	6-21
E. Blade Inspection Requirements	6-24
F. Coin-Tap Test	6-26
G. Airworthy Damage	6-27
H. Unairworthy Damage	6-33
I. On Wing Blade Shank Inspection	6-35
J. Lightning Strike Damage	6-37
K. Minor Repair	6-39
5. Painting of Composite Blades	6-40
A. General	6-40
B. Procedure	6-41
C. Optional Removal of Leading Edge Paint for N7605(B,K) and N7605C() Blades	6-42.1
6. Dynamic Balance	6-44
A. Overview	6-44
B. Inspection Procedures Before Balancing	6-45
C. Modifying Spinner Bulkhead to Accommodate Dynamic Balance Weights	6-46
D. Placement of Balance Weights for Dynamic Balance	6-47
7. Propeller Low Pitch Setting	6-49
A. Low Pitch Stop - All Propeller Models	6-49
B. Max. RPM (Static) Low Pitch Stop Adjustment	6-51

MAINTENANCE PRACTICES - CONTENTS, CONTINUED

8. Propeller High Pitch Settings	6-53
A. High Pitch (Min. RPM) Stop	6-53
9. Start Lock Settings	6-53
A. Start Lock Pitch Stop	6-53
10. Accumulator Part Number Change	6-54
A. General	6-54
B. Material Information	6-55
C. Accomplishment Instructions	6-55
11. Propeller Ice Protection Systems	6-56
A. Electric De-ice System	6-56
B. Anti-ice System	6-56
12. Installation of Erosion Tape CM158	6-57
A. General	6-57
B. Materials Required	6-58
C. Installation Procedure	6-59

LIST OF FIGURES

Grease Fitting and Air Charge		
Valve Location	Figure 6-1	6-6
Lubrication Fitting	Figure 6-2	6-8
Lubrication Label	Figure 6-3	6-9
Section of Typical Composite Blade		
(C)7690(E,J), B7421, or 7890K.....	Figure 6-4	6-14
Basic Components of a Composite Blade		
(C)7690(E,J), B7421, or 7890K.....	Figure 6-5	6-15
Section of Typical N-shank Composite Blade	Figure 6-6	6-16
Basic Components of an N-shank		
Composite Blade	Figure 6-7	6-17
Determination of Repair Flow Chart	Figure 6-8	6-21
Coin-Tap Test to Check for Debonds and Delaminations.....	Figure 6-9	6-26
Interpretation of Erosion Shield Damage.....	Figure 6-10	6-28
Missing Portion of the Erosion Shield (Trailing Edge).....	Figure 6-11	6-29
Acceptable Erosion Shield Damage and Unacceptable Crack Locations.....	Figure 6-12	6-31
Debonds Exceeding the Allowable Limits.....	Figure 6-13	6-31
Blade Regions - All Except N-shank Blades..	Figure 6-13.1	6-32
Blade Regions - N-shank Blades Only	Figure 6-13.2	6-32.4
N-shank Kevlar®/Carbon Hybrid Blade Limits..	Figure 6-13.3	6-32.7
Crushed and Cracked Trailing Edge.....	Figure 6-14	6-33
Inspection Areas for Counterweighted and Non-counterweighted Blades	Figure 6-15	6-34
Evidence of Lightning Strike Damage to Composite Blade	Figure 6-16	6-36
Removal of the Leading Edge Paint	Figure 6-16.1	6-42.1
Low Pitch Stop Adjustment (-1, -4).....	Figure 6-17	6-50
Low Pitch Stop Adjustment (-2).....	Figure 6-18	6-50
Accumulator Part Number Change.....	Figure 6-19	6-54

LIST OF TABLES

Air Charge Pressure	Table 6-1	6-13
Approved Touch-up Paints	Table 6-2	6-40
■ Erosion Tape.....	Table 6-3	6-58

1. Cleaning

CAUTION: DO NOT USE PRESSURE WASHING EQUIPMENT TO CLEAN THE PROPELLER OR CONTROL COMPONENTS. PRESSURE WASHING CAN FORCE WATER AND/OR CLEANING FLUIDS PAST SEALS AND LEAD TO INTERNAL CORROSION OF PROPELLER COMPONENTS.

A. General Cleaning

CAUTION 1: WHEN CLEANING THE PROPELLER, DO NOT PERMIT SOAP OR SOLVENT SOLUTIONS TO RUN OR SPLASH INTO THE HUB AREA.

CAUTION 2: DO NOT CLEAN THE PROPELLER WITH CAUSTIC OR ACIDIC SOAP SOLUTIONS. IRREPARABLE CORROSION OF PROPELLER COMPONENTS MAY OCCUR.

CAUTION 3: DO NOT USE ANY SOLVENT DURING CLEANING THAT COULD SOFTEN OR DESTROY THE BOND BETWEEN CHEMICALLY ATTACHED PARTS.

(1) To remove grease or oil from propeller surfaces, apply Stoddard Solvent or equivalent to a clean cloth and wipe the part clean.

(2) Using a noncorrosive soap solution, wash the propeller.

(3) Thoroughly rinse with water.

(4) Permit to dry.

B. Spinner Cleaning and Polishing

(1) Clean the spinner using the General Cleaning procedures, above.

(2) Polish the dome, if necessary, an automotive-type aluminum polish.

AFS6156

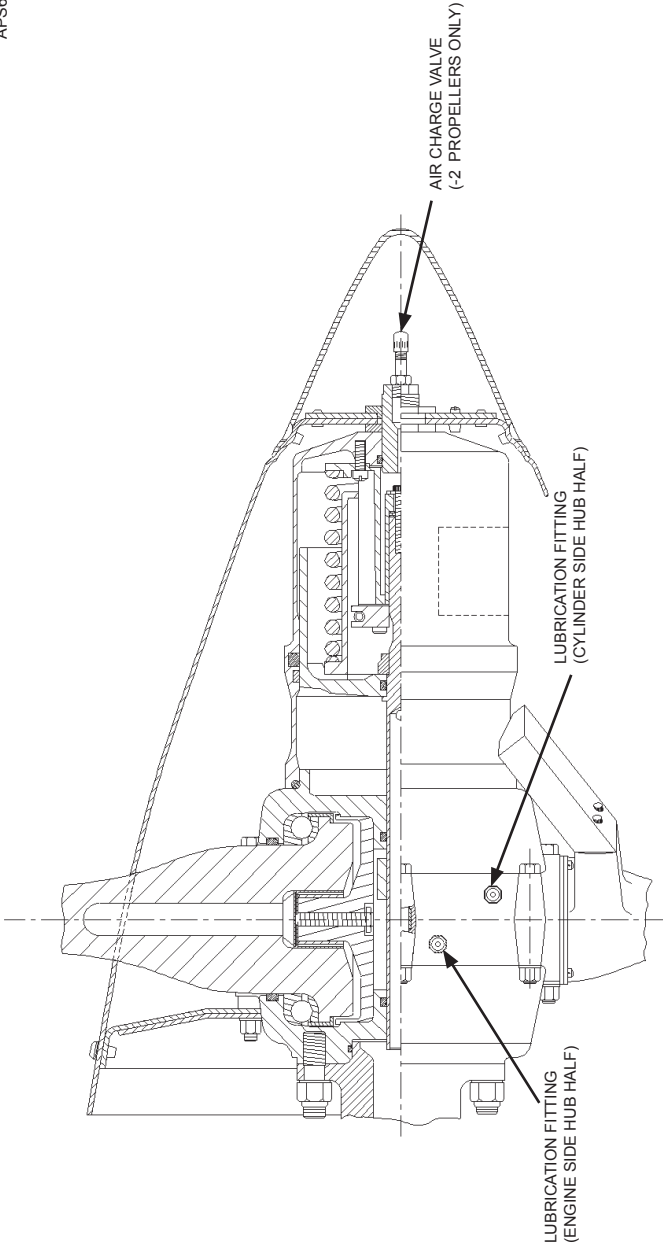

**Grease Fitting and Air Charge Valve Location
Figure 6-1**

2. Lubrication**A. Lubrication Intervals**

- (1) The propeller must be lubricated at intervals not to exceed 100 hours or at 12 calendar months, whichever occurs first.
 - (a) If annual operation is significantly less than 100 hours, calendar lubrication intervals should be reduced to six months.
 - (b) If the aircraft is operated or stored under adverse atmospheric conditions, e.g., high humidity, salt air, calendar lubrication intervals should be reduced to six months.
- (2) Owners of high use aircraft may wish to extend their lubrication interval. Lubrication interval may be gradually extended after evaluation of previous propeller overhauls with regard to bearing wear and internal corrosion.
- (3) Hartzell recommends that new or newly overhauled propellers be lubricated after the first one or two hours of operation because centrifugal loads will pack and redistribute grease, which may result in a propeller imbalance. Redistribution of grease may also result in voids in the blade bearing area where moisture can collect.
 - (a) Purchasers of new aircraft should check the propeller logbook to verify whether the propeller was lubricated by the manufacturer during flight testing. If it was not lubricated, the propeller should be serviced at the earliest convenience.

TI-00102

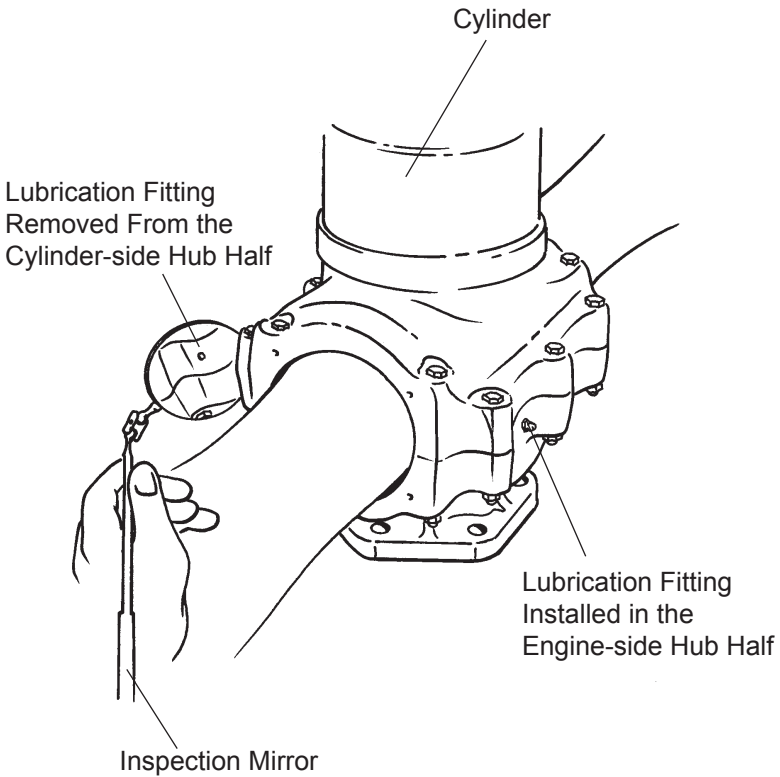

NOTE: A 2-blade propeller is shown for illustration purposes only.

Lubrication Fitting
Figure 6-2

B. Lubrication Procedure

WARNING 1: FOLLOW LUBRICATION PROCEDURES CORRECTLY TO MAINTAIN ACCURATE BALANCE OF THE PROPELLER ASSEMBLY

WARNING 2: .PITCH CONTROL DIFFICULTY COULD RESULT IF THE PROPELLER IS NOT CORRECTLY LUBRICATED.

- (1) Remove the propeller spinner.
- (2) Refer to Figure 6-1 and Figure 6-2. Each blade socket has two lubrication fittings. Remove the lubrication fitting caps the lubrication fittings. Remove the lubrication fittings from either the cylinder-side or the engine side of the hub assembly.
 - (a) It is preferable to apply grease to the fitting located nearest the leading edge of the blade on a tractor installation, or nearest the trailing edge on a pusher installation. Lubricating at this location reduces the possibility of grease bypassing the bearing area and entering the hub cavity.
 - (b) Some propellers use an internal blade seal that prevents grease from entering the hub cavity. It is important to remove the opposite lubrication fitting.
- (3) Using a piece of safety wire, loosen any blockage or hardened grease at the threaded holes where the lubrication fitting was removed.

A-3594

PROPELLER S/N _____
LUBRICATED WITH _____
THIS GREASE MUST BE USED ON
ALL SUBSEQUENT LUBRICATIONS.
LABEL A-3594

Lubrication Label
Figure 6-3

WARNING: WHEN MIXING AEROSHELL GREASES 5 AND 6, AEROSHELL GREASE 5 MUST BE INDICATED ON THE LABEL (HARTZELL P/N A-3594) AND THE AIRCRAFT MUST BE PLACARDED TO INDICATE THAT FLIGHT IS PROHIBITED IF THE OUTSIDE AIR TEMPERATURE IS LESS THAN -40°F (-40°C).

CAUTION: USE HARTZELL PROPELLER APPROVED GREASE ONLY. EXCEPT IN THE CASE OF AEROSHELL GREASES 5 AND 6, DO NOT MIX DIFFERENT SPECIFICATIONS AND/OR BRANDS OF GREASE.

- (4) Aeroshell greases 5 and 6 both have a mineral oil base and have the same thickening agent; therefore, mixing of these two greases is permitted in Hartzell propellers.
- (5) A label (Hartzell P/N A-3494) is normally applied to the propeller to indicate the type of grease previously used. Refer to Figure 6-3.
 - (a) This grease type should be used during re-lubrication unless the propeller has been disassembled and the old grease removed.
 - (b) Purging of old grease through lubrication fittings is only about 30 percent effective.
 - (c) To completely replace one grease with another, the propeller must be disassembled in accordance with the applicable overhaul manual.

CAUTION 1: OVER-LUBRICATING AN ALUMINUM HUB PROPELLER MAY CAUSE THE GREASE TO ENTER THE HUB CAVITY, LEADING TO EXCESSIVE VIBRATION AND/OR SLUGGISH OPERATION. THE PROPELLER MUST THEN BE DISASSEMBLED TO REMOVE THIS GREASE.

CAUTION 2: IF A PNEUMATIC GREASE GUN IS USED, EXTRA CARE MUST BE TAKEN TO AVOID EXCESSIVE PRESSURE BUILDUP.

CAUTION 3: GREASE MUST BE APPLIED TO ALL BLADES OF A PROPELLER ASSEMBLY AT THE TIME OF LUBRICATION.

- (6) Pump 1 fl. oz. (30 ml) grease into the fitting located nearest the leading edge of the blade on a tractor installation, or nearest the trailing edge on a pusher installation, or until grease emerges from the hole where the fitting was removed - whichever occurs first.

NOTE: 1 fl. oz. (30 ml) is approximately 6 pumps with a hand-operated grease gun.

- (7) Reinstall the removed lubrication fittings. Tighten the fittings until snug.
- (a) Make sure that the ball of each lubrication fitting is properly seated.
- (8) Reinstall a lubrication fitting cap on each lubrication fitting.

C. Approved Lubricants

The following lubricants are approved for use in Hartzell compact propellers:

- Aeroshell 6 - Recommended "all purpose" grease. Used in most new production propellers since 1989. Higher leakage/oil separation than Aeroshell 5 at higher temperatures (approximately 100°F [38°C]).
- Aeroshell 5 - Good high temperature qualities, very little oil separation or leakage. Cannot be used in temperatures colder than -40°F (-40°C). Aircraft serviced with this grease must be placarded to indicate that flight is prohibited if the outside air temperature is less than -40°F (-40°C).
- Aeroshell 7 - Good low temperature grease, but high leakage/oil separation at higher temperatures. This grease has been associated with sporadic problems involving seal swelling.
- Aeroshell 22 - Qualities similar to Aeroshell 7.
- Royco 22CF - Not widely used. Qualities similar to Aeroshell 22.

3. Air Charge (-2 Propellers)**A. Charging the Propeller**

WARNING: DO NOT CHARGE THE CYLINDER OR MEASURE THE AIR CHARGE ON A PROPELLER THAT IS IN FEATHER POSITION.

- (1) Examine the propeller to make sure that it is positioned on the start locks
- (2) Using proper control, charge the cylinder with dry air or nitrogen.
 - (a) The air charge valve is located on the cylinder as indicated in Figure 6-1.
 - (b) Nitrogen is the preferred charging medium.
 - (c) The proper charge pressure is identified in Table 6-1 in this chapter.

°F	°C	P.S.I.	Bar
100 to 70	38 to 21	41	2.9
40 to 70	4 to 21	38	2.6
0 to 40	-18 to 4	36	2.5
-30 to 0	-34 to -18	33	2.3

**Air Charge Pressure
Table 6-1**

4. Composite Blades

A. General Description

(1) (C)7690(E,J), B7421, 7890K Blades

- (a) The Hartzell composite blade is composed of a metal blade shank (plug) that has a low-density foam core molded into it. The low-density foam core supports built-up layers of composite laminates (Figure 6-4).
- (b) An erosion shield of electroformed nickel is incorporated into the fabrication to protect the blade leading edge from impact damage. The erosion shield is adhesively bonded to the blade.
- (c) Filament windings of composite material (Figure 6-5) provide blade retention for the blade material to the internal metal plug. The composite laminates that are an integral component of the blade, also provide a retention load path directly under the bearing in aluminum hubs for blade retention.

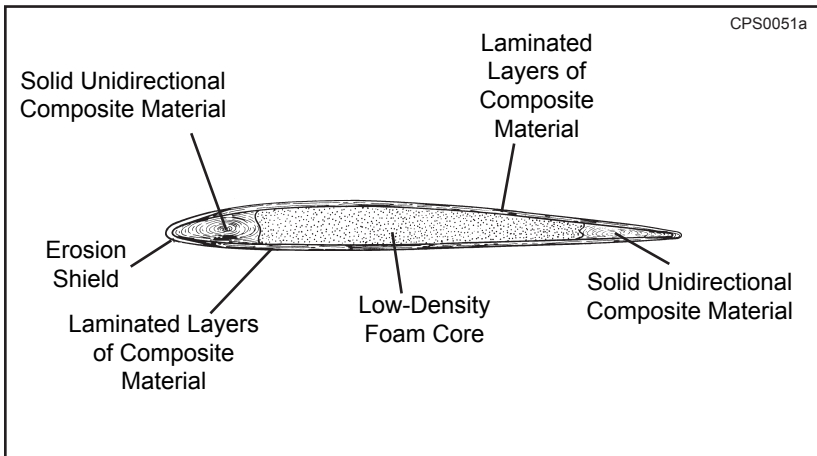

Section of Typical Composite Blade (C)7690(E,J), B7421, or 7890K
Figure 6-4

- (d) Some designs use a filament winding on the inboard end of the erosion shield to aid the retention of the erosion shield. This winding is sometimes referred to as an erosion shield winding and should not be confused with the blade retention winding used to secure the blade material to the internal metal plug.
- (e) The composite blade is balanced in the horizontal plane during production by the addition of lead wool to a centrally located balance tube in the metal blade shank (which may protrude into the blade's foam core).
- (f) A finish covering of polyurethane paint protects the entire blade from erosion, as well as ultraviolet damage. Aircraft that require ice protection use an external boot.

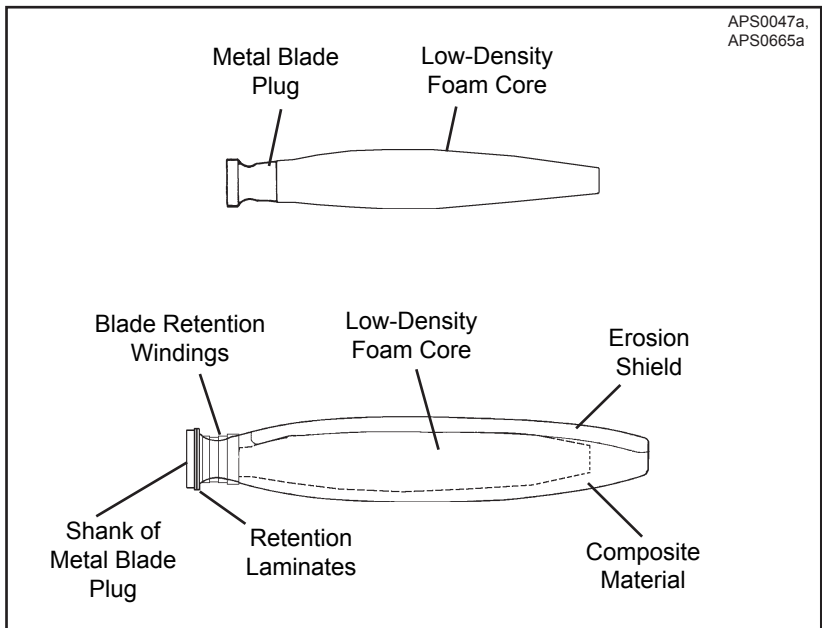

Basic Components of a Composite Blade (C)7690(E,J), B7421, or 7890K
Figure 6-5

(2) N-shank Composite Blades

- (a) The Hartzell N-shank blade is a monocoque construction consisting of composite material over a foam core.
- (b) The composite material is round at the inboard station sections, transitioning to an airfoil shape outboard on the blade. A typical airfoil section is shown in Figure 6-6. The bulk of the composite material is truncated toward the trailing edge with foam material forming the remainder of the trailing edge. The entire structure is contained in a shell constructed of composite material.
 - 1 Some blades have a conductive metal foil, included for lightning protection, as the most outer layer.

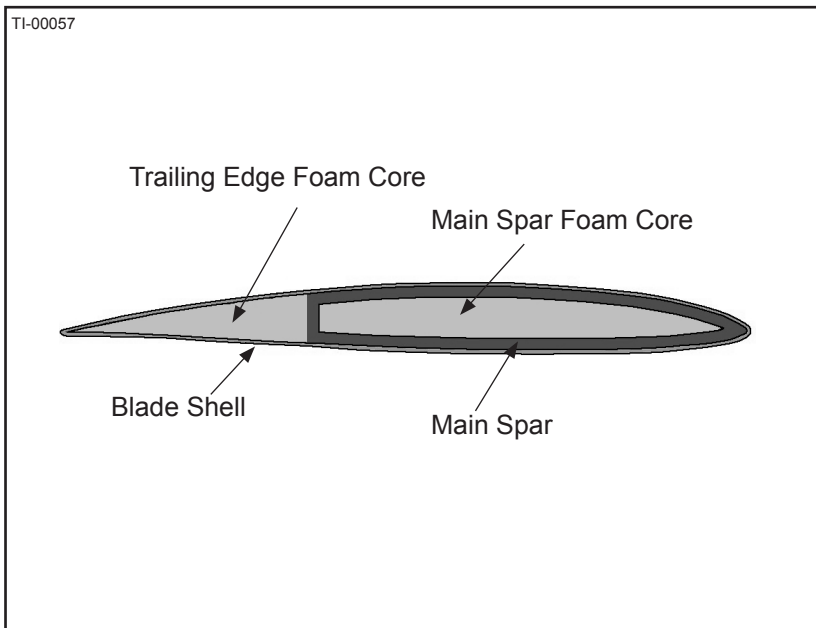

**Section of Typical N-shank Composite Blade
Figure 6-6**

- (c) An erosion shield of electroformed nickel is incorporated in the fabrication to protect the leading edge of the blade from impact and erosion damage.
- (d) The shank is constructed of stainless steel.
 - 1 The outer shank contains a integral knob similar to a Hartzell "Y" shank and uses blade shank tape, also similar to a Hartzell "Y" shank. Refer to Figure 6-7.
- (e) The composite blade is balanced in the horizontal plane during production by the addition of lead wool to a centrally located balance tube in the metal blade shank, which may protrude into the foam core of the blade.
- (f) A finish covering of polyurethane paint protects the entire blade from erosion and ultraviolet damage.
- (g) Aircraft that require ice protection use an external boot.

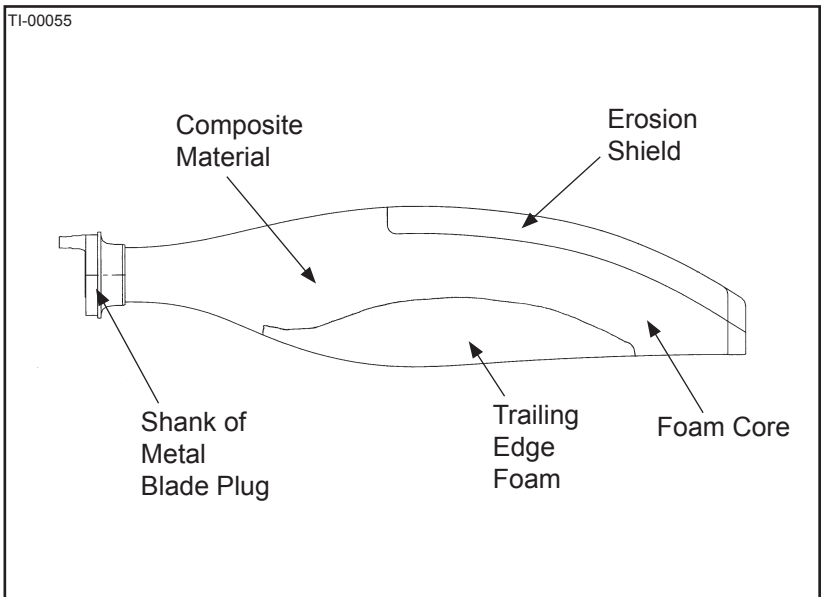

**Basic Components of an N-shank Composite Blade
Figure 6-7**

B. Component Life and Service**(1) Overhaul or Major Periodic Inspection (MPI)**

- (a) Overhaul, or MPI, is the periodic disassembly, inspection, repair, refinish and reassembly of the composite blade assembly.

NOTE: The term “overhaul” is used throughout the text of this manual.

- (b) At such specified periods, the propeller hub assembly and the blade assemblies are completely disassembled and inspected for cracks, wear, corrosion and other unusual or abnormal conditions. As specified, some blades are refinished, and other blades are replaced. The blades can then be reassembled and balanced.

- (c) Overhaul procedures must be performed in accordance with the latest revision of Hartzell Composite Blade Manual 135F (61-13-35) and other applicable publications.

- (d) Overhaul must be performed only by a Hartzell Propeller Inc. approved propeller repair facility.

(2) Damage**(a) Airworthy Damage**

CAUTION: ALTHOUGH A BLADE MAY CONTINUE IN SERVICE WITH AIRWORTHY DAMAGE, THIS TYPE OF DAMAGE SHOULD BE REPAIRED AT THE EARLIEST PRACTICAL TIME.

- 1 Airworthy damage is a specific condition to a blade identified in this chapter that does not affect the safety or flight characteristics of the propeller blade and conforms to its type design by meeting the condition inspection criteria limitations found in this chapter.

- a** The maximum limits of airworthy damage are specified in the Airworthy Damage section of this chapter.

b This chapter provides inspection criteria and direction to evaluate damage to determine continued airworthiness.

2 Although a blade may continue in service with airworthy damage, this type of damage should be repaired at the earliest practical time to prevent the damage from progressing to a condition that could require more extensive repair to the blade.

(b) Unairworthy Damage

CAUTION: IN MOST CASES, UNAIRWORTHY DAMAGE MUST BE REPAIRED BEFORE THE NEXT FLIGHT.

1 Unairworthy damage is damage that exceeds the airworthy damage limits as specified in this chapter.

a Unairworthy damage can affect the safety or flight characteristics of the propeller blade and does not conform to its type design.

b This condition deems the blade unairworthy, requiring appropriate corrective action to repair or remove it from service, as applicable.

(3) Repair

(a) Minor Repair

Minor repair is correction of damage that may be safely performed in the field (preferably by appropriately trained personnel who have completed Hartzell composite blade training).

(b) Major Repair

1 Major repair is correction of damage that cannot be performed by elementary operations.

2 Major repair must be accepted by an individual certified by the appropriate Aviation Authority, preferably one that holds a Factory Training Certificate from Hartzell Propeller, Inc.

3 All major repairs must be completed in an FAA approved repair station.

(4) Blade Life

Blade life is expressed in terms of total hours of service (TT, or Total Time), time between overhauls (TBO) and in terms of service since overhaul (TSO, or Time Since Overhaul). All references are necessary in defining the life of the propeller.

C. Personnel Requirements

(1) Compliance to the applicable regulatory requirements established by the Federal Aviation Administration (FAA) or appropriate Aviation Authority is mandatory for anyone performing or accepting responsibility for any inspection and/or repair and/or overhaul of any Hartzell Propeller Inc. product.

(2) Any person signing for or performing inspections, repairs and/or overhauls to Hartzell composite parts should be familiar with the objectives and procedures associated with the inspection, repair and/or overhaul of composite parts.

NOTE: It is strongly recommended that the individuals taking the responsibilities for or performing the tasks of inspecting, repairing and/or overhauling of composite parts attend Hartzell Propeller Inc. Factory Training Courses.

All persons who receive factory training are supplied with a "Certificate of Factory Training" after completion of training. A copy of all certificates are kept on file at Hartzell Propeller Inc.

To keep informed of the new techniques for the inspection, repair and overhaul of composite parts, it is strongly recommended that training be received at least once every three years, with intermediate classes occurring as the need arises. For class dates, arrangements, and information, contact the Hartzell Product Support Department or visit the Hartzell Propeller Inc. website at www.hartzellprop.com.

D. Determination of Repair

(1) This section is arranged such that damage and repair are treated separately. This gives the operators and repair facilities greater clarification and freedom in dealing with composite blade damage.

(a) This section defines airworthy and unairworthy damage, and also lists the allowables for each.

(b) The type of repair is not dictated by the type of damage received. For example, a blade with airworthy damage may require a major repair.

(2) Determination of Type of Damage

Upon inspection of a composite propeller blade, an operator should first determine whether the type of damage is airworthy or unairworthy. (Limits are in this chapter.) Figure 6-8 illustrates the determination of repair.

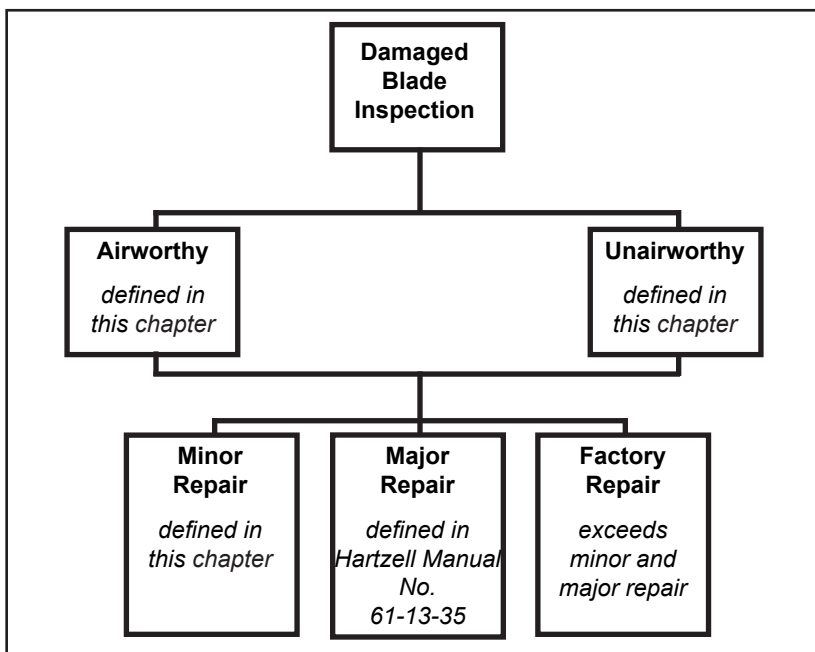
**Determination of Repair Flow Chart****Figure 6-8**

- (a) If the damage is determined to be airworthy, the aircraft may continue in service; however, the operator should make arrangements to have repairs performed as soon as practical.
- 1 Because of the infinite types of damage possible, not all types of damage that can be considered airworthy are covered in this manual. If there is any doubt as to airworthiness of the blade, contact Hartzell Propeller Inc.
- (b) In most cases, if the damage is determined to be unairworthy, the propeller blade cannot be used until a repair is performed.

(3) Determination of Type of Repair

The operator should determine if the repair falls into the category of minor or major. Limits for each repair are called out in the repair procedure.

(a) If the repair is minor, it may be made on location. An individual approved by the appropriate aviation authority must sign off the acceptance of the return to service (refer to the Personnel Requirements section of this chapter).

(b) If the repair is major, the operator must make arrangements to have the damage repaired at an appropriately licensed repair facility. The repair must be signed off by an individual that possesses approval by the appropriate Aviation authority (refer to the Personnel Requirements section of this chapter).

(4) Because of the infinite types of damage possible, not all types of damage that can be considered airworthy are covered in this manual. If there is any doubt about the airworthiness of the blade, contact Hartzell Propeller Inc.

E. Blade Inspection Requirements

CAUTION: MAINTAINING A GOOD LOGBOOK RECORD IS PARTICULARLY IMPORTANT FOR COMPOSITE PROPELLER BLADES. DAMAGE AND/OR REPAIRS MAY SUFFER FURTHER DEGRADATION AFTER CONTINUED USE. SUCH DEGRADATION MAY BE EASILY OVERLOOKED. IT IS IMPORTANT FOR INSPECTORS TO HAVE ACCESS TO ACCURATE HISTORICAL DATA WHEN PERFORMING SUBSEQUENT INSPECTIONS.

(1) Required Record-Keeping

- (a) Composite blade damage and a description of the repair must be recorded in the composite blade logbook.

(2) Preflight Inspection

- (a) Follow propeller preflight inspection procedures as specified in the aircraft maintenance manual, or an air carrier's operational specifications, or this manual. In addition, perform the following inspections:
- 1** Visually inspect each entire blade for nicks, gouges, loose material, erosion, cracks and debonds.
 - 2** Visually inspect blades for lightning strike. Refer to "Lightning Strike Damage" in this chapter for a description of damage.
- (b) Defects or damage discovered during preflight inspection must be evaluated in accordance with allowables outlined in this chapter to determine if repairs are required before further flight.

(3) Maintenance Inspections

(a) Inspection procedures must be performed in accordance with this manual.

- 1 Perform a thorough visual inspection.
- 2 Perform a coin-tap test to the exposed section of the blade not to exceed 1200 hours and the erosion shield surface not to exceed 600 hours. Coin-tapping (described this chapter) will indicate a delamination or debond by an apparent audible change.
- 3 Review blade log book records and carefully inspect areas of airworthy damage and previously repaired areas for growth. If damage is growing, estimate whether the flawed area will larger than the permitted airworthy damage limits before the next overhaul. If this is the case, make arrangements to repair at the earliest practical time to prevent further damage to the blade.
- 4 Defects or damage discovered during scheduled inspections must be evaluated in accordance with allowables outlined later in this chapter to determine if repairs are required before further flight. Although repair of "airworthy damage" is not essential before further flight, such damage should always be repaired as soon as possible, to avoid further degradation. Unairworthy damage must be repaired before further flight.
- 5 Make a record of the details of all damage and/ or repairs in the composite blade logbook.

F. Coin-Tap Test

(1) Composite blades are inspected for delaminations and debonds by tapping the blade or cuff (if applicable) with a "metal washer."

(2) Procedure

(a) Using a washer-shaped metal tapper, approximately 2.5 inches OD x 1.25 inches ID x 0.25 inch (63 mm OD x 31.7 mm ID x 6.3 mm) thick, and weighing no less than 3 ounces, tap the surface. If an audible change is apparent, sounding hollow or dead, a debond or delamination is likely. Refer to Figure 6-9.

1 Blades that incorporate a "cuff" have a different tone when coin-tapped in the cuff area. To avoid confusing the sounds, coin tap the cuff area and the transition area between the cuff and the blade separately from the blade area.

2 N-shank blades incorporate a separate foam trailing edge and have a different tone when coin-tapped in that area. To avoid confusing sounds, coin tap the foam trailing edge area and the transition area between the foam trailing edge and the blade separately from the blade area.

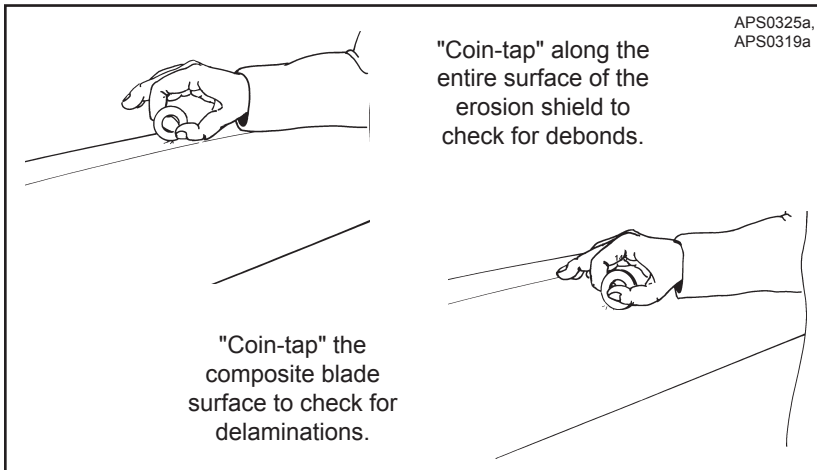

Coin-Tap Test to Check for Debonds and Delaminations
Figure 6-9

(3) Mapping

- (a) Mapping of the area to be coin-tapped is desirable to assure that the entire surface is adequately inspected. Coin-tap within an imaginary grid consisting of 2.00 sq. inches (1290 sq. mm) during scheduled aircraft inspections.
- (b) A more thorough coin-tapping of the erosion shield is desirable because of its size and shape. Tap in a smaller grid pattern up and down the length of the erosion shield. Slight deformations in the erosion shield may be noticed with careful visual and tactile (touch) inspection. Such deformations may be the result of a debond, and should be given a careful coin-tap inspection.
- (c) If a suspected delamination or debond is discovered, a localized, thorough coin-tap inspection is required to define the precise area of delamination or debond.

(4) Recording Damage

- (a) Outline the suspect area with a grease pencil to determine the approximate size of the damage.
- (b) Record the damage/repairs in the propeller log book.

G. Airworthy Damage

**CAUTION: AREAS OF AIRWORTHY DAMAGE
SHOULD BE MONITORED AND REPAIRED
AS SOON AS PRACTICAL.**

Airworthy damage does not exceed the following limits. This type of damage will not affect the safety or flight characteristics of the propeller.

(1) Airworthy Damage Limits**(a) Nickel Erosion Shield**

- 1** When calculating the area of damage and the proximity to other damage, the erosion shield should be viewed as a two dimensional shape, as if it were unfolded and laid flat where the face and camber sides of the blade could be viewed at the same time. Refer to Figure 6-10 for the interpretation of the view of the erosion shield.

- 2 The following limits apply to the entire erosion shield:
 - a The maximum permitted amount of deformed material because of impact damage or erosion not associated with a crack or missing material is less than 10 percent of the leading edge radius or no more than 0.080 inch (2.03 mm) deep.
 - b The maximum permitted total accumulated area of gouges through the erosion shield is 0.25 sq. in (161.2 sq. mm).
 - c The maximum permitted depth of damage to the blade surface beneath the erosion shield is 0.020 inch (0.50 mm). This is two layers of fibrous material. Exposed foam is not permitted.

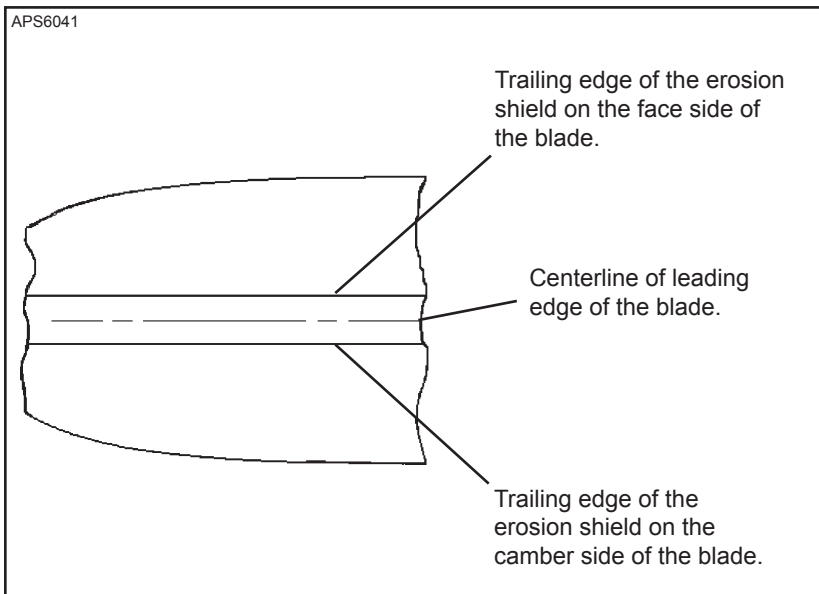

Interpretation of Erosion Shield Damage
Figure 6-10

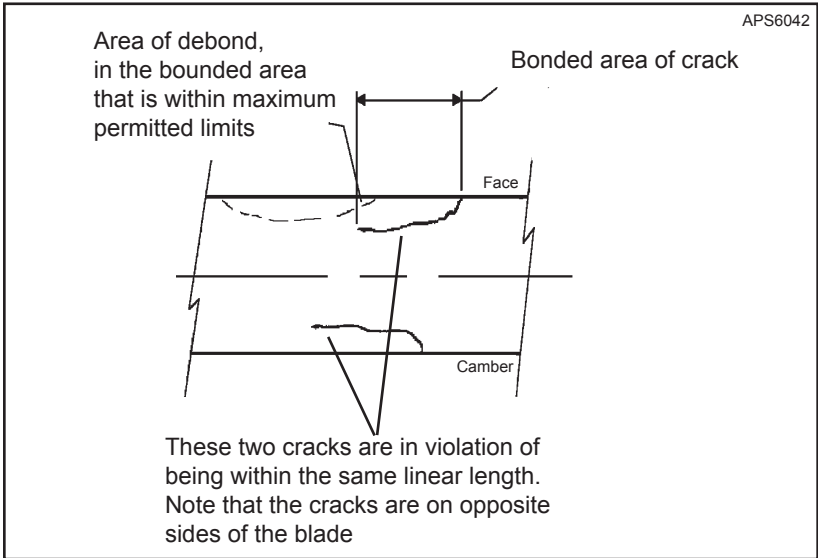

Acceptable Erosion Shield Damage and Unacceptable Crack Locations
Figure 6-12

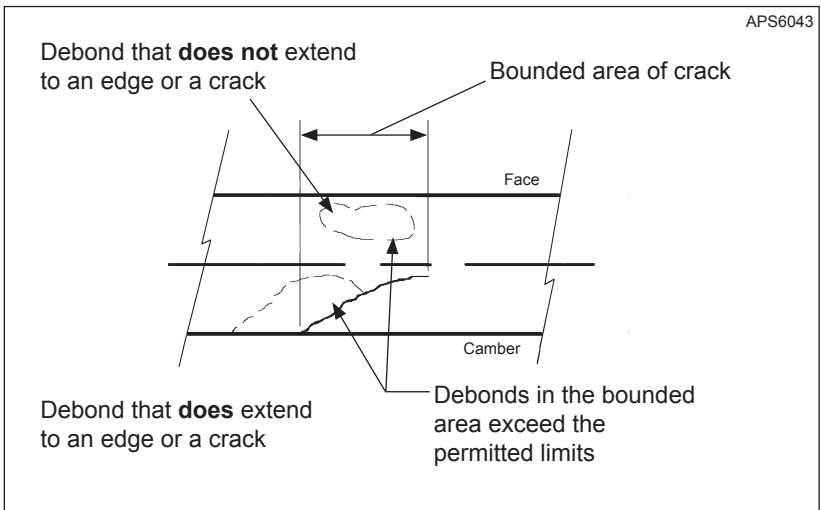

Debonds Exceeding the Allowable Limits
Figure 6-13

TI-135002

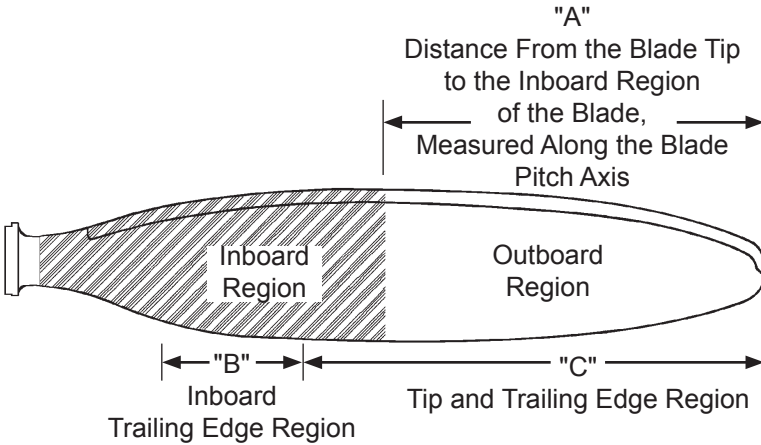

Blade Model	"A"	"B"	"C"
B7421(K)	18.00 inches (457.2 mm)	An Inboard Trailing Edge Region has not been defined for this blade	18.00 inches (457.2 mm)
()7690()	18.50 inches (469.9 mm)	An Inboard Trailing Edge Region has not been defined for this blade	18.50 inches (469.9 mm)
7890K	19.00 inches (482.6 mm)	An Inboard Trailing Edge Region has not been defined for this blade	19.00 inches (482.6 mm)

Blade Regions - All Except N-shank Blades
Figure 6-13.1

(b) Blade Damage - For All Except N-shank Blades
(Refer to Figure 6-13.1)

- 1 Gouge or Loss of Material - Outboard Region of the Blade
 - a The maximum permitted diameter or equivalent area (0.2 sq. in. or 129 sq. mm) of a gouge or loss of composite material is 0.500 inch (12.70 mm). The maximum permitted length of a gouge or loss of composite material is 2.5 inches (63 mm). The maximum permitted depth of a gouge or loss of material is 0.020 inch (.50 mm).
- 2 Gouge or Loss of Material - Inboard Region of the Blade
 - a A gouge or loss of composite material on the inboard region of the blade is unairworthy.
- 3 Delamination - Outboard Region of the Blade
 - a The maximum permitted area of delamination is 2.0 sq. inches (1290 sq. mm). A dark brown stain or black stain is not permitted.
- 4 Delamination - Inboard Region of the Blade
 - a A delamination on the inboard region of the blade is unairworthy.
- 5 Split Trailing Edge - Tip and Trailing Edge Region of the Blade
 - a The maximum permitted depth of a split area is 0.5 inch (12 mm). The maximum permitted length is 6.0 inches (152 mm). Damaged fibers or exposed foam are not permitted.
- 6 Split Trailing Edge - Inboard Region of the Blade
 - a A split trailing edge on the inboard region of the blade is unairworthy.

- 7 Crushed or Cracked Trailing Edge - Outboard and Tip Regions of the Blade
 - a The maximum permitted depth of a crushed or cracked area is 0.25 inch (6.3 mm). The maximum permitted length of a crushed or cracked area is 2.0 inches (50 mm).
- 8 Paint Erosion

The maximum permitted exposure of the composite material and/or the primer filler is 5.0 sq. inch (3225 sq. mm). This allowable does not refer to primer sealer.

 - a For maintenance scheduling purposes, propellers with blades that show more than 5.0 square inches (3225 sq. mm) of paint erosion may continue operation for an additional 250 hours or 1 (one) month, whichever occurs first.

(This page is intentionally blank.)

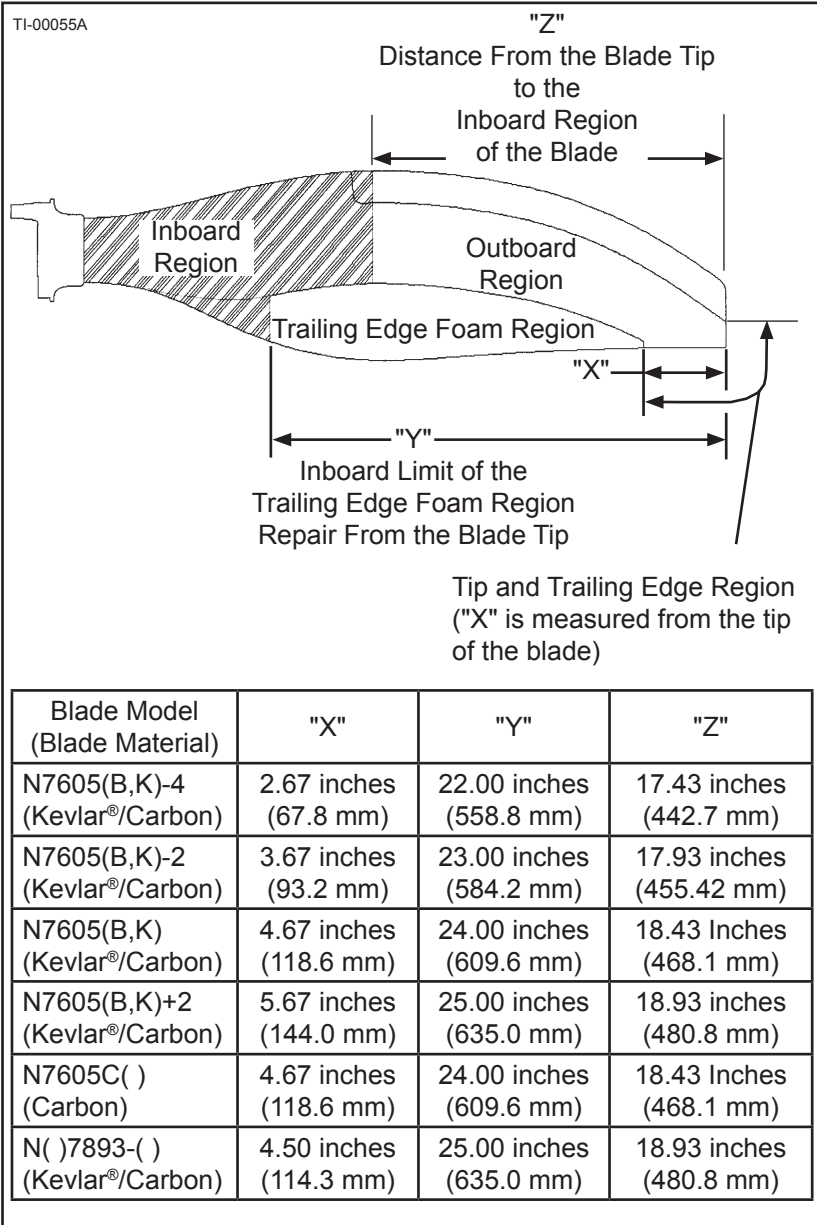

Blade Regions - N-shank Blades Only
Figure 6-13.2

- (c) Blade Damage - For N-shank Kevlar®/Carbon Hybrid Blades Only (Refer to Figure 6-13.2)
- 1 Gouge or Loss of Material - Outboard Region of the Blade
 - a For a gouge or loss of composite material that does not expose the carbon layer, the maximum permitted diameter or equivalent area (0.20 sq. inch or 129 sq. mm) of a gouge or loss of composite material is 0.500 inch (12.70 mm). The maximum permitted length of a gouge or loss of composite material is 2.5 inch (63 mm).
 - b For a gouge or loss of composite material that does expose the carbon layer, the maximum permitted length dimension is 0.500 inch (12.70 mm). The maximum permitted area of the exposed carbon layer is 0.14 sq. inch (90 sq. mm). A gouge or loss of composite material is not permitted to penetrate the outermost carbon layer.
 - 2 Gouge or Loss of Material - Trailing Edge Foam Region of the Blade
 - a The maximum permitted diameter or equivalent area of a gouge or loss of composite material is 0.500 inch (12.70 mm). The maximum permitted length of a gouge or loss of composite material is 2.5 inch (63 mm). The maximum permitted depth of a gouge or loss of composite material is 0.020 inch (0.50 mm). Exposed foam or a delamination is not permitted.
 - 3 Gouge or Loss of Material - Inboard Region of the Blade
 - a A gouge or loss of composite material on the inboard region of the blade is unairworthy.

- 4 Delamination - Outboard Region of the Blade
 - a The maximum permitted area of delamination on the outboard half of the blade is 1.0 sq. inch (645 sq. mm).
- 5 Delamination - Trailing Edge Foam Region of the Blade
 - a The maximum permitted area of delamination is 2.0 square inch (1290 sq. mm). A dark brown stain or a black stain is not permitted. The delamination must not be associated with a crack, gouge, or other damage to the composite material.
- 6 Delamination - Inboard Region of the Blade
 - a A delamination on the inboard region of the blade is unairworthy.
- 7 Split Trailing Edge - Tip and Trailing Edge Region of the Blade
 - a The maximum permitted depth of a split area is 0.5 inch (12 mm). The maximum permitted length is 6.0 inches (152 mm). Damaged fibers are not permitted.
- 8 Split Trailing Edge - Inboard Region of the Blade
 - a A split trailing edge on the inboard region of the blade is unairworthy.
- 9 Crushed or Cracked Trailing Edge - Trailing Edge Foam Region of the Blade
 - a The maximum permitted depth of a crushed or cracked area is 0.25 inch (6.3 mm). The maximum permitted length of a crushed or cracked area is 2.0 inches (50 mm).

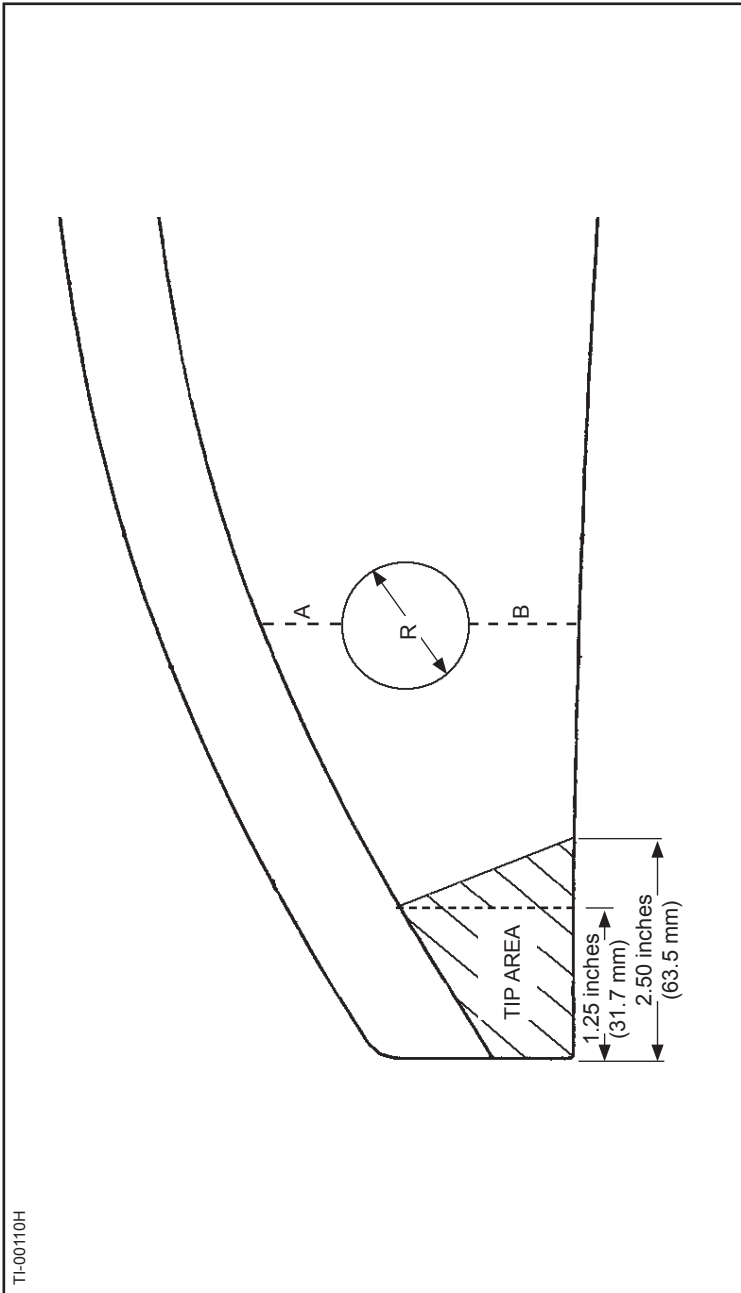

TI-00110H

N-shank Kevlar®/Carbon Hybrid Blade Limits
Figure 6-13.3, Page 1 of 4

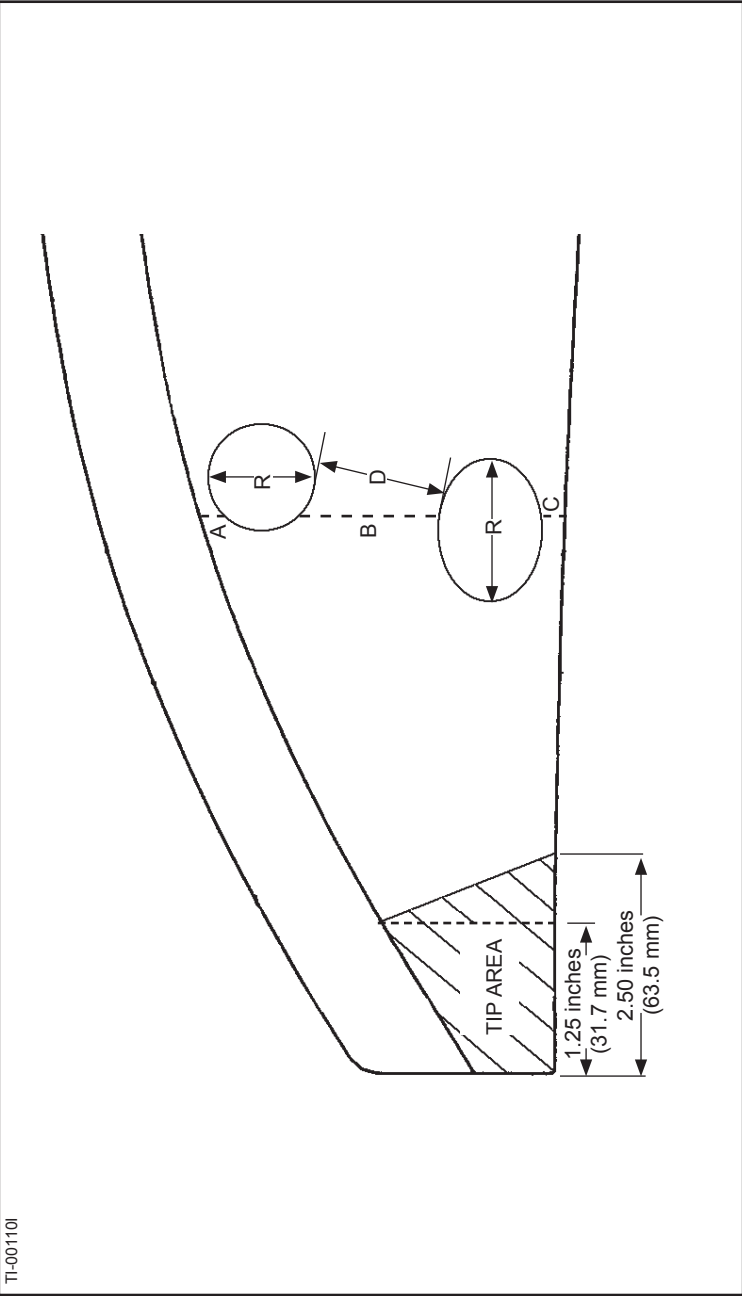

TI-001101

N-shank Kevlar®/Carbon Hybrid Blade Limits
Figure 6-13.3 , Page 2 of 4

T1-00110J

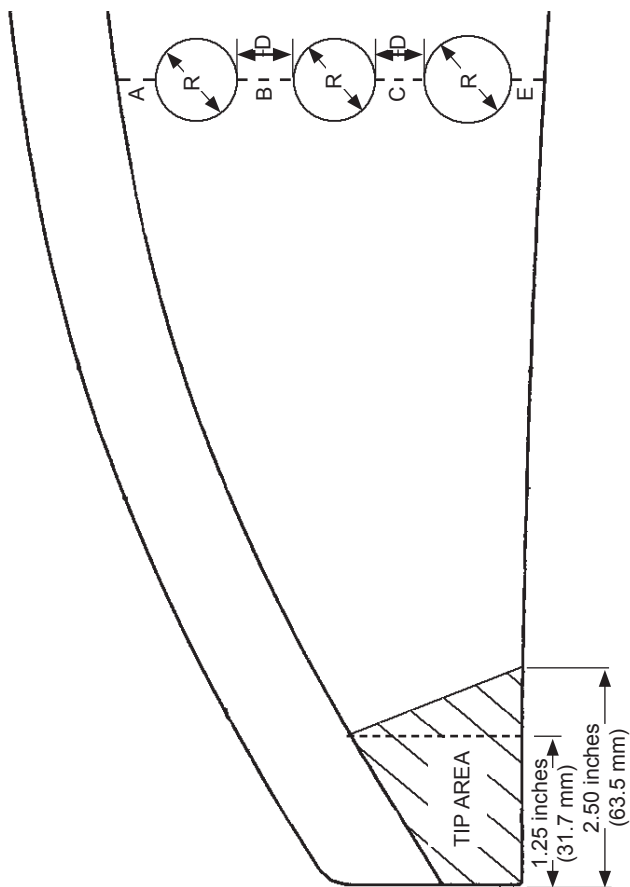

N-shank Kevlar®/Carbon Hybrid Blade Limits
Figure 6-13.3 , Page 3 of 4

TI-00110K

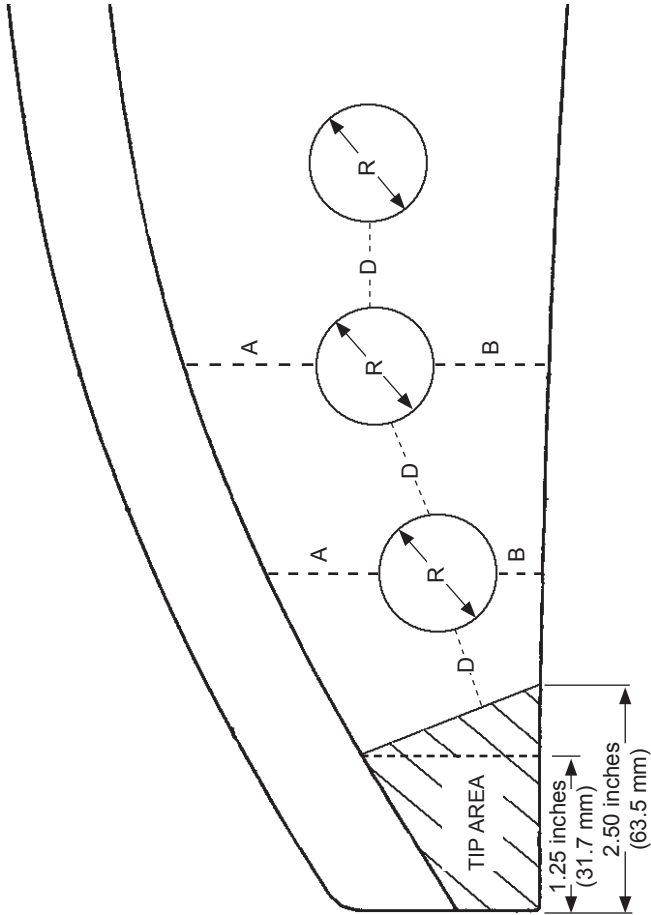

N-shank Kevlar®/Carbon Hybrid Blade Limits
Figure 6-13.3 , Page 4 of 4

10 Missing Expanded Foil Mesh

- a The expanded foil mesh may be missing in accordance with Figure 6-13.3.

11 Paint Erosion

The maximum permitted exposure of the composite material and/or the primer filler is 5.0 sq. inches (3225 sq. mm). This allowable does not refer to primer sealer.

- a For maintenance scheduling purposes, propellers with blades that show more than 5.0 sq. inches (3225 sq. mm) of paint erosion may continue in operation for an additional 250 hours or 1 (one) month, whichever occurs first.

12 Loss of Paint and/or Filler Material

- a Paint and/or filler material may be missing from the entire area of the erosion shield and the blade is considered airworthy.

(This page is intentionally blank.)

- (d) Blade Damage - For N-shank Carbon Blades Only
(Refer to Figure 6-13.2)
- 1 Gouge or Loss of Material - Outboard Region of the Blade
 - a The maximum permitted diameter or equivalent area (0.20 sq. inch or 129 sq. mm) of a gouge or loss of composite material is 0.500 inch (12.70 mm). The maximum permitted length of a gouge or loss of composite material is 2.5 inches (63 mm). The maximum permitted depth of a gouge or loss of composite material is 0.020 inch (0.50 mm).
 - 2 Gouge or Loss of Material - Trailing Edge Foam Region of the Blade
 - a The maximum permitted diameter or equivalent area of a gouge or loss of composite material is 0.500 inch (12.70 mm). The maximum permitted length is 2.5 inches (63 mm). The maximum permitted depth is 0.020 inch (0.50 mm). Exposed foam or a delamination is not permitted.
 - 3 Gouge or Loss of Material - Inboard Region of the Blade
 - a A gouge or loss of composite material on the inboard region of the blade is unairworthy damage.
 - 4 Delamination - Outboard Region of the Blade
 - a The maximum permitted area of delamination is 2.0 square inches (1290 sq. mm).
 - 5 Delamination - Trailing Edge Foam Region of the Blade
 - a The maximum permitted area of delamination is 2.0 square inches (1290 sq. mm).
 - 6 Delamination - Inboard Region of the Blade
 - a A delamination on the inboard region of the blade is unairworthy damage.

- 7 Split Trailing Edge - Tip and Trailing Edge Region of the Blade
 - a The maximum permitted depth of a split area is 0.5 inch (12 mm). The maximum permitted length is 6.0 inches (152 mm). Damaged fibers or exposed foam are not permitted.
- 8 Split Trailing Edge - Inboard Region of the Blade
 - a A split trailing edge on the inboard region of the blade is unairworthy damage.
- 9 Crushed or Cracked Trailing Edge - Trailing Edge Foam Region of the Blade
 - a The maximum permitted depth of a crushed or cracked area is 0.25 inch (6.3 mm). The maximum permitted length of a crushed or cracked area is 2.0 inches (50 mm).

10 Paint Erosion

The maximum permitted exposure of the composite material and/or the primer filler is 5.0 sq. inches (3225 sq. mm). This allowable does not refer to primer sealer.

- a For maintenance scheduling purposes, propellers with blades that show more than 5.0 sq. inches (3225 sq. mm) of paint erosion may continue in operation for an additional 250 hours or 1 (one) month, whichever occurs first.

(e) Propeller Ice Protection System

- 1 Refer to the Anti-ice and De-ice Systems chapter of this manual for propeller ice protection system inspections.

H. Unairworthy Damage

CAUTION: UNAIRWORTHY DAMAGE TO A HARTZELL COMPOSITE BLADE MUST BE REPAIRED BEFORE THE NEXT FLIGHT.

(1) Definition

Any damage that exceeds airworthy limits is considered unairworthy.

(2) Repair

(a) Areas of unairworthy damage must be repaired before further flight.

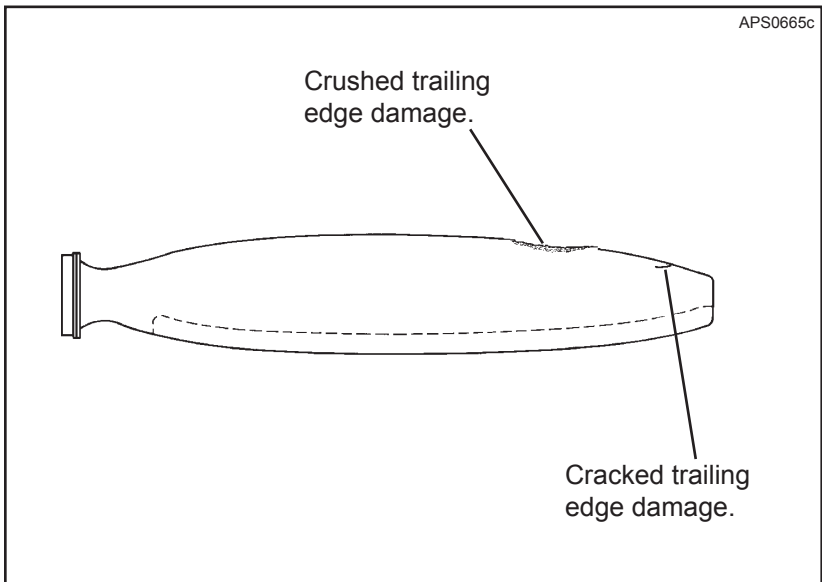

Crushed and Cracked Trailing Edge
Figure 6-14

TI-145003

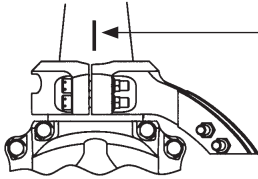

Inspect for cracks
in these areas
on the leading and
trailing edges
of the blade.

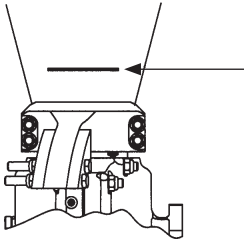
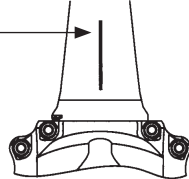

Inspect for cracks
in these areas
on the face and
camber sides
of the blade.

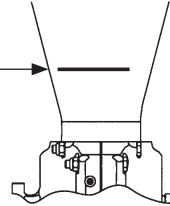

**Inspection Areas for Counterweighted
and Non-counterweighted Blades**
Figure 6-15

I. On Wing Blade Shank Inspection**(1) General**

(a) This Inspection is for Hartzell composite propeller blade models ()7690(), ()7890(), and ()7421() installed on an undampened or modified Lycoming (AE)IO-360 engine.

1 For the purposes of this inspection, “modified” refers to engines that have had changes that may effect the vibratory characteristics of the engine such as, but not limited to, increased compression ratio, changes to boost horsepower, aftermarket turbo chargers, running at higher than rated RPM, and removing dampeners.

(b) Hartzell composite propellers have been tested and found to have acceptable vibratory characteristics when installed on production configured, dampened (AE)IO-360 engines. Dampened engines have one sixth and one eighth order counterweight and are identified by the number 6 in the 4th suffix character. For example: (AE)IO-360-XXX6.

CAUTION: **UNDAMPENED OR MODIFIED
ENGINES CAN IMPOSE VIBRATORY
STRESS INTO THE PROPELLER
BLADES WHICH EXCEED THE
DESIGN ALLOWABLES.**

(c) Composite blades in a propeller installed on an undampened or modified Lycoming (AE)IO-360 engine may exhibit stress cracking or other vibration induced damage in the shank and/or counterweight area of the blade.

(2) Inspection Procedures

(a) Remove the spinner. Refer to the Spinner Removal section in the Installation and Removal chapter of this manual.

(b) Perform an on wing inspection of the blade shank for cracks in the blade shank area as shown in Figure 6-15.

1 If the blade has counterweights, inspect around the blade shank and counterweight assembly.

- (c) If no cracks are visible:
- 1 Reinstall the spinner. Refer to the Spinner Installation section in the Installation and Removal chapter of this manual.
 - 2 Make an entry in the logbook indicating compliance with this inspection and indicate when the next inspection is due.
- (d) If a crack is present:
- 1 Replace the blade before further flight. Refer to a propeller service facility that is licensed by a governmental agency, e.g., FAA, EASA, CAA.
 - 2 Make a report to the airworthiness authorities and Hartzell Propeller Inc. Product Support.

APS0665E

Brown stain on the erosion shield from lightning strike.



Evidence of Lightning Strike Damage to Composite Blade
Figure 6-16

J. Lightning Strike Damage - Refer to Figure 6-16.

CAUTION 1: ANY COMPOSITE BLADE SUSPECTED OF LIGHTNING STRIKE MUST BE INSPECTED AND MAY REQUIRE OVERHAUL.

CAUTION 2: CONSULT AIRFRAME MANUFACTURER'S MANUALS. THERE MAY BE ADDITIONAL REQUIREMENTS SUCH AS ICE PROTECTION SYSTEM CHECKS TO PERFORM IN THE EVENT OF PROPELLER LIGHTNING STRIKE.

NOTE: Lightning usually enters the propeller through the metal erosion shield of a blade. The charge typically enters at the tip of the blade and travels through the erosion shield toward the hub. The charge exits the erosion shield at the inboard end and enters the next conductive element in the path.

(1) Visual Inspection

- (a) If a lightning strike is suspected, perform a thorough visual inspection, looking for the indications of a lightning strike.
- (b) If a lightning strike is present, a darkened area and possible pitting, usually in proximity of the tip and at the most inboard end of the metal erosion shield, will be noticeable. Refer to Figure 6-16.
- (c) If the blade has a anti-icing or de-ice boot installed, it may be debonded from the erosion shield due to the strike. In any case, the propeller ice protection system may be damaged.
- (d) Lightning strikes may also cause one or all of the following: debonding, lifting, and buckling of the metal erosion shield and delamination and splitting of the laminate.
- (e) If no evidence of a lightning strike exists, then further maintenance action is not required.

(2) Additional Inspection

CAUTION: IF EVIDENCE OF A LIGHTNING STRIKE IS DISCOVERED, FURTHER INSPECTION IS REQUIRED BEFORE FURTHER FLIGHT.

- (a) A propeller may be permitted to be operated for an additional ten (10) hours before disassembly and inspection in accordance with the applicable overhaul manual. The additional ten (10) hours are permitted if the propeller and blades are not severely damaged, and if the blades meet airworthiness criteria discussed earlier in this section.

CAUTION: CONSULT AIRFRAME MANUFACTURER'S MANUALS. THERE MAY BE ADDITIONAL REQUIREMENTS, SUCH AS PROPELLER ICE PROTECTION SYSTEM CHECKS, TO PERFORM IN THE EVENT OF PROPELLER LIGHTNING STRIKE.

(b) Procedure for Temporary Operation

- 1** Remove the spinner dome and perform a visual inspection of the propeller, spinner, and propeller ice protection system, looking for evidence of significant damage that would require repair before flight (such as broken de-ice wires or arcing damage to the propeller hub).
- 2** Perform visual and coin tap inspections of the composite blades that have indications of arcing. If the damage is minor and does not exceed airworthy damage limits specified earlier in this section, then operation for ten (10) hours is permitted before disassembly and inspection in accordance with the applicable overhaul manual.

(c) Required inspection in the event of a lightning strike.

- 1** Disassemble the propeller and inspect it in accordance with the applicable overhaul manual. This procedure must be performed by FAA approved personnel.

K. Minor Repair

- (1) A complete description of minor repair techniques, tools, and materials is available in Hartzell Propeller Inc. Composite Blade Manual 135F (61-13-35).
- (2) Use only those repair techniques, tools and materials described in Hartzell Propeller Inc. Composite Blade Manual 135F (61-13-35). Substitution of materials described in Manual 135F is not permitted, i.e., the use of "Quick Setting" epoxies, unless described in Hartzell Propeller Inc. Composite Blade Manual 135F (61-13-35), is not permitted when performing blade repairs.

5. Painting of Composite Blades

A. General

- (1) Propeller blades are painted with a durable specialized coating that is resistant to abrasion. If this coating becomes eroded, it is necessary to repaint the blades to provide proper corrosion and erosion protection. Painting should be performed by an authorized propeller repair station in accordance with Hartzell Propeller Inc. Standard Practices Manual 202A (61-01-02).
- (2) It is permitted to perform a blade touch-up with aerosol paint in accordance with the procedures in section 5.B. Painting of Composite Blades in this chapter.
- (3) Refer to Table 6-2 for paints that are approved for blade touch-up.

Vendor	Color/Type	Vendor P/N	Hartzell Propeller Inc. P/N
Tempo	Epoxy Black	A-150	A-6741-145-2
Tempo	Epoxy Gray	A-151	A-6741-146-2
Tempo	Epoxy White (tip stripe)	A-152	A-6741-147-2
Tempo	Epoxy Red (tip stripe)	A-153	A-6741-149-2
Tempo	Epoxy Yellow (tip stripe)	A-154	A-6741-150-2
Sherwin-Williams	Black	F75KXB9958-4311	A-6741-145-1
Sherwin-Williams	Gray	F75KXA10445-4311	A-6741-146-1
Sherwin-Williams	Gray Metallic	F75KXM9754-4311	A-6741-148-1
Sherwin-Williams	White (tip stripe)	F75KXW10309-4311	A-6741-147-1
Sherwin-Williams	Red (tip stripe)	F75KXR12320-4311	A-6741-149-1
Sherwin-Williams	Yellow (tip stripe)	F75KXY11841-4311	A-6741-150-1
Sherwin-Williams	Silver Metallic	F75KXS13564-4311	A-6741-163-1
Sherwin-Williams	Silver	F75KXS13564-4311	A-6741-190-1
Sherwin-Williams	Bright Red	1326305	A-6741-200-5
Sherwin-Williams	Bright Yellow	1326313	A-6741-201-5
Sherwin-Williams	Bright Silver	1334259	A-6741-203-5
Sherwin-Williams	Prop Gold	F63TXS17221-4311	A-6741-204-5

Approved Touch-up Paints
Table 6-2

- (4) The paint manufacturers may be contacted using the following information:

Tempo Products Co.

A plasti-kote Company
1000 Lake Road
Medina, OH 44256
Tel: 800.321.6300
Fax: 216.349.4241
Cage Code: 07708

Sherwin Williams Co.

2390 Arbor Boulevard
Dayton, Ohio
Tel: 937.298.8691
Fax: 937.298.3820
Cage Code: 0W199

B. Procedure

WARNING: CLEANING AGENTS (ACETONE, #700 LACQUER THINNER, AND MEK), ARE FLAMMABLE AND TOXIC TO THE SKIN, EYES AND RESPIRATORY TRACT. SKIN AND EYE PROTECTION IS REQUIRED. AVOID PROLONGED CONTACT. USE IN WELL VENTILATED AREA.

CAUTION: ANY REFINISHING PROCEDURE CAN ALTER PROPELLER BALANCE. PROPELLERS THAT ARE OUT OF BALANCE MAY EXPERIENCE EXCESSIVE VIBRATIONS WHILE IN OPERATION.

- (1) Using a clean cloth moistened with acetone, #700 lacquer thinner, or MEK, wipe the surface of the blade to remove any contaminants. Permit the solvent to evaporate.
- (2) Using 120 to 180 grit sandpaper, sand to feather the existing coatings away from the eroded or repaired area.
- (a) Erosion damage is typically very similar on all blades in a propeller assembly. If one blade has more extensive damage, e.g. in the tip area, sand all the blades in the tip area to replicate the repair of the most severely damaged blade tip. This practice is essential in maintaining balance after refinishing.
- (3) Using lacquer thinner 700 or MEK, wipe the surface of the blade, and permit to evaporate.

- (4) Apply masking material to the erosion shield, anti-icing or de-ice boot and tip stripes, as needed.

WARNING: FINISH COATINGS ARE FLAMMABLE AND TOXIC TO THE SKIN, EYES AND RESPIRATORY TRACT. SKIN AND EYE PROTECTION ARE REQUIRED. AVOID PROLONGED CONTACT. USE IN A WELL VENTILATED AREA.

CAUTION: APPLY FINISH COATING ONLY TO THE DEGREE REQUIRED TO UNIFORMLY COVER THE REPAIR/EROSION. AVOID EXCESSIVE PAINT BUILDUP ALONG THE TRAILING EDGE TO AVOID CHANGING THE BLADE PROFILE AND/OR P-STATIC CHARACTERISTICS.

- (5) Apply a sufficient amount of finish coating to achieve 2 to 4 mil thickness when dry.
- (a) Re-coat before 30 minutes, or after 48 hours.
 - (b) If the paint is permitted to dry longer than four (4) hours, it must be lightly sanded before another coat is applied.
- (6) Remove the masking material from tip stripes and re-apply masking material for tip stripe refinishing.
- (7) Apply sufficient tip stripe coating to achieve 2 to 4 mil thickness when dry.
- (a) Re-coat before 30 minutes, or after 48 hours. Remove masking material immediately.
 - (b) If the paint is permitted to dry longer than four (4) hours, it must be lightly sanded before another coat is applied.
- (8) Remove the masking immediately from the anti-icing or de-ice boot and tip stripes, if required.
- (9) Optionally, perform dynamic balancing in accordance with the procedures and limitations specified in the Dynamic Balance section of this chapter.

C. Optional Removal of Leading Edge Paint for N7605(B,K) and N7605C() Blades

- (1) Measure from the tip of the blade as shown in Figure 6-16.1.
- (2) Make a marked line that is 0.25 inch (6.3 mm) from the leading edge along the area as shown in Figure 6-16.1.
- (3) Apply masking material (electrical tape) along the marked line as shown in Figure 6-16.1.
- (4) Using 240 grit or finer sandpaper, remove the paint and primer from the area between the leading edge and the masking material.
- (5) Using 400 or finer grit sandpaper, sand the area between the leading edge and the masking material.
- (6) Using a medium or fine abrasive pad, for example Scotchbrite®, finish the sanded area.
- (7) Remove the masking material from the blade.

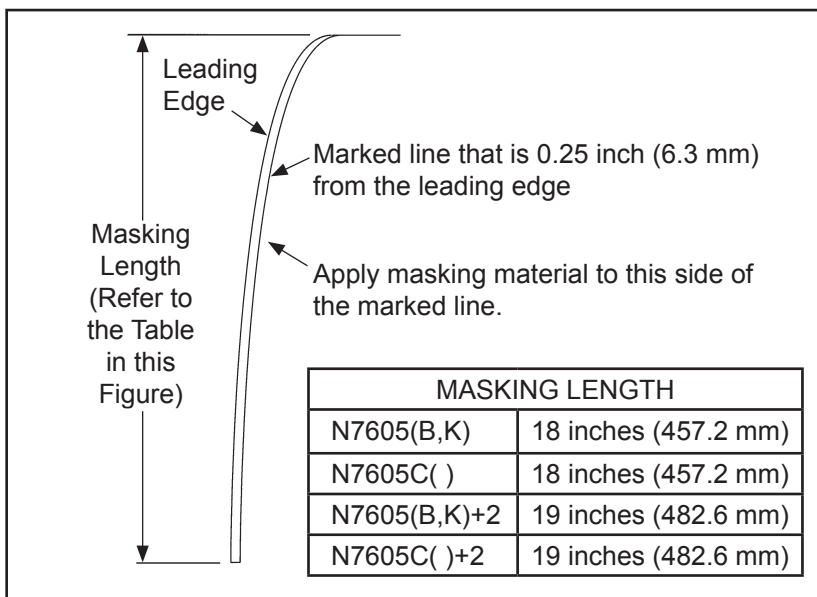

Removal of the Leading Edge Paint
Figure 6-16.1

WARNING: CLEANING AGENTS (ACETONE, #700 LACQUER THINNER, AND MEK), ARE FLAMMABLE AND TOXIC TO THE SKIN, EYES AND RESPIRATORY TRACT. SKIN AND EYE PROTECTION IS REQUIRED. AVOID PROLONGED CONTACT. USE IN WELL VENTILATED AREA.

- (8) Using a clean cloth moistened with acetone, #700 lacquer thinner, or MEK, wipe the blade clean.

(This page is intentionally blank.)

6. Dynamic Balance**A. Overview**

CAUTION: IF REFLECTIVE TAPE IS USED FOR DYNAMIC BALANCING, REMOVE THE TAPE IMMEDIATELY AFTER BALANCING IS COMPLETED.

NOTE: Dynamic balance is recommended to reduce vibrations that may be caused by a rotating system (propeller and engine) imbalance. Dynamic balancing can help prolong the life of the propeller, engine, airframe, and avionics.

- (1) Dynamic balance is accomplished by using an accurate means of measuring the amount and location of the dynamic imbalance.
- (2) The number of balance weights installed must not exceed the limits specified in this chapter.
- (3) Follow the dynamic balance equipment manufacturer's instructions for dynamic balance in addition to the specifications in this chapter.

NOTE: Some engine manufacturers' instructions also contain information about dynamic balance limits.

B. Inspection Procedures Before Balancing

- (1) Visually inspect the propeller assembly before dynamic balancing.

NOTE: The first run-up of a new or overhauled propeller assembly may leave a small amount of grease on the blades and inner surface of the spinner dome.

- (a) Using Stoddard solvent (or equivalent), completely remove any grease on the blades or inner surface of the spinner dome.
- (b) Visually examine each propeller blade assembly for evidence of grease leakage.
- (c) Visually examine the inner surface of the spinner dome for evidence of grease leakage.

- (2) If there is no evidence of grease leakage, lubricate the propeller in accordance with the Maintenance Practices chapter in this manual. If grease leakage is evident, determine the location of the leak and correct before re-lubricating the propeller.

- (3) Before dynamic balancing, record the number and location of all balance weights.

- (4) Static balance is accomplished at a propeller overhaul facility when an overhaul or major repair is performed.

NOTE: If static balancing is not accomplished before dynamic balancing, the propeller may be so severely unbalanced that dynamic balance may be unachievable because of measurement equipment limitations.

C. Modifying Spinner Bulkhead to Accommodate Dynamic Balance Weights

CAUTION: ALL HOLE/BALANCE WEIGHT LOCATIONS MUST TAKE INTO CONSIDERATION, AND MUST AVOID, ANY POSSIBILITY OF INTERFERING WITH THE ADJACENT AIRFRAME, PROPELLER ICE PROTECTION SYSTEM, AND ENGINE COMPONENTS.

- (1) It is recommended that balance weights be placed in a radial location on aluminum spinner bulkheads that have not been previously drilled.
- (2) The radial location should be outboard of the de-ice slip ring or bulkhead doubler and inboard of the bend where the bulkhead creates the flange surface to attach the spinner dome.
- (3) Twelve equally spaced locations are recommended for weight attachment.
- (4) Installing nut plates (10-32 thread) of the type used to attach the spinner dome will permit convenient balance weight attachment on the engine side of the bulkhead.
- (5) Alternatively, drilling holes for use with the AN3-() type bolts with self-locking nuts is permitted.
- (6) Chadwick-Helmuth Manual AW-9611-2, "The Smooth Propeller", specifies several generic bulkhead rework procedures. These are permitted if they comply with the conditions specified herein.

D. Placement of Balance Weights for Dynamic Balance

- (1) The preferred method of attachment of dynamic balance weights is to add the weights to the spinner bulkhead.

NOTE: Many spinner bulkheads have factory installed self-locking nut plates provided for this purpose.

- (2) If the location of static balance weights has not been altered, subsequent removal of the dynamic balance weights will return the propeller to its original static balance condition.
- (3) Use only stainless or plated steel washers as dynamic balance weights on the spinner bulkhead.
- (4) Do not exceed a maximum weight per location of 0.9 oz. (25.5 g).

NOTE: This is approximately equal to six AN970 style washers (0.188 inch ID, 0.875 inch OD, 0.063 inch thickness) (4.78 mm ID, 22.23 mm OD, 1.60 mm thickness).

- (5) Install weights using aircraft quality #10-32 or AN-3 () type screws or bolts.
- (6) Balance weight screws attached to the spinner bulkhead must protrude through the self-locking nuts or nut plates a minimum of one thread and a maximum of four threads.
 - (a) It may be necessary to alter the number and/or location of static balance weights to achieve dynamic balance.
- (7) Unless otherwise specified by the engine or airframe manufacturer, Hartzell recommends that the propeller be dynamically balanced to a reading of 0.2 IPS, or less.
- (8) If reflective tape is used for dynamic balancing, remove the tape immediately after balancing is completed.
- (9) Make a record in the propeller logbook of the number and location of dynamic balance weights, and static balance weights if they have been reconfigured.

(This page is intentionally blank.)

7. Propeller Low Pitch Setting

WARNING 1: RPM ADJUSTMENTS MUST BE MADE WITH REFERENCE TO A CALIBRATED TACHOMETER. AIRCRAFT MECHANICAL TACHOMETERS DEVELOP ERRORS OVER TIME, AND SHOULD BE PERIODICALLY RECALIBRATED TO MAKE SURE THE PROPER RPM IS DISPLAYED.

WARNING 2: LOW PITCH BLADE ANGLE ADJUSTMENTS MUST BE MADE IN ACCORDANCE WITH THE APPLICABLE TYPE CERTIFICATE OR SUPPLEMENTAL TYPE CERTIFICATE HOLDER'S MAINTENANCE DATA.

A. Low Pitch Stop - All Propeller Models

- (1) The propeller low pitch stop is set at the factory to the aircraft TC or STC Holder's requirements and should not require any additional adjustment. The TC or STC Holder provides the required low pitch stop blade angle and may also provide the acceptable RPM range for a maximum power static condition. Be aware that the aircraft TC or STC holder may specify the static RPM to be less than the RPM to which the engine is rated.
- (2) An overspeed at the maximum power static condition may indicate that the propeller low-pitch blade angle is set too low and that the governor is improperly adjusted.
- (3) An underspeed during the maximum power static condition may be caused by any one or a combination of the following: The propeller low pitch blade angle is too high; the governor is improperly adjusted; the engine is not producing rated power.

W10215.eps

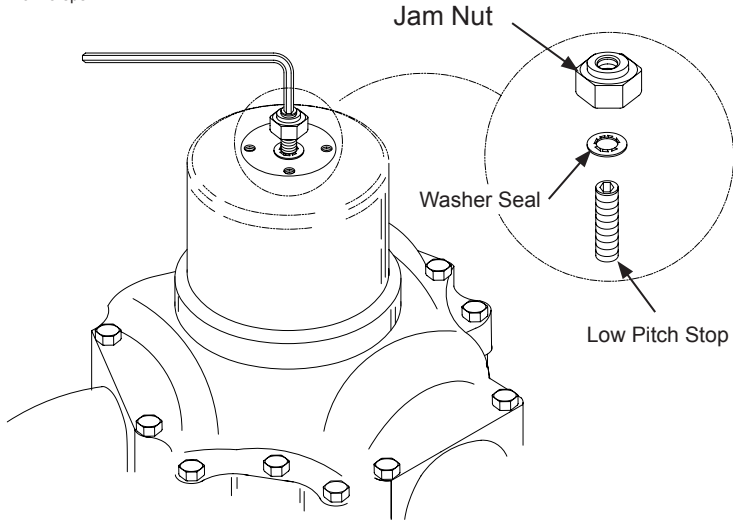

Low Pitch Stop Adjustment (-1, -4)
Figure 6-17

APS6154.eps

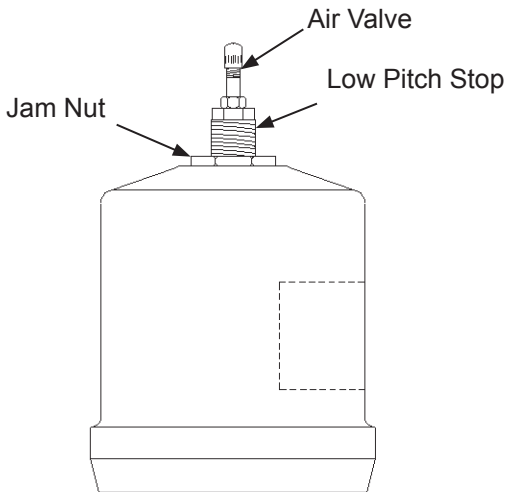

Low Pitch Stop Adjustment (-2)
Figure 6-18

B. Max. RPM (Static) Low Pitch Stop Adjustment

WARNING 3: SIGNIFICANT ADJUSTMENT OF THE LOW PITCH STOP TO ACHIEVE THE SPECIFIED STATIC RPM MAY MASK AN ENGINE POWER PROBLEM.

Refer to the following applicable procedure for accomplishing an adjustment to the low pitch angle:

(1) Non-Feathering (-1, -4) Low Pitch Stop Adjustment

(a) Refer to Figure 6-17. Loosen the jam nut while holding the low pitch stop with an allen wrench to prevent the low pitch stop from turning as the jam nut is loosened. Turning the low pitch stop in will increase blade pitch to reduce RPM, and turning the low pitch stop out will lower blade pitch and increase RPM. The low pitch stop has 24 threads per inch.

- 1** Turning the stop 3/4 of a turn (0.030 inch [0.762 mm] of linear travel) will change the blade pitch by approximately one degree. One degree of blade pitch will change engine RPM by approximately 140-150 RPM.
- 2** Turning the low pitch stop screw one revolution equals 0.042 inch (1.06 mm) of linear travel, and results in approximately 1.4 degree blade angle change. This blade angle change results in an RPM increase/decrease of approximately 200 RPM.

WARNING: A MINIMUM OF FIVE THREADS IN THE CYLINDER MUST ENGAGE THE LOW PITCH STOP AFTER ADJUSTMENT IS COMPLETED.

- (b) When the low pitch stop is adjusted, torque the low pitch stop jam nut in accordance with Torque Table 3-1.
- (c) Repeat the Static RPM Check in the Testing and Troubleshooting chapter of this manual.

(2) Feathering (-2,) Low Pitch Stop Adjustment

WARNING: AIR PRESSURE (-2 PROPELLERS)
MUST BE REDUCED TO 0 PSI
BEFORE ANY LOW PITCH
ADJUSTMENT MAY BE MADE.

(a) Refer to Figure 6-18. Loosen the jam nut while holding the low pitch stop with a second wrench to prevent the low pitch stop from turning as the jam nut is loosened. Turning the low pitch stop into the cylinder will increase blade pitch and reduce RPM, and turning the low pitch stop out of the cylinder will lower blade pitch and increase RPM. The low pitch stop has 20 threads per inch.

1 Turning the low pitch stop 2/3 of a turn (0.030 inch [0.762 mm] of linear travel) will change the blade pitch by approximately one degree. This blade angle change results in an RPM increase/decrease of approximately 140-150 RPM.

2 Turning the low pitch stop screw one full turn (0.050 inch [1.27 mm] of linear travel) will change the blade pitch approximately 1.7 degree. This blade angle change results in an RPM increase/decrease of approximately 250 RPM.

WARNING: A MINIMUM OF FIVE THREADS IN
THE CYLINDER MUST ENGAGE
THE LOW PITCH STOP AFTER
ADJUSTMENT IS COMPLETED.

(b) When the low pitch stop is adjusted, torque the low pitch stop jam nut in accordance with the Torque Table.

(c) Repeat the Static RPM Check in the Testing and Troubleshooting chapter of this manual.

8. Propeller High Pitch Settings
 - A. High Pitch (Min. RPM) Stop
 - (1) The high pitch stops are set at the factory per the aircraft manufacturer's recommendations. These stops are adjustable only by a certified propeller repair station or the Hartzell factory.
9. Start Lock Settings
 - A. Start Lock Pitch Stop
 - (1) The start lock pitch stops are set at the factory per the aircraft manufacturer's recommendations. These stops are adjustable only by an appropriately licensed propeller repair facility or the Hartzell factory.

10. Accumulator Part Number Change

A. General

- (1) The HC-C(2,3)YR-1A/7690() propeller with 8907-001 accumulator uses a standard accumulator, part number 8907-001.
- (2) This accumulator is charged, per Hartzell's specifications, to a lower pressure than that specified on the manufacturer's accumulator label. There is concern that these accumulators may subsequently be used on other installations with an improper air charge.
- (3) A new accumulator configuration, part number 8907-040, has been created. The label on this new part number accumulator specifies the reduced air pressure required for the propeller systems affected.
 - (a) The 8907-040 configuration is physically identical to the original 8907-001 accumulator.
- (4) This procedure changes the part number and labels to reidentify 8907-001 accumulators.

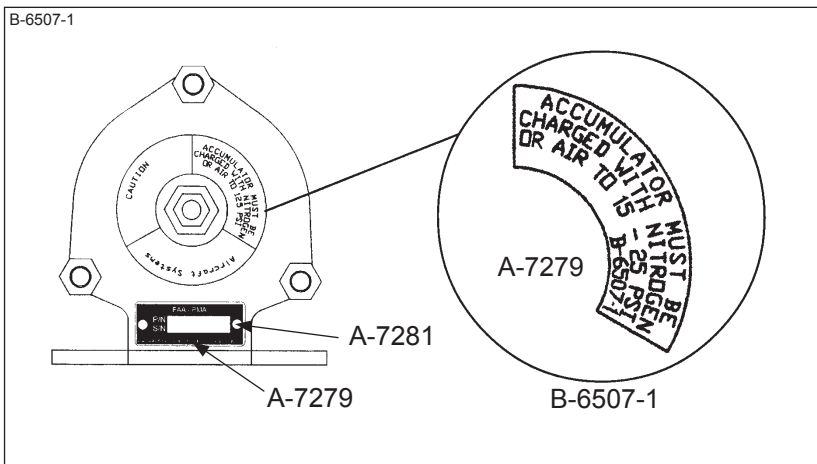

Accumulator Part Number Change
Figure 6-19

B. Material Information**(1) Material Necessary for Each Propeller/Component**

<u>Part Number</u>	<u>Keyword</u>	<u>Quantity</u>
A-7279	Nameplate	1
A-7281	Drive Lock Stud	2
B-6507-1	Label	2

C. Accomplishment Instructions**(1) Removal Instructions**

- (a) Remove the drive lock studs that fasten the original nameplate.

WARNING: THE SERIAL NUMBER MUST BE TRANSFERRED FROM THE ORIGINAL NAMEPLATE TO THE NEW NAMEPLATE TO PROVIDE FUTURE SERIAL NUMBER TRACEABILITY OF THIS COMPONENT.

- (b) Using a Vibra Engraving machine or equivalent, transfer the serial number from the original nameplate to the new A-7279 nameplate.

- (c) Discard the original nameplate.

(2) Installation Instructions

- (a) Using two A-7281 drive lock studs, install the new A-7279 nameplate that shows the transferred serial number.

- (b) Install B-6507-1 labels directly over original labels. Refer to Figure 6-19

- 1 The B-6507-1 label specifies an air charge of 15-25 psi. Apply the new label directly over the currently installed label to cover the air charge specified on the currently installed label.

11. Propeller Ice Protection Systems**A. Electric De-ice System**

- (1) Consult the Pilot Operating Handbook (including all supplements) regarding flight into conditions of known icing. The aircraft may not be certificated for flight in known icing conditions, even though propeller de-ice equipment is installed.
- (2) Refer to the Anti-ice and De-ice Systems chapter of this manual for functional tests of the de-ice system.

B. Anti-ice System

- (1) Consult the Pilot Operating Handbook (including all supplements) regarding flight into conditions of known icing. The aircraft may not be certificated for flight in known icing conditions, even though propeller anti-ice equipment is installed.
- (2) Refer to the Anti-ice and De-ice Systems chapter of this manual for functional tests of the anti-ice system.

12. Installation of Erosion Tape CM158**A. General**

- (a) This section provides the procedures for the installation of erosion tape CM158 on a blade that will not have an anti-icing or de-ice boot installed.
 - 1 For the installation of erosion tape CM158 on a blade that has a de-ice boot installed, refer to Hartzell Propeller Electrical De-ice Boot Removal and Installation Manual 182 (61-12-82).
 - 2 For the installation of erosion tape CM158 on a blade that has an anti-icing boot installed, refer to Hartzell Propeller Anti-icing Boot Removal and Installation Manual 183 (61-12-83).
- (b) Application of erosion tape CM158 is required for the blade models listed in Table 6-3.
- (c) Application of erosion tape CM158 is optional but highly recommended for all other models of composite blades.
- (d) A minimum temperature of 60°F (10°C) is required for erosion tape CM158 application.
- (e) Keep hands clean at all times.
- (f) Paint must cure for a minimum of 8 hours before installing erosion tape CM158.

B. Materials Required**(1) Consumables**

NOTE: For additional information about CM numbers or materials refer to the Consumable Materials chapter of Hartzell Standard Practices Manual 202A (61-01-02) or contact the Hartzell Propeller Inc. Product Support Department.

- (a) Erosion Tape CM158, Hartzell part number A-6741-168
- (b) Methyl-Ethyl-Keytone (MEK) CM106, Methyl Propyl Ketone (MPK) CM219, or Acetone CM173
- (c) Cheesecloth, Grade 90 CM159, locally procured
- (d) Masking Tape, locally procured
- (e) 3M Adhesive Promoter 86A, CM124, optional

(2) Tools

NOTE: For additional information about TE numbers or materials in this manual refer to the Hartzell Illustrated Tool and Equipment Manual 165 (61-00-65) or contact the Hartzell Propeller Inc. Product Support Department.

- (a) Ball Point Pen or Pencil, locally procured
- (b) Measuring Tape, locally procured
- (c) Rubber Roller TE330 or Silicon Roller TE331

Blade Model	Tape Length (per Blade)
N7605-() or N7605C-() that does not have a de-ice or anti-icing boot installed	14.875 inches (377.82 mm)

**Erosion Tape
Table 6-3**

C. Installation Procedure

WARNING: ADHESIVES AND SOLVENTS ARE FLAMMABLE AND TOXIC TO THE SKIN, EYES, AND RESPIRATORY TRACT. SKIN AND EYE PROTECTION ARE REQUIRED. AVOID PROLONGED CONTACT AND BREATHING OF VAPORS. USE SOLVENT RESISTANT GLOVES TO MINIMIZE SKIN CONTACT AND WEAR SAFETY GLASSES FOR EYE PROTECTION. USE IN A WELL VENTILATED AREA AWAY FROM SPARKS AND FLAME.

CAUTION: DO NOT INSTALL EROSION TAPE CM158 ON A BLADE THAT HAS PAINT THAT HAS CURED LESS THAN 8 HOURS.

(1) Preparation

- (a) Cut the appropriate length of erosion tape CM158 in accordance with Table 6-3.
- (b) Radius the corners of the erosion tape CM158 to 0.5 inch (13 mm) to remove any sharp corners.
- (c) Using a pencil or a ball point pen, measure and make a mark on the nonadhesive side of the erosion tape CM158 to indicate the centerline of the erosion tape.
- (d) Using a non-graphite pencil CM162 or equivalent, measure and make a mark on the blade 1.00 inch (25.4 mm) outboard of the metal blade shank near the leading edge.
 - 1 This alignment mark on the blade will be used to align the inboard edge of the erosion tape at installation.
- (e) Using a clean cloth dampened with solvent CM106 (MEK), CM219 (MPK), or CM41 (toluene) thoroughly clean the area of the blade where the erosion tape CM158 will be installed.
 - 1 Using a clean, lint-free cloth, immediately wipe the area dry.
 - 2 Permit the area to air dry.
 - 3 Repeat the cleaning and drying of the area.

(2) Application of Optional Adhesive Promoter CM124

NOTE: Adhesive promoter CM124 will increase the adhesion between the erosion tape CM158 and the blade.

- (a) Using masking tape or equivalent as masking material, apply the masking material to the perimeter of the area where the erosion tape CM158 will be installed.
- (b) Apply a thin, uniform layer of adhesive promoter CM124 to the area of the blade where the erosion tape CM158 will be installed.
- (c) Remove the masking material.

CAUTION: THE ADHESIVE PROMOTER CM124 WILL BEGIN TO LOSE ADHESION AFTER 60 MINUTES AT ROOM TEMPERATURE.

- (d) Permit the adhesive promoter CM124 to dry at room temperature for a minimum of 15 minutes and a maximum of 60 minutes.

(3) Installation of the Erosion Tape CM158

- (a) Peel the backing material from the erosion tape CM158.
- (b) Holding the erosion tape CM158 with the adhesive side toward the blade, align the end of the erosion tape with the the alignment mark on the blade (outboard of the metal shank and near the leading edge), while aligning the centerline that was marked on the erosion tape with the leading edge of the blade.
- (c) Press the erosion tape CM158 into position on the leading edge of the blade while maintaining light tension on the erosion tape to minimize air bubbles and keep the tape straight.
- (d) Using a roller, such as TE330 or TE331, or fingers, press the erosion tape CM158 down onto the leading edge of the blade.

- (e) Using a roller, such as TE330 or TE331, or fingers, work the erosion tape CM158 into position on one side of the blade.
- 1 Starting at the outboard end of the blade and working toward the shank, use a hard rubber or nylon roller, such as TE330 or TE331, or fingers to firmly seat the erosion tape CM158 to the blade.
 - 2 Make sure that there are no wrinkles and that no air is trapped under the erosion tape CM158.

CAUTION: DO NOT DAMAGE THE BLADE
WHEN REMOVING AIR BUBBLES.

- 3 Remove air bubbles under the erosion tape by carefully puncturing the erosion tape CM158 with a sharp pin and pressing out the trapped air.
- (f) Repeat the procedure on the other side of the blade.

(This page is intentionally blank.)

ANTI-ICE AND DE-ICE SYSTEMS - CONTENTS

1. Introduction.....	7-3
A. Propeller De-ice System	7-3
B. Propeller Anti-ice System.....	7-3
2. System Description.....	7-4
A. De-ice System.....	7-4
B. Anti-ice System	7-5
3. De-ice System Functional Tests	7-6
4. Anti-ice System Functional Tests.....	7-6
5. De-ice and Anti-ice System Inspections	7-7
A. De-ice System Inspections	7-7
B. Anti-ice System Inspections.....	7-7
6. De-ice and Anti-ice System Troubleshooting.....	7-8
A. De-ice System Troubleshooting	7-8
B. Anti-ice System Troubleshooting	7-8

(This page is intentionally blank.)

1. Introduction**A. Propeller De-ice System**

- (1) A propeller de-ice system is a system that removes ice after it forms on the propeller blades. A de-ice system uses electrical heating elements to melt the ice layer next to the blades, permitting the ice to be thrown from the blade by centrifugal force. Blades are alternately heated and permitted to cool as the current is applied and removed automatically by the de-ice system timer.
- (2) System components include a timer or cycling unit, electrical slip ring(s), brush block assembly, and blade mounted de-ice boots.

B. Propeller Anti-ice System

- (1) A propeller anti-ice system is a system that prevents formation of ice on propeller surfaces. An anti-ice system dispenses a fluid that mixes with, and reduces the freezing point of, moisture on the propeller blades. The mixture may then flow off the blades before it forms ice.
- (2) System components include a fluid tank, pump, slinger ring, and blade mounted fluid feed shoes.

2. System Description**A. De-ice System**

NOTE: Because of the wide variances of various de-ice systems, the following description is general in nature. Consult the airframe manufacturer's manual for a description of your specific de-ice system and controls.

The de-ice system is controlled by the pilot via a cockpit control switch. This switch applies power to the de-ice system, which will operate as long as the switch is in the ON position. Depending upon the system, another set of cockpit controls may be available. One of these controls is a mode selector, which allows the pilot to select two cycling speeds, for heavy or light icing conditions. Some systems on twin engine aircraft have a switch that provides a full de-ice mode, which permits the pilot to de-ice both propellers simultaneously. This switch may only be used for short periods and is used when ice builds up on the propeller before the system is turned on.

An ammeter, which indicates current drawn by the system, is normally located near the de-ice system switches. This meter may indicate total system load, or a separate meter may be supplied for each propeller.

A timer, which is turned off and on by the cockpit control, is used to sequence the de-ice system. This timer turns the de-ice system on and off in proper sequence, controlling the heating interval for each propeller and making sure of even de-icing.

A brush block immediately behind the propeller supplies electrical current to the de-ice boot on each propeller blade via a slip ring. The slip ring is normally mounted on the spinner bulkhead.

When the pilot places the de-ice system cockpit control switch in the ON position, the system timer begins to operate. As the timer sequences, power is delivered to a power relay. The power relay delivers high current to the brush block and slip ring. Each propeller is de-iced in turn by the timer.

B. Anti-ice System

The anti-ice system is controlled by the pilot via a cockpit mounted rheostat. This rheostat operates a pump that pumps anti-ice fluid from the tank at a controlled rate.

The anti-ice fluid is delivered through a filter, a check valve, and then through tubing to a slinger ring located at the rear of the spinner bulkhead. The anti-ice fluid is dispensed into the rotating slinger ring, which holds the fluid in a curved channel by centrifugal force. The fluid then flows out of the slinger ring through feed tubes which are welded to the slinger ring, and then out onto the blade feed shoes.

The blade feed shoes are ridged rubber sheets which are glued to the leading edge of the blades. The ridges in the shoes direct the fluid out onto the blades and allow for an even distribution of the anti-ice fluid across the blades.

3. De-ice System Functional Tests
 - A. Functional tests of the de-ice system should be performed in accordance with the following Hartzell Manuals, which are available on the Hartzell Propeller website at www.hartzellprop.com:
 - (1) Hartzell Manual No. 181 (30-60-81) - Propeller Ice Protection System Component Maintenance Manual
 - (2) Hartzell Manual No. 182 (61-12-82) - Propeller Electrical De-ice Boot Removal and Installation Manual

4. Anti-ice System Functional Tests
 - A. Operational Checks of the anti-ice system should be performed in accordance with the following Hartzell Manuals, which are available on the Hartzell Propeller website at www.hartzellprop.com:
 - (1) Hartzell Manual No. 181 (30-60-81) - Propeller Ice Protection System Component Maintenance Manual
 - (2) Hartzell Manual No. 183 (61-12-83) - Propeller Anti-icing Boot Removal and Installation Manual

5. De-ice and Anti-ice System Inspections

The inspections detailed below are made on a regular basis, either before flight, during the 100 hour inspection, or if a problem is noted. Possible corrections to problems discovered during inspections, additional inspections, and limits are detailed in the following Hartzell manuals.

A. De-ice System Inspections

(1) Perform inspections in accordance with the following Hartzell Manuals, which are available on the Hartzell Propeller website at www.hartzellprop.com:

- (a) Hartzell Manual No. 181 (30-60-81) - Propeller Ice Protection System Component Maintenance Manual
- (b) Hartzell Manual No. 182 (61-12-82) - Propeller Electrical De-ice Boot Removal and Installation Manual.

B. Anti-ice System Inspections

(1) Perform inspections in accordance with the following Hartzell Manuals, which are available on the Hartzell Propeller website at www.hartzellprop.com:

- (a) Hartzell Manual No. 181 (30-60-81) - Propeller Ice Protection System Component Maintenance Manual
- (b) Hartzell Manual No. 183 (61-12-83) - Propeller Anti-icing Boot Removal and Installation Manual

6. De-ice and Anti-ice System Troubleshooting
- A. De-ice System Troubleshooting
- (1) Perform troubleshooting in accordance with the following Hartzell Manuals, which are available on the Hartzell Propeller website at www.hartzellprop.com:
- (a) Hartzell Manual No. 181 (30-60-81) - Propeller Ice Protection System Component Maintenance Manual
- (b) Hartzell Manual No. 182 (61-12-82) - Propeller Electrical De-ice Boot Removal and Installation Manual
- B. Anti-ice System Troubleshooting
- (1) Perform troubleshooting in accordance with the following Hartzell Manuals, which are available on the Hartzell Propeller website at www.hartzellprop.com:
- (a) Hartzell Manual No. 181 (30-60-81) - Propeller Ice Protection System Component Maintenance Manual
- (b) Hartzell Manual No. 183 (61-12-83) - Propeller Anti-icing Boot Removal and Installation Manual

CONTENTS

1. Introduction..... 803

2. Record Keeping..... 803

 A. Information to be Recorded 803

 B. Blade Damage Repair Sheets 803

 ()7690E 804

 B7421() 807

 7890() 810

 ()7690() 813

 N()7893() 817

 N7605() 820

 N7605C() 823

(This page is intentionally blank.)

1. Introduction

Federal Aviation Regulations require that a record be kept of any repairs, adjustments, maintenance, or required inspections performed on a propeller or propeller system.

This chapter provides a method for maintaining these records. It also provides a location for recording information which can aid the service technician in maintaining the propeller system.

2. Record Keeping**A. Information to be Recorded**

- (1) Information which is required to be recorded is listed in Part 43 of the U.S. Federal Aviation Regulations.
- (2) The log book may also be used to record:
 - (a) Propeller position (on aircraft)
 - (b) Propeller model.
 - (c) Propeller serial number
 - (d) Blade design number
 - (e) Blade serial numbers
 - (f) Spinner assembly part number.
 - (g) Propeller pitch range
 - (h) Aircraft information (aircraft type, model, serial number and registration number).

B. Blade Damage Repair Sheets

NOTE: The use of the Blade Damage Repair Sheets in this chapter is at the discretion of the user.

Record of () 7690E Composite Blade Damage Repair

Blade Serial No. _____

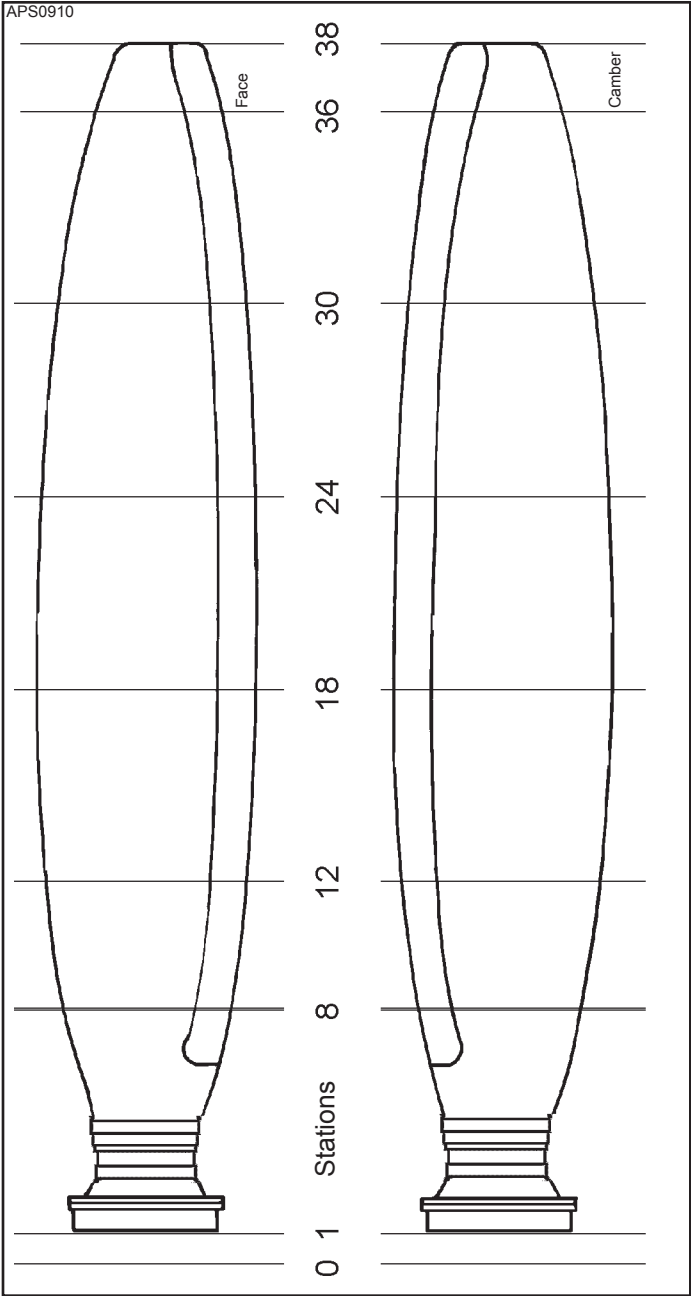

Record of () 7690E Composite Blade Damage Repair

Blade Serial No. _____

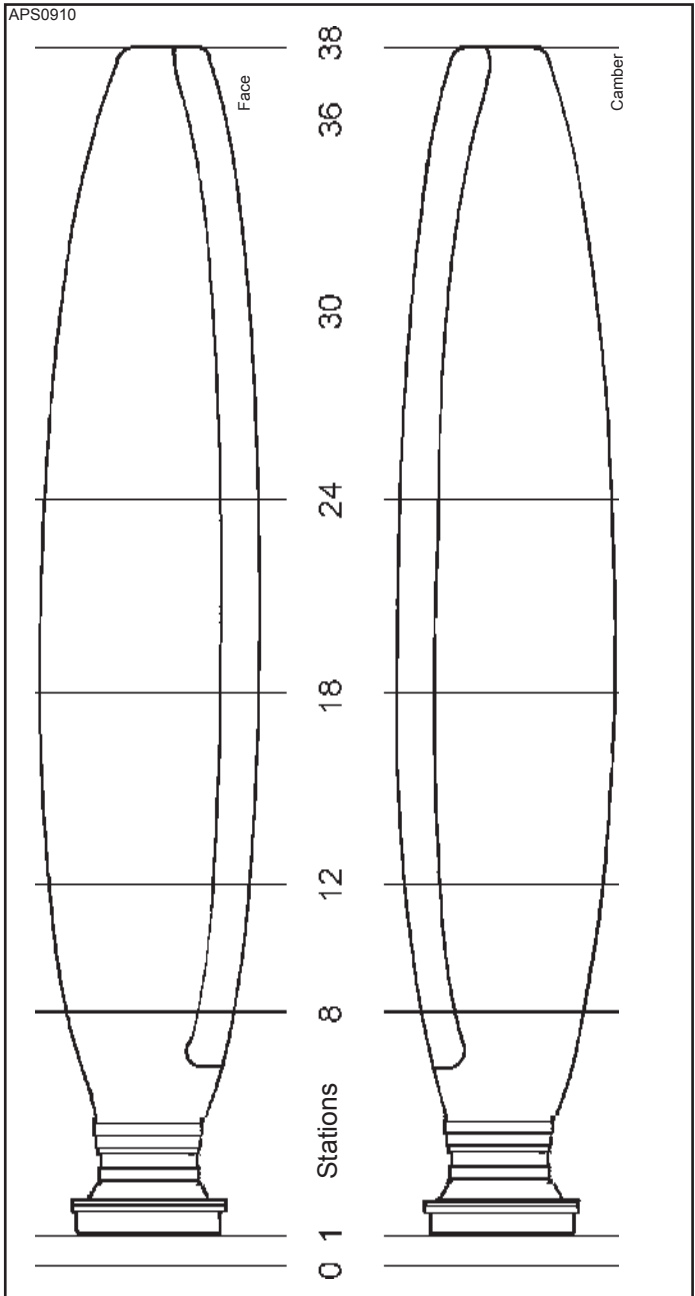

Record of () 7690E Composite Blade Damage Repair

Blade Serial No. _____

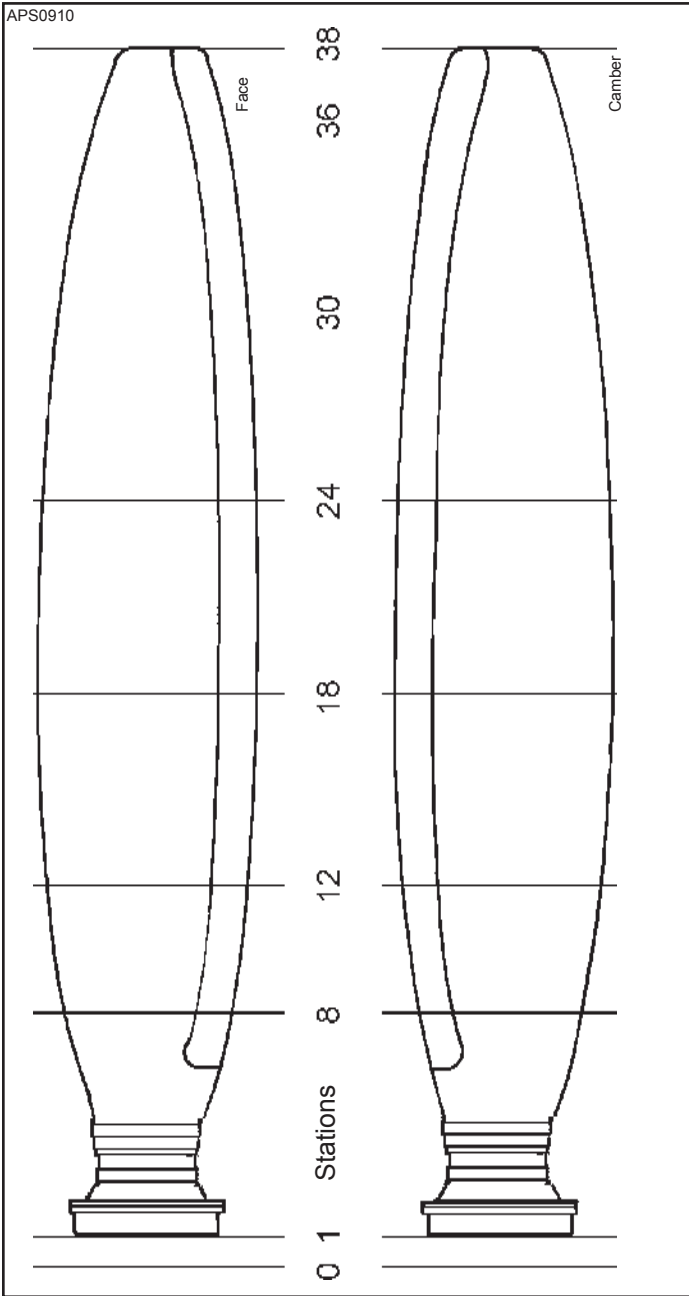

Record of B7421() Composite Blade Damage Repair

Blade Serial No. _____

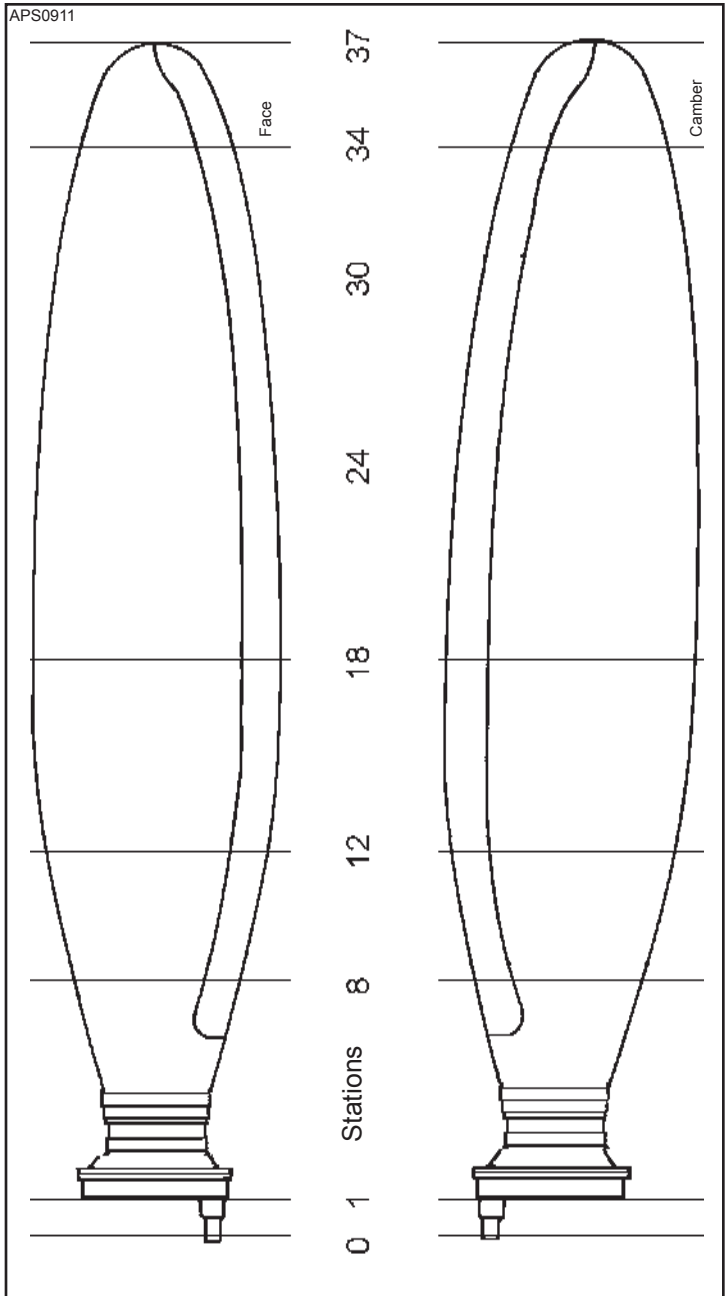

Record of B7421() Composite Blade Damage Repair

Blade Serial No. _____

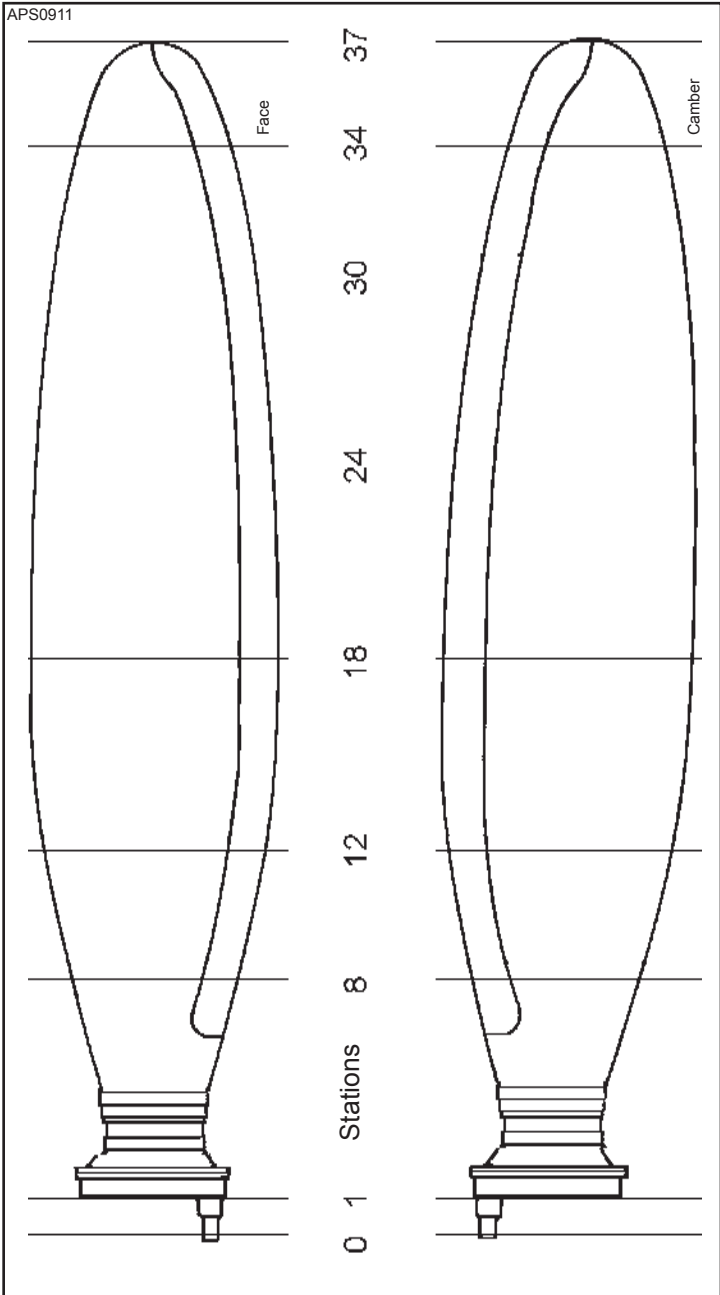

(This page is intentionally blank.)

Record of 7890() Composite Blade Damage Repair

Blade Serial No. _____

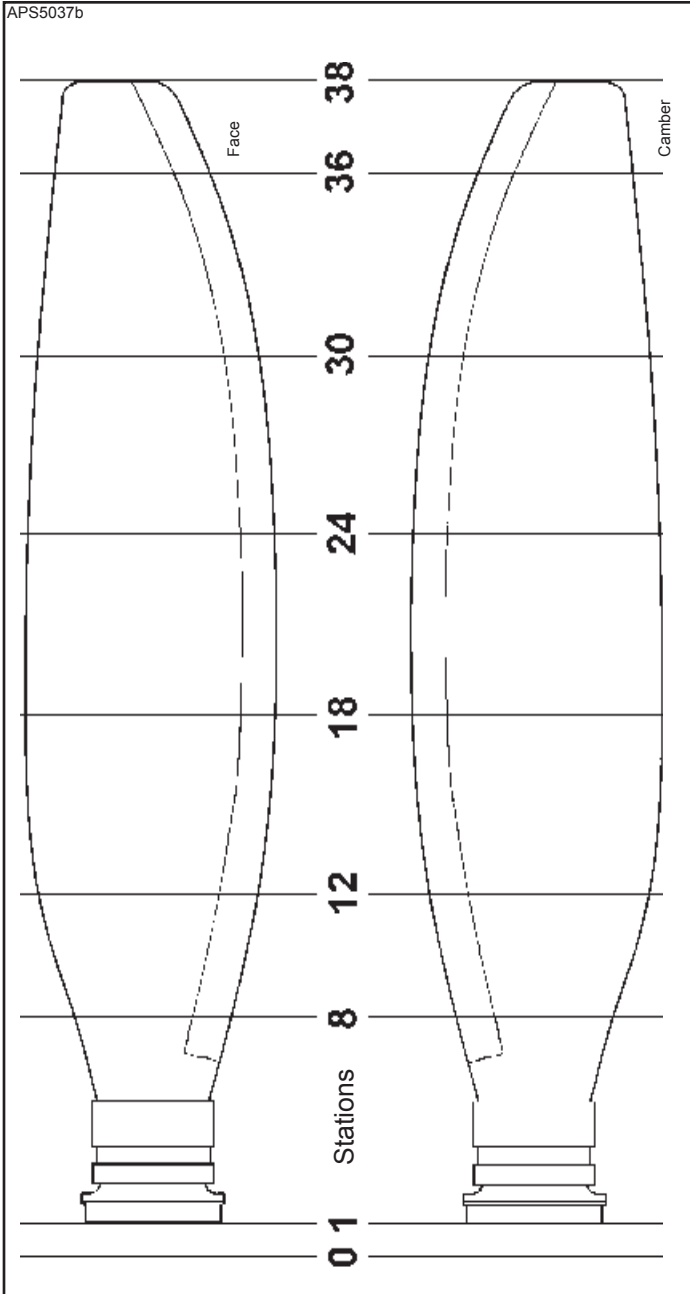

Record of 7890() Composite Blade Damage Repair

Blade Serial No. _____

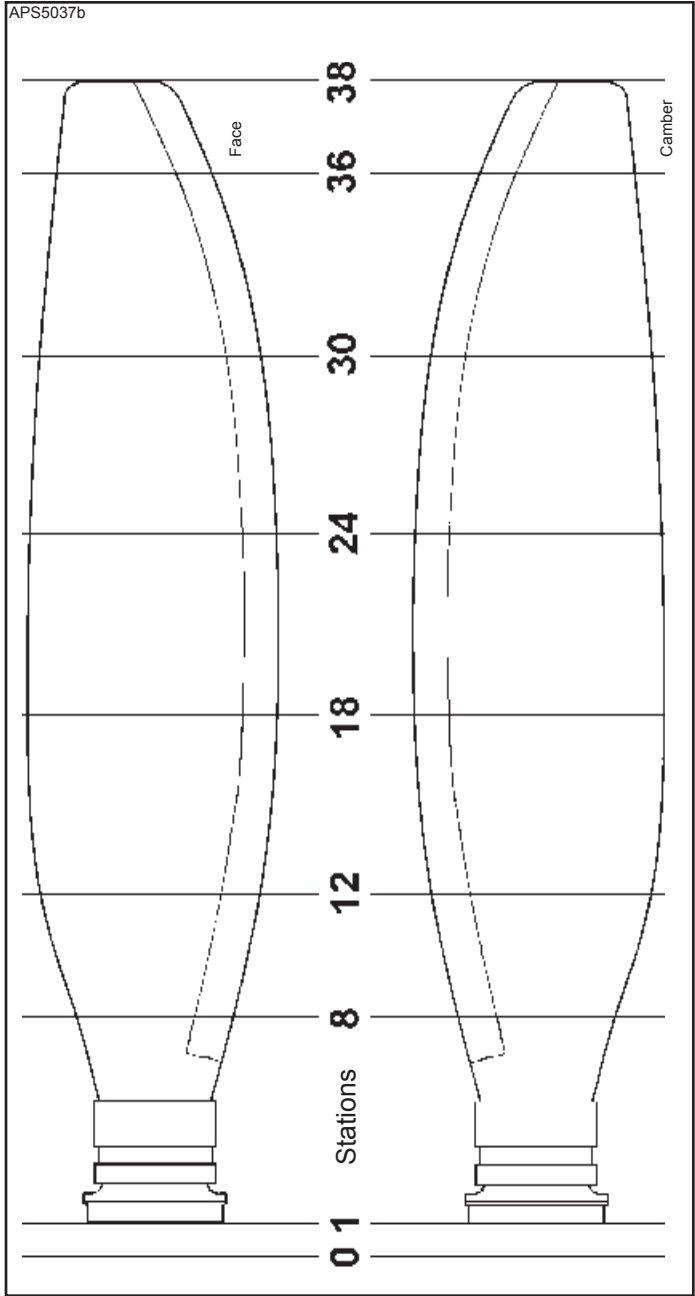

Record of 7890() Composite Blade Damage Repair

Blade Serial No. _____

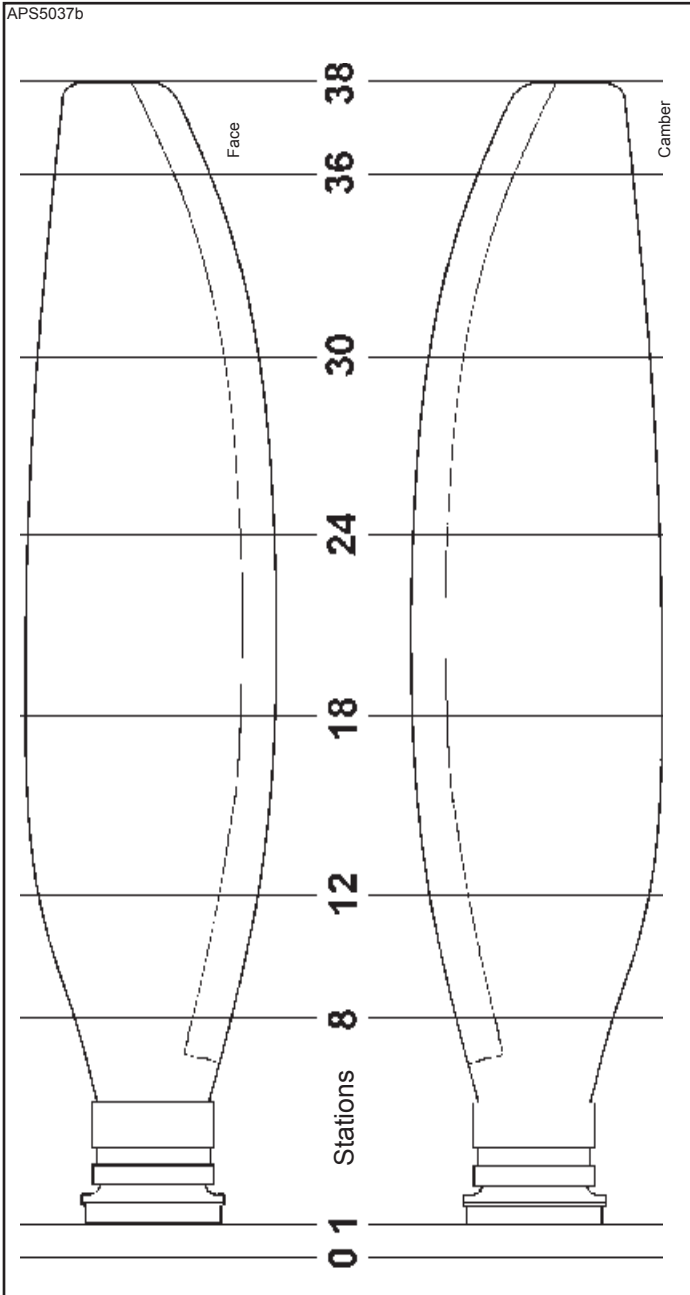

Record of () 7690() Composite Blade Damage Repair

Blade Serial No. _____

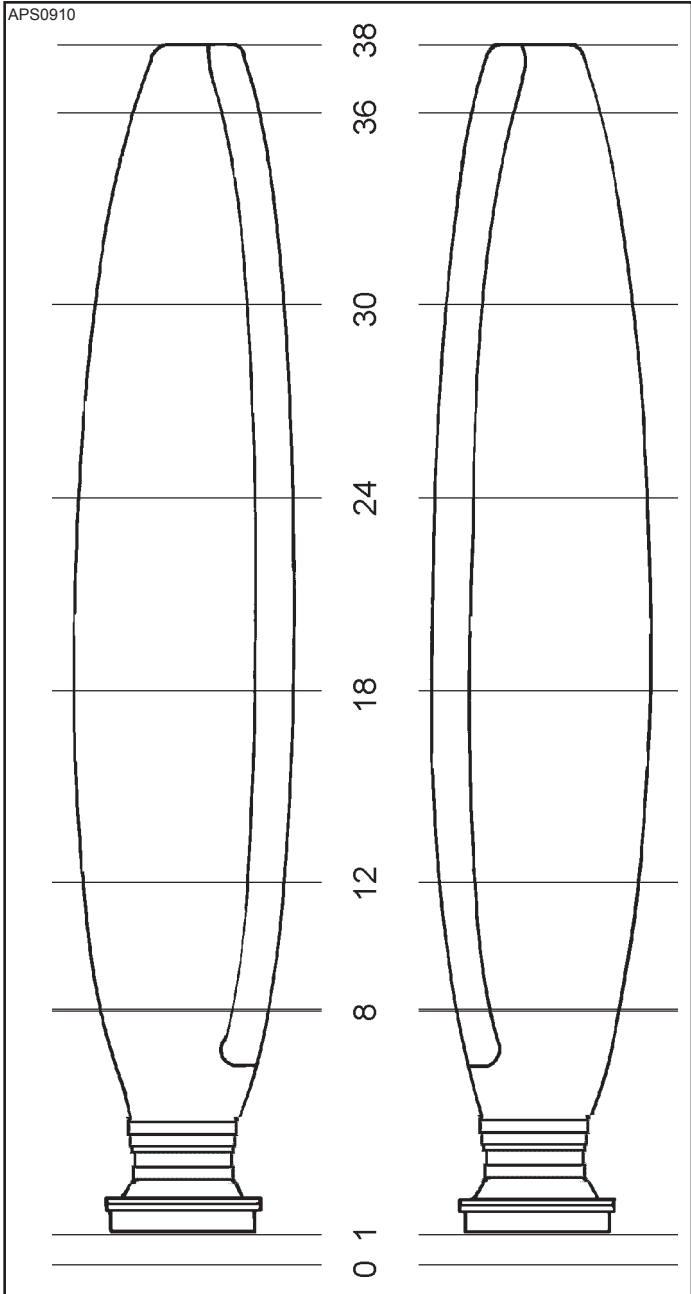

Record of () 7690() Composite Blade Damage Repair

Blade Serial No. _____

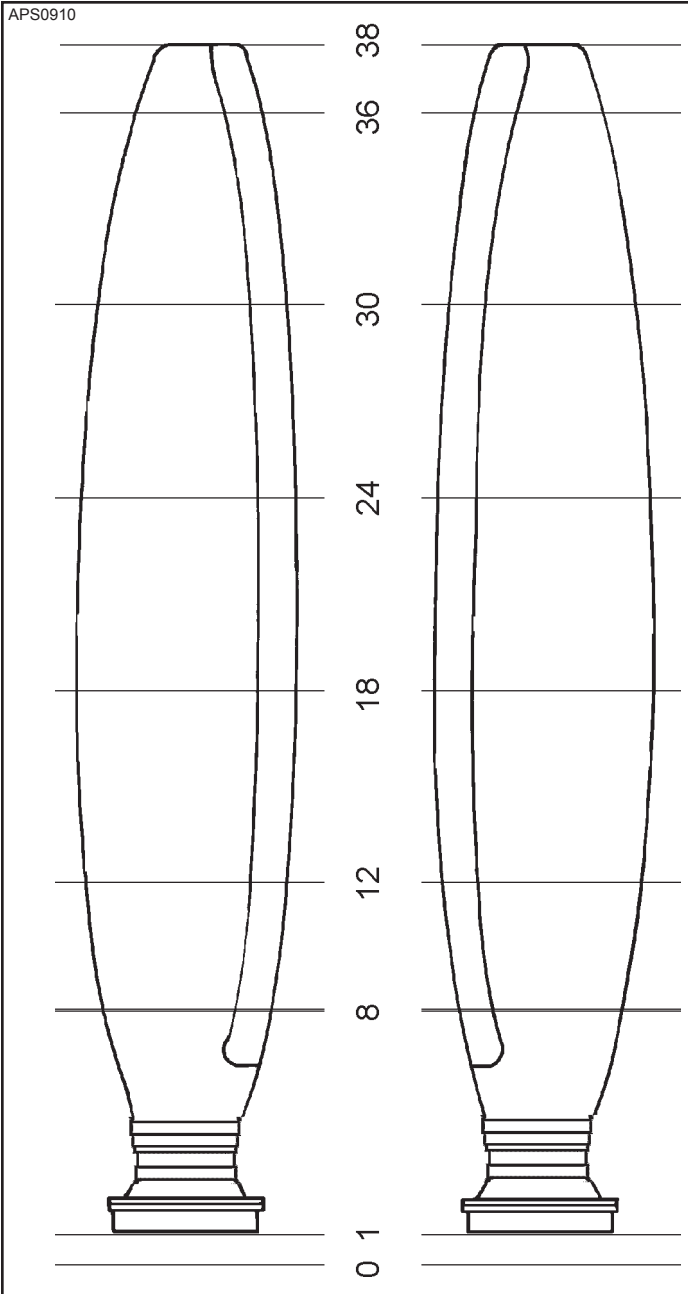

Record of () 7690() Composite Blade Damage Repair

Blade Serial No. _____

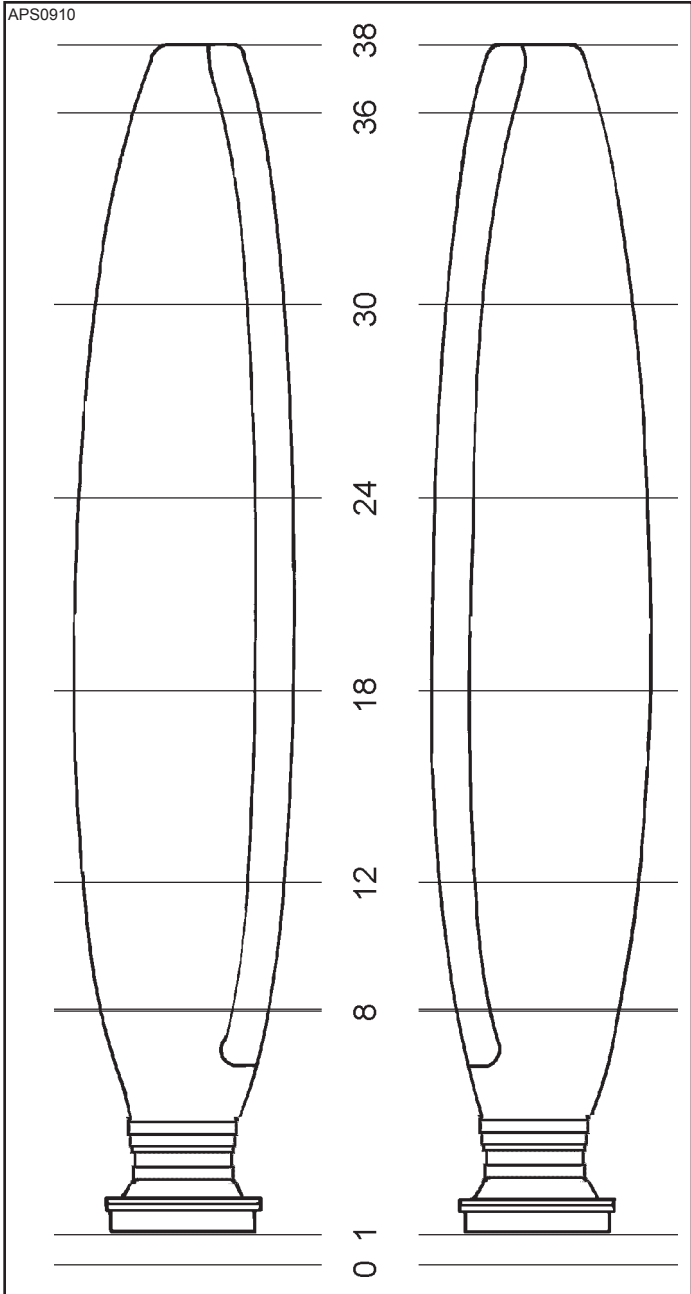

(This page is intentionally blank.)

Record of N()7893() Composite Blade Damage Repair

Blade Serial No. _____

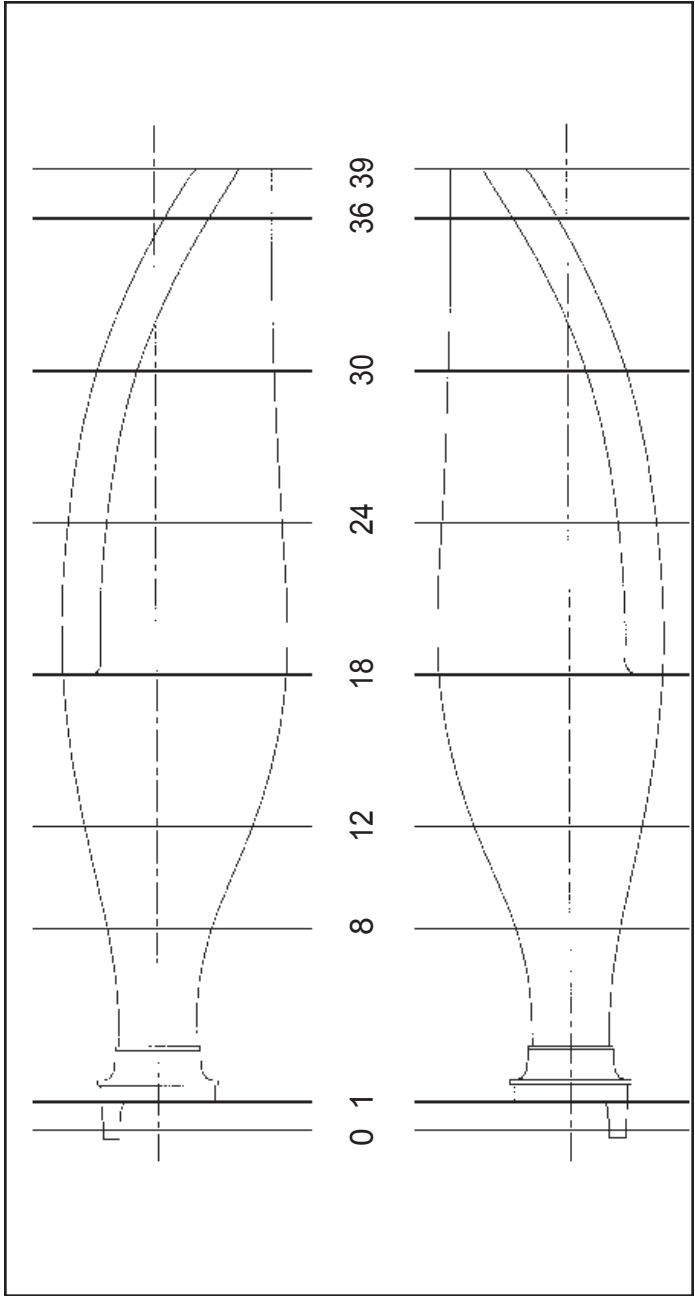

Record of N()7893() Composite Blade Damage Repair

Blade Serial No. _____

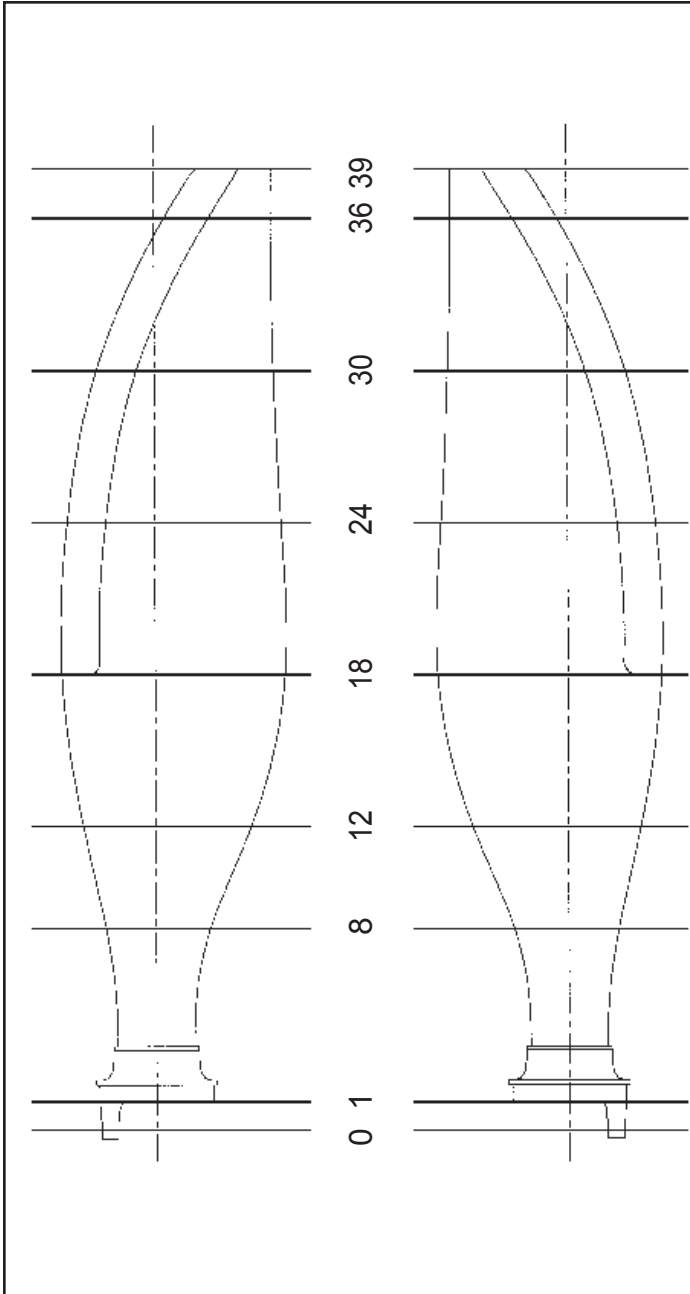

Record of N()7893() Composite Blade Damage Repair

Blade Serial No. _____

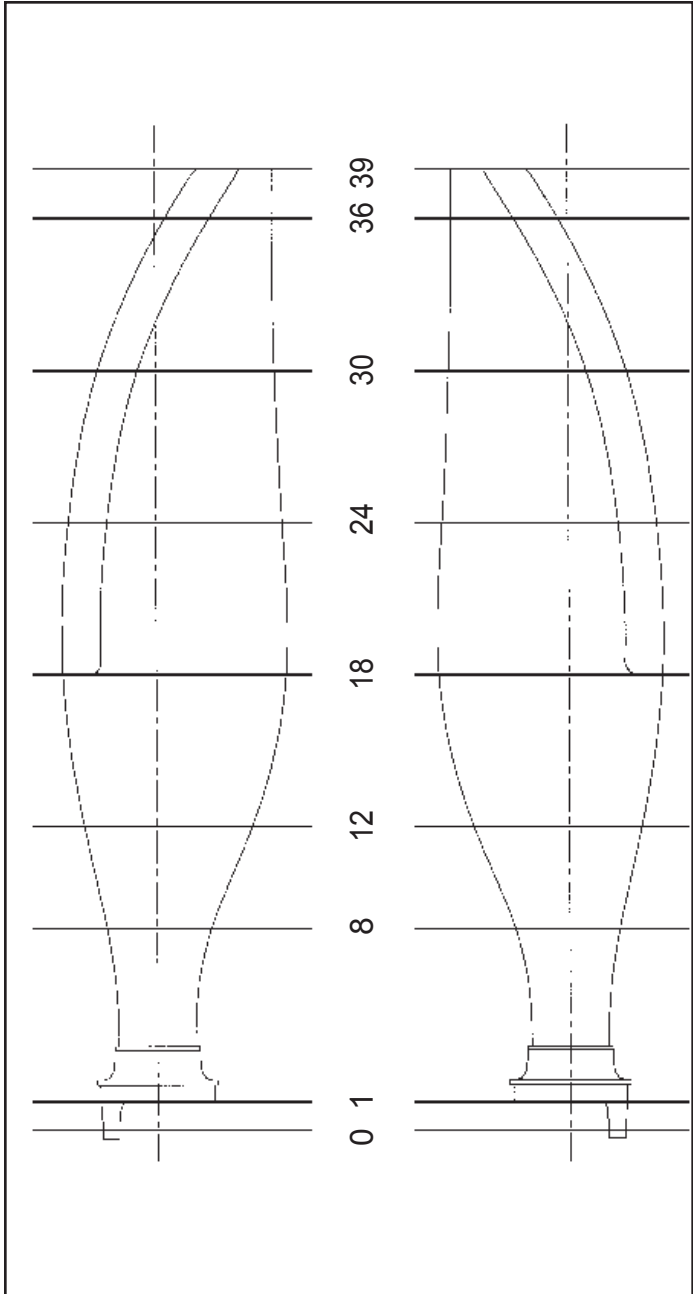

Record of N7605() Composite Blade Damage Repair

Blade Serial No. _____

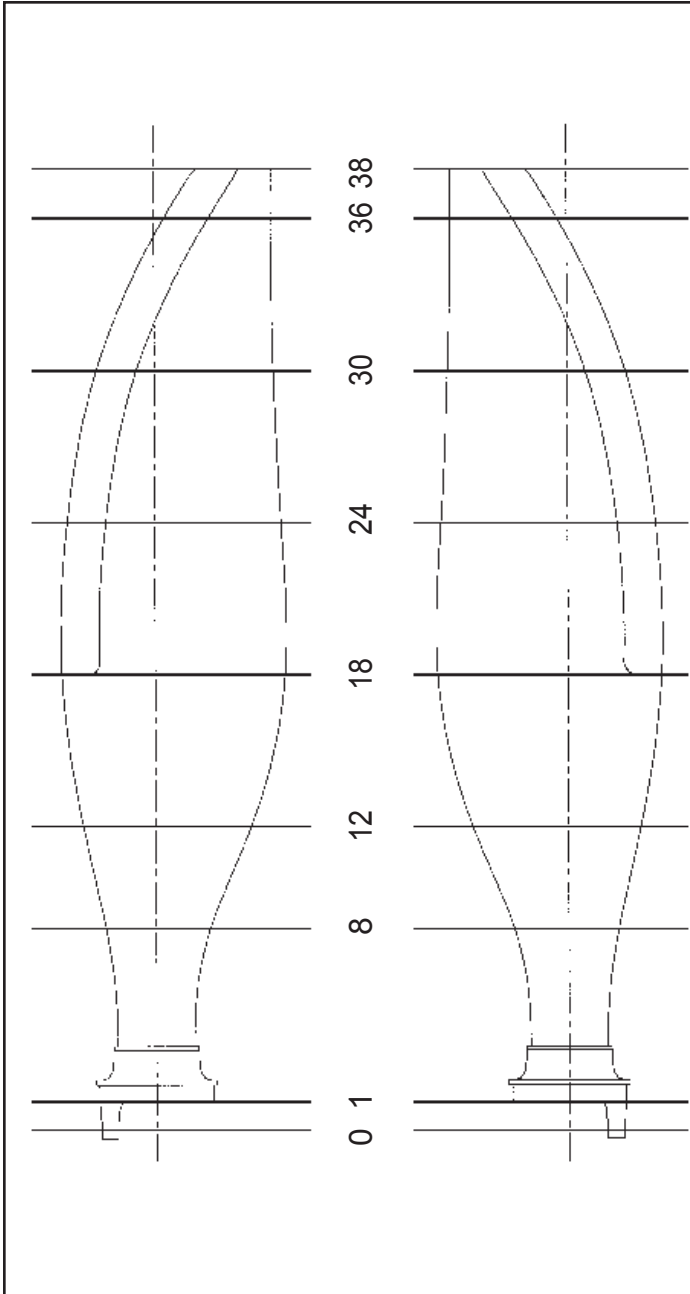

Record of N7605() Composite Blade Damage Repair

Blade Serial No. _____

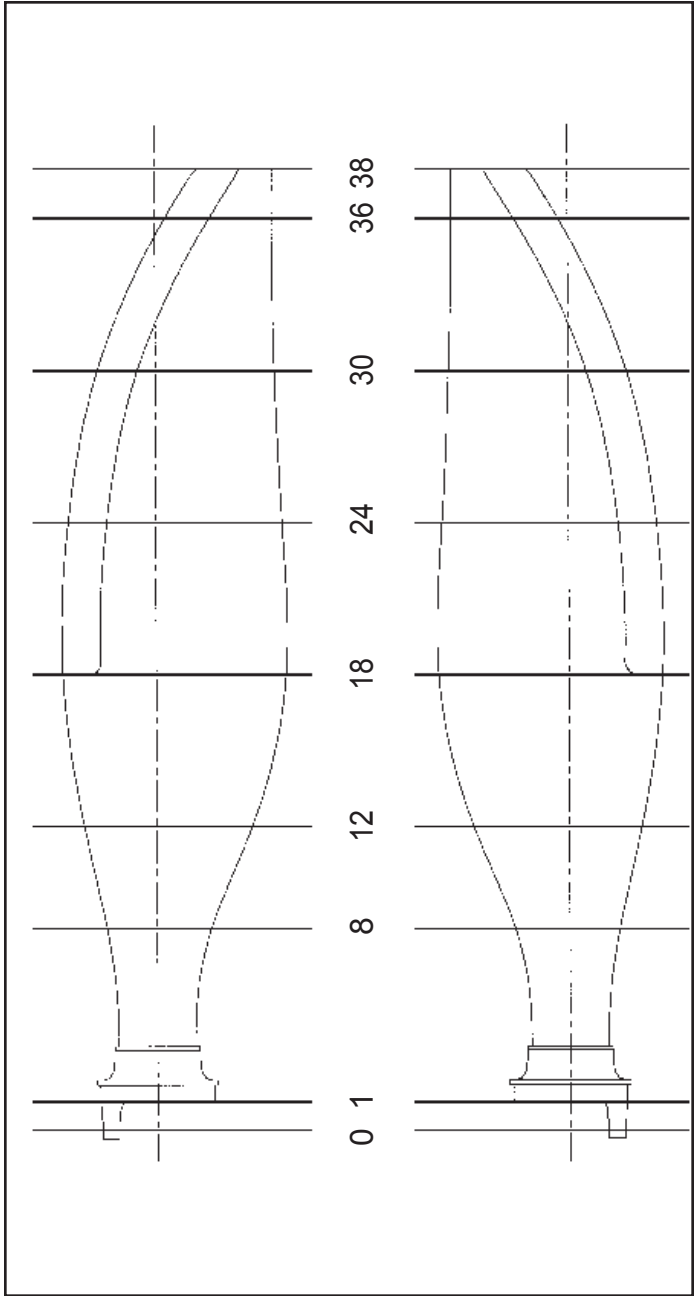

Record of N7605() Composite Blade Damage Repair

Blade Serial No. _____

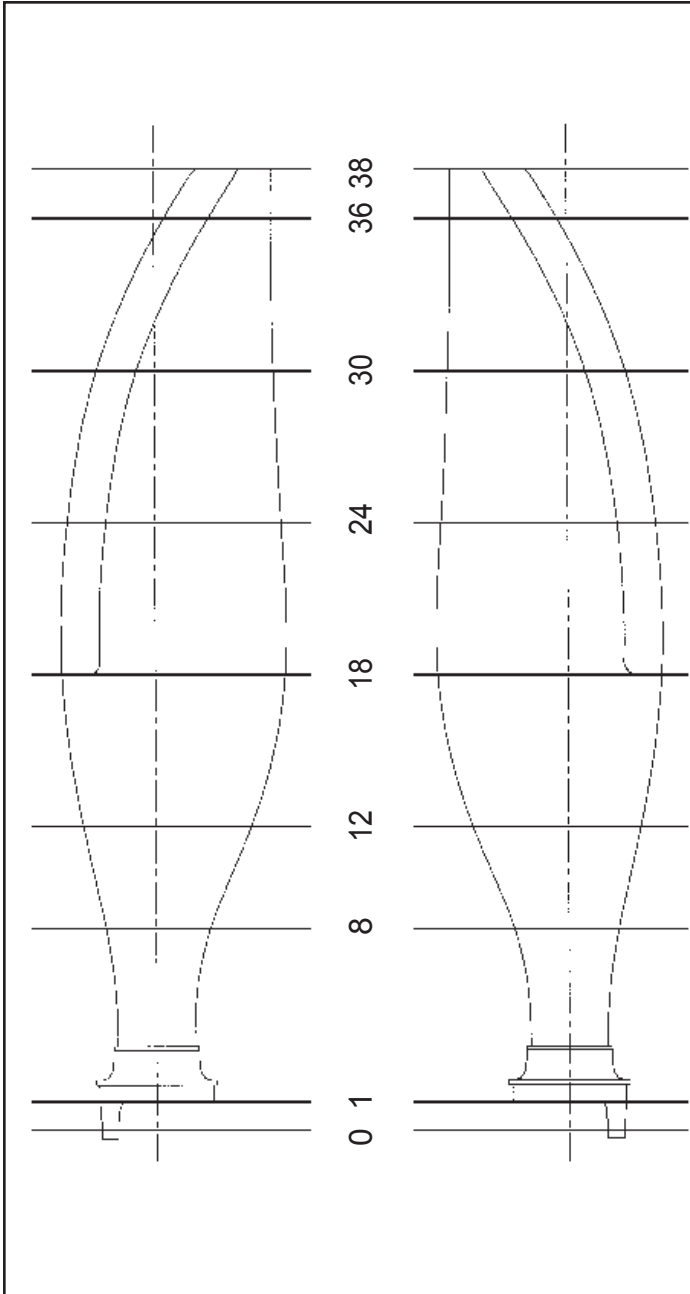

Record of N7605C() Composite Blade Damage Repair

Blade Serial No. _____

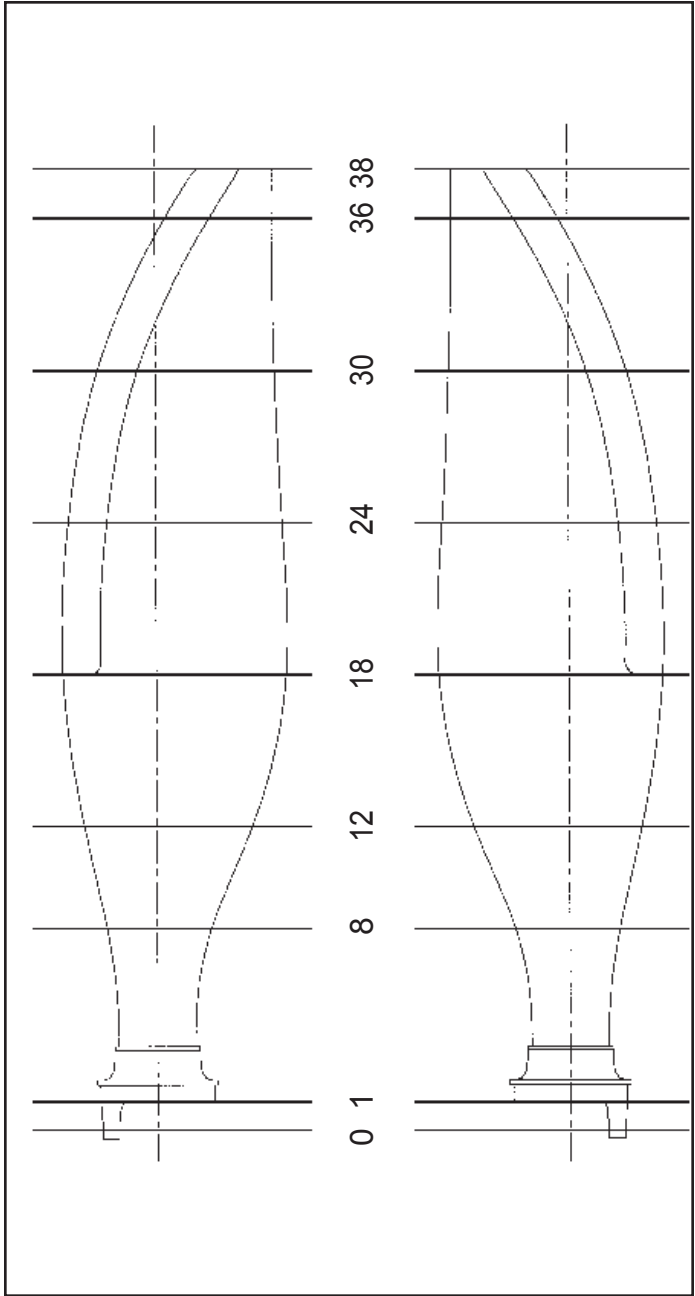

Record of N7605C() Composite Blade Damage Repair

Blade Serial No. _____

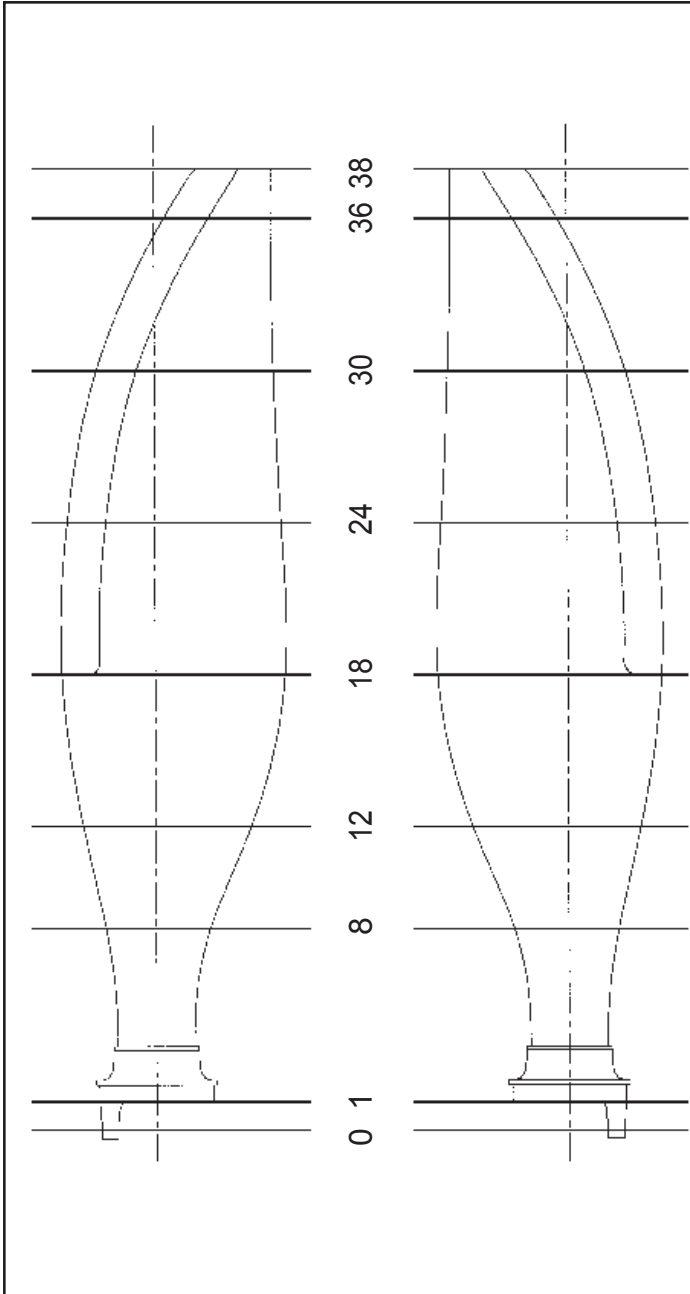

Record of N7605C() Composite Blade Damage Repair

Blade Serial No. _____

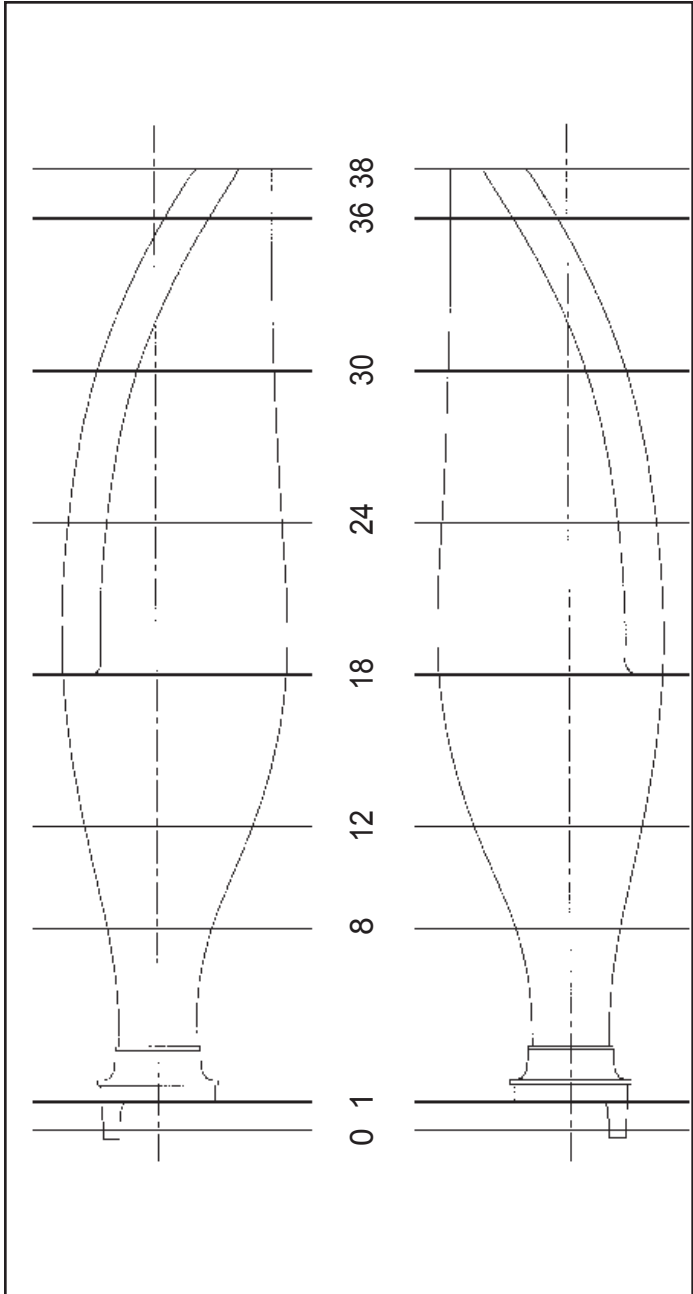

(This page is intentionally blank.)